

www.xcmg.com

QUY280履带起重机 QUY280 CRAWLER CRANE

本印刷品所包含的数据，会随着产品的不断升级而改变，请以实际产品为准
Pictures and data in this catalog will change with the update and modification of products, so please take the actual vehicle as reference.

徐工集团 工程机械股份有限公司建设机械分公司

XCMG, CONSTRUCTION MACHINERY CO., LTD. BUILDING MACHINERY CO.

地址：江苏省徐州市桃山路19号 邮编 (Post Code)：221002
Add: No.19 Taoshan Road, Xuzhou, Jiangsu Province, China
销售电话 (Sales Tel)：0516-87892099 0516-87892534 销售传真 (Sales Fax)：0516-87892015
服务/备件电话 (Service/Spare Parts Tel)：0516-87892088 0516-87892510
服务/备件传真 (Service/Spare Parts Fax)：0516-87892506
质量监督电话 (Quality Inquiry Tel)：0516-87892503

请垂询
CONTACT



QUY280履带起重机

QUY280 CRAWLER CRANE



 徐工集团 工程机械股份有限公司建设机械分公司

XCMG, CONSTRUCTION MACHINERY CO., LTD. BUILDING MACHINERY CO.

技术性能参数/整机基本尺寸 Technical Specification/Overall Dimension

主要零部件 Main Parts

目录 CONTENTS

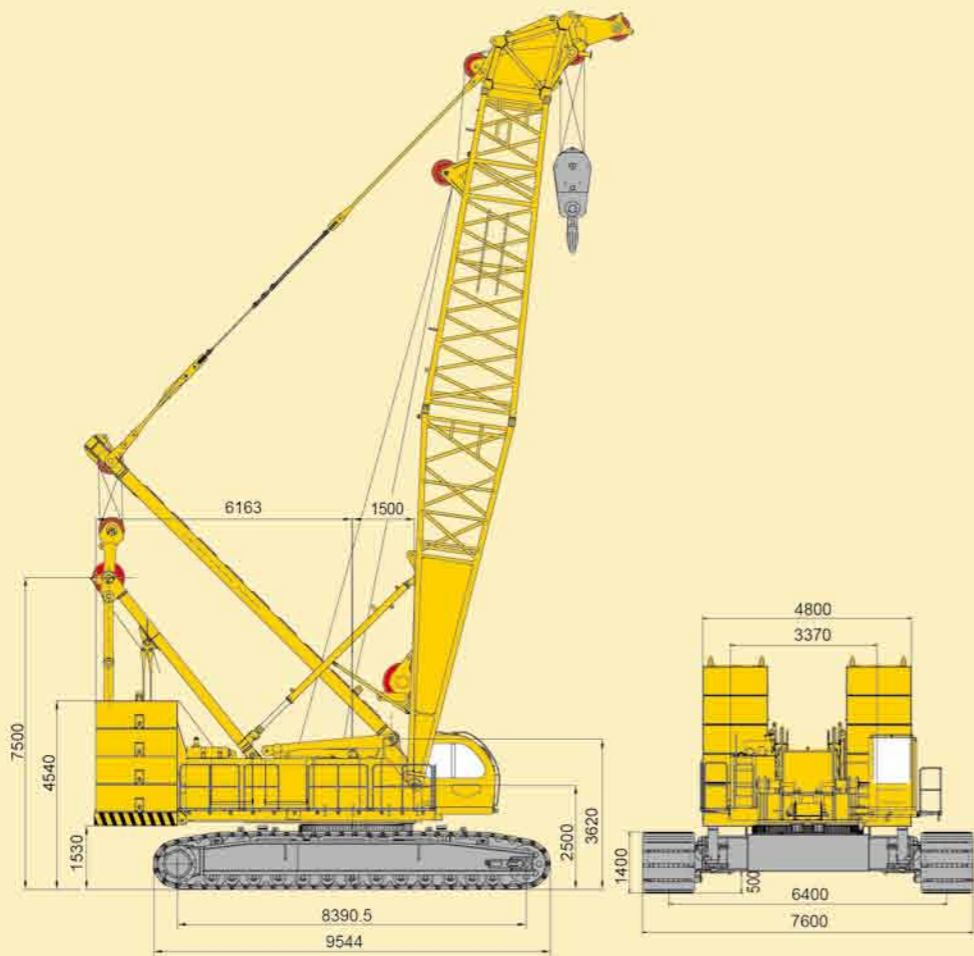

主要零部件 Main Parts	1
详细介绍 Brief Introduction	5
自拆装 Self Assembly & Disassembly	9
主臂臂节组合/主臂工况 Boom Combinations/Boom Working Condition	10
主臂作业范围 Boom Working Area	11
主臂工况载荷表 Boom Lifting Load Chart	12
固定副臂工况 Fixed Jib Working Condition	14
固定副臂作业范围 Fixed Jib Working Area	15
固定副臂工况载荷表 Fixed Jib Lifting Load Chart	16
塔式副臂工况 Tower Jib Working Condition	20
塔式副臂作业范围 Tower Jib Working Area	21
塔式副臂工况载荷表 Tower Jib Lifting Load Chart	24

项目 Items	单位 Unit	数值 Data
最大额定起重量 Max. lifting capacity	基本型主臂 Main boom	t 280
	固定副臂 Fixed jib	t 37
	塔式副臂 Tower jib	t 78
最大起重力矩 Max. load moment	kN·m	15000
臂架长度 Boom length	主臂长度 Main boom	m 18~87
	固定副臂长度 Fixed jib	m 12~36
	塔式副臂长度 Tower jib	m 27~60
主臂变幅角度 Boom luffing angle	(°)	30~82.6
起升机构最大单绳速度 (空载、第六层) Winch max. single line speed (no load, at 6th layer)	m/min	137
主臂变幅机构最大单绳速度 (第一层) Boom luffing gear max. single line speed (at 1st layer)	m/min	2×27
最大回转速度 Max. slewing speed	rpm	1.3
最高行驶速度 Max. travel speed	km/h	1.1
爬坡度 Grade ability	%	30
平均接地比压 Mean ground pressure	MPa	0.12
发动机功率 Engine output power	kW	242
整机质量(主吊钩、18米臂) Gross vehicle mass (main hook block, 18m boom)	t	252
运输状态单件最大质量 Max. weight of single unit in travel configuration	t	58.0
运输状态单件(主机)最大尺寸(长×宽×高) Max. dimension of single unit(basic machine) in travel configuration (L×W×H)	m	12.53×3.47×3.46





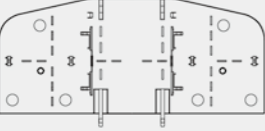
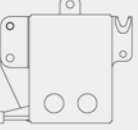

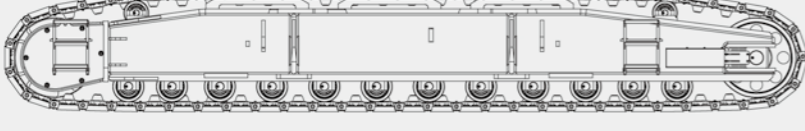
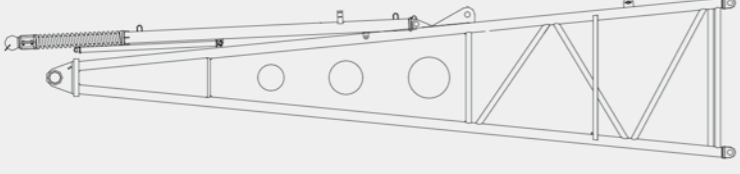
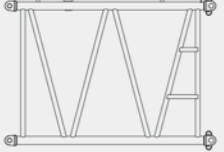
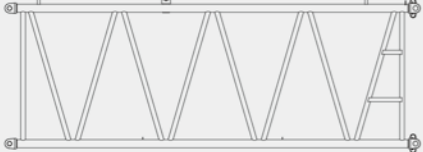



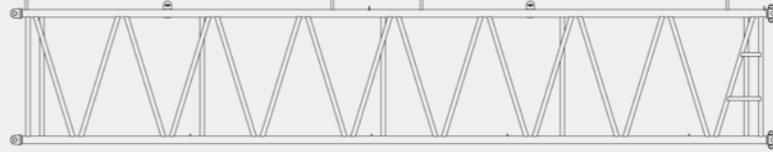
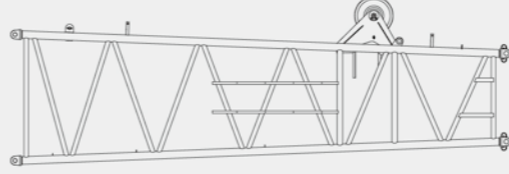
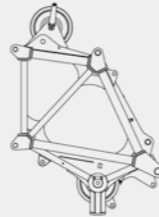

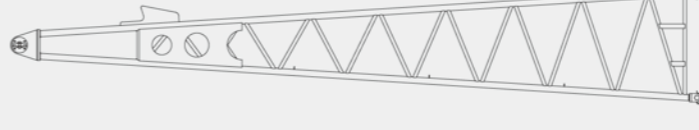
	主机 Basic machine	× 1
	长L	12530mm
	宽W	3470mm
	高H	3460mm
	重量 Weight	58000kg
	280t吊钩 Capacity Hook Block	× 1
	长L	2500mm
	宽W	1400mm
	高H	910mm
	重量 Weight	4500kg
	150t吊钩 Capacity Hook Block	× 1
	长L	2220mm
	宽W	900mm
	高H	850mm
	重量 Weight	2400kg
	80t吊钩 Capacity Hook Block	× 1
	长L	2030mm
	宽W	920mm
	高H	820mm
	重量 Weight	1400kg
	35t吊钩 Capacity Hook Block	× 1
	长L	1750mm
	宽W	900mm
	高H	390mm
	重量 Weight	1000kg
	12t吊钩 Capacity Hook Block	× 1
	长L	920mm
	宽W	520mm
	高H	520mm
	重量 Weight	600kg
	上车1(3)号配重 Upper Counterweight	× 5
	长L	1942.7mm
	宽W	1400mm
	高H	528mm
	重量 Weight	7000kg
	上车4(5)号配重 Upper Counterweight	× 1
	长L	1942.7mm
	宽W	1400mm
	高H	428mm
	重量 Weight	5000kg

主要零部件 Main Parts

	<p>上车2号配重 Upper Counterweight × 1</p> <p>长L 4576mm 宽W 1976mm 高H 640mm 重量 Weight 20000kg</p>
	<p>车身1号配重 Car-body counterweight × 2</p> <p>长L 1700mm 宽W 1030mm 高H 1010mm 重量 Weight 5000kg</p>
	<p>车身2号配重 Car-body counterweight × 2</p> <p>长L 2800mm 宽W 930mm 高H 1010mm 重量 Weight 10000kg</p>
	<p>履带架 Crawler × 2</p> <p>长L 9510mm 宽W 1380mm 高H 1400mm 重量 Weight 27000kg</p>
	<p>主臂底节臂 Boom Butt × 1</p> <p>长L 9280mm 宽W 2460mm 高H 2357mm 重量 Weight 5700kg</p>
	<p>主臂3米节 Boom Insert × 1</p> <p>长L 3160mm 宽W 2460mm 高H 2492mm 重量 Weight 1150kg</p>
	<p>主臂6米节 Boom Insert × 1</p> <p>长L 6160mm 宽W 2460mm 高H 2492mm 重量 Weight 2000kg</p>

主要零部件 Main Parts

	<p>主臂12米节 Boom Insert × 5</p> <p>长L 12160mm 宽W 2460mm 高H 2492mm 重量 Weight 3600kg</p>
	<p>主臂7.8米节 Boom Insert × 1</p> <p>长L 7960mm 宽W 2460mm 高H 2836mm 重量 Weight 2800kg</p>
	<p>主臂臂头 Boom Head × 1</p> <p>长L 2251mm 宽W 1970mm 高H 3061mm 重量 Weight 3200kg</p>
	<p>主臂臂端单滑轮 Boom Head Single Sheave × 1</p> <p>长L 1400mm 宽W 576mm 高H 980mm 重量 Weight 330kg</p>
	<p>塔臂底节臂 Tower Jib Butt × 1</p> <p>长L 9211mm 宽W 1920mm 高H 1620mm 重量 Weight 1250kg</p>
	<p>塔臂3米节 Tower Jib Insert × 2</p> <p>长L 3120mm 宽W 1920mm 高H 1620mm 重量 Weight 420kg</p>
	<p>塔臂6米节 Tower Jib Insert × 2</p> <p>长L 6120mm 宽W 1920mm 高H 1620mm 重量 Weight 650kg</p>

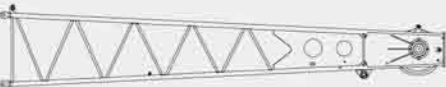
	塔臂12米节 Tower Jib Insert × 2
	长L 12120mm
	宽W 1920mm
	高H 1620mm
	重量 Weight 1130kg
	塔臂顶节臂 Tower Jib Top × 1
	长L 9562mm
	宽W 1920mm
	高H 1620mm
	重量 Weight 2600kg
	塔臂前支架 Tower Jib Front Strut × 1
	长L 9965mm
	宽W 1495mm
	高H 835mm
	重量 Weight 2150kg
	塔臂后支架 Tower Jib Rear Strut × 1
	长L 8960mm
	宽W 1795mm
	高H 1085mm
	重量 Weight 2200kg
	固定副臂底节臂 Fixed Jib butt × 1
	长L 6230mm
	宽W 1950mm
	高H 1258mm
	重量 Weight 700kg
	固定副臂中间节 Fixed Jib Insert × 4
	长L 6100mm
	宽W 1282mm
	高H 1258mm
	重量 Weight 600kg
	固定副臂顶节臂 Fixed Jib Top × 1
	长L 6430mm
	宽W 1282mm
	高H 1258mm
	重量 Weight 1000kg

说明 Notes

- 以上零部件运输形状为示意图，所标尺寸为设计值，不包括包装。
The above parts dimension is only for illustration, the dimension shown is design value, and does not include the package.
- 重量为设计值，由于制造误差，可能稍有不同。
The weight is design value, may have slight difference due to error in manufacture.

上车

发动机

采用康明斯QSL9-C325电喷发动机，额定功率242kW，额定转速为2100rpm，最大输出扭矩1424N·m。符合欧洲工程机械第三阶段排放标准。

控制

智能化计算机集成式可编程控制系统，是该产品的关键核心技术，采用PLC可编程控制器，与常规电气相结合，完成系统的逻辑控制与电比例控制功能，实现起重机的自动控制，大大提高起重机的作业安全性、可靠性和作业效率。本机的操作可以通过电脑的大屏幕显示出来，很方便的实现了人机对话。

液压系统

采用电比例控制，开闭式回路相结合，恒功率变量泵系统。
液压系统组成：起升系统，变幅系统，回转系统，塔臂防后倾系统，行走系统，辅助安装系统。
特点：起升系统、变幅系统、行走系统采用开式系统，主泵为恒功率变量泵，液压先导控制变量；具有功率限制，压力切断功能，可以满足多个执行元件动作要求。回转系统采用闭式系统，响应快，控制精准，起制动、换向平稳，无冲击。可以满足频繁换向，微动操作。

起升机构

主、副起升型号相同，单独驱动，双泵合流供油；片式常闭制动器，力士乐内藏式减速机。主、副起升机构与转台采用销轴连接，便于组装。驱动马达、平衡阀、起升钢丝绳均为德国进口。最大速度可达120m/min，具有优良的微速性能，起升机构还具有换油方便、低噪音、高效率、长寿命等特性。

变幅机构

主臂变幅为一个双联卷筒独立驱动，使用塔臂工况时，利用副起升机构作为塔臂变幅机构使用。主臂变幅机构采用内藏式减速机（力士乐），片式常闭制动器。卷筒设有棘轮锁止装置，以实现机械制动，安全可靠。主臂变幅机构与转台采用螺栓连接，便于组装。驱动马达、平衡阀、变幅钢丝绳均为德国进口。

回转机构

回转机构布置在转台内侧前面，由两个行星减速机（力士乐）组成，与回转支承外啮合。液压缓冲，具有自由滑转功能。行星齿轮减速机，可控常闭、片式制动器，工作可靠，维修方便。

回转支承

采用罗特艾德的三排滚柱式回转支承，质量稳定可靠。

上车配重

上车1号配重：35t：5×7t，共5块；
上车2号配重：20t：1×20t，共1块；
上车3号配重：35t：5×7t，共5块；
上车4号配重：5t：1×5t，共1块；
上车5号配重：5t：1×5t，共1块；

Crane Superstructure

Engine

Cummins QSL9-C325 diesel engine with electronic injection, rated output power 242kW, rated speed 2100rpm, max. output torque 1424N.m, emission in compliance with European Construction Machinery Stage III.

Control System

Intelligent computer integrated program control system is the key technology of the crane. PLC program controller is used, with combination of conventional electrics, to realize the function of logic control and electronic proportional control of the system, greatly improving safety, reliability and efficiency for crane operation. Crane operation can be shown by a larger screen computer display, and easy for man-machine interaction.

Hydraulic System

Electronic proportional control, with combination of close/open type circuit, constant power and variable displacement pump system.
Hydraulic system: winch, luffing gear, slewing gear, tower jib backstop, travel gear, auxiliary assembly system.
Features: winch, luffing gear, travel gear are of open type system, main pump is constant power and variable displacement pump, variable displacement by hydraulic pilot control, with function of power limit and pressure cut-off, may satisfy the requirement of multiple actuator movement. Slewing gear is close type system, quick response, accurate control, stable starting, braking and direction change, no impact, may satisfy operation of frequent direction change and fine motion control.

Winch

Main/auxiliary winch has same model, with independent drive and combination of two pumps for oil supply; disc type constant closed brake, Rexroth built-in speed reducer; main/auxiliary winch and turntable connected by pin shaft, easy for assembly. Drive motor, counterbalance valve, winch wire rope imported from Germany, max. line speed 120m/min., with good fine speed performance. Winch also features easy oil replacement, low noise, high efficiency and long service life.

Luffing Gear

Boom luffing gear is a twin drum independent drive unit, and use auxiliary winch as tower jib luffing gear when tower jib is in use. Main/auxiliary winch has built-in speed reducer (Rexroth), and disc type constant closed brake. Winch drum has a ratchet locking device to realize mechanical braking, safe and reliable. Boom luffing gear and turntable connected by pin shaft, easy for assembly. Drive motor, counterbalance valve, winch wire rope are all imported from Germany.

Slewing Gear

Slewing gear is arranged inside the front of turntable, made up by two planetary reducers (Rexroth), and external meshed with slewing ring, hydraulic buffering, and with the function of free swing. Planetary reducer has a controllable constant-closed disc brake, reliable working and easy for maintenance.

Slewing Ring

Slewing ring is a 3-row roller type slewing bearing made by Xuzhou Rothe Erde, with reliable quality.

Upper Counterweight

Upper counterweight 1: 40t 5×8t total 5 slabs;
Upper counterweight 2: 20t 1×20t total 1 slab;
Upper counterweight 3: 40t 5×8t total 5 slabs;
Upper counterweight 4: 5t 1×5t total 1 slabs;
Upper counterweight 5: 5t 1×5t total 1 slabs;

详细介绍

Brief Introduction

操纵室

操纵室采用钢制框架结构，正面配置有整体式夹层玻璃，其余玻璃均为钢化玻璃。装有可调式座椅、按人机工程学布置的全套操纵仪表和控制装置，配置风道式冷暖空调、音响、灭火装置、闭路监视系统等，宽敞舒适。工作时，操纵室可调整俯仰角度，扩大视野，方便操作；运输时，操纵室可从侧方转到前方，减小运输宽度。

转台

转台采用箱型与单腹板混合的结构，该结构整体稳定性好。转台是联系上下车的关键承载结构件。转台通过回转支承与下车进行联接。驾驶室、起升机构、变幅机构、发动机、人字架、桅杆、臂架及配重等分别与转台在不同部位进行联接。

下车

车架

车架采用高强度钢板、箱形结构，中间设置横隔板，加强其抗扭刚度，结构简单，承载能力强，刚性好。

履带架

包括履带梁和四轮一带。履带梁采用箱形结构，和车架连接部位局部加强，中间设置横隔板。两个履带架对称布置，装有宽度为1.2m的履带板。

行走机构

履带行走驱动采用德国进口的内藏式行星齿轮减速机，液压释放行走制动器，每个减速机由德国进口的轴向柱塞变量马达驱动，可同步操作，也可单独操纵，以实现直行和转弯。

行走速度

变量马达可以实现无级变速，最高速度1公里/小时。行走时，设备运行平稳，可实现快速行走。

车身配重

车身1号配重：10t：2×5t，共2块；
车身2号配重：20t：2×10t，共2块

作业装置

起重臂包括主臂、固定副臂和塔式副臂。结构型式为中间等截面，两端变截面的四弦杆空间桁架结构，主弦杆采用进口高强度管材，腹杆采用国产优质管材，提高了臂架抗弯曲的能力。

主臂

主臂为中间等截面、两端变截面的空间桁架式结构，钢管焊接，臂架顶部与根部用钢板加强，以利于传递载荷。主臂配置臂端单滑轮机构，主臂长度为18~87m。
组成：底节臂9m、中间节臂3m×1、中间节臂6m×1、中间节臂12m×5、顶节臂7.8m×1，臂头1.2m×1。

Operator's Cabin

Operator's cabin is steel frame structure, front windshield has overall type safety glass, other glass is hardened glass, equipped with adjustable seat, all kinds of ergonomic designed instruments and controls, vent type air-conditioner, CD player, fire extinguisher, and closed circuit monitoring system, spacious and comfortable. When the crane is in operation, the operator's cabin can be tilted upward to widen the field of vision. When the crane is in transportation, the operator's cabin can be turned from the side to the front so as to reduce the transport width.

Turntable

Turntable is structure of box type and single web plate, with good overall stability. Turntable is key structural part linked with crane superstructure and crane carrier for load bearing, with many mechanisms arranged on it, such as operator's cabin, winch, luffing gear, engine, gantry, mast, boom and counterweight.

Crane Carrier

Car-body

Car-body is made of high strength steel, box-type structure, with cross panel installed in the middle to strengthen its stiffness of torsion resistance, simple structure, high loading capacity and well rigidity.

Crawler Track

Crawler track consists of track beam, drive sprocket, idler wheel, upper roller, lower roller and track. Crawler beam is box-type structure, the connection place to frame is strengthened partially, and cross panel is installed in the middle of it. Two crawler tracks are symmetrically arranged.

Travel Gear

Travel gear drive has German imported built-in planetary gear reducer and hydraulic release service brake, each reducer is driven by German imported axial piston variable displacement motor, can be operated synchronously or independently to realize straight travel and turning around.

Travel Speed

Variable displacement motor can realize infinitely variable drive, max. speed 1 km/h, stable and fast travel.

Car-body counterweight

Car-body counterweight: 10t 2×5t total 2 slabs;
Car-body counterweight: 20t 2×10t total 2 slabs.

Lifting Operation Parts

Lifting boom comprises main boom, tower jib and special jib, the structural type is lattice structure of four tubular chords with intermediate equal section and two end variable section; the main boom chord is made of imported high quality tube, and web rod is made of domestic high quality tube, with the ability for improving torsion resistance.

Boom

Main boom is lattice structure of intermediate equal section and two end variable section, welded by steel tube, boom top and boom foot reinforced by steel plate for load transfer, and equipped with boom head single sheave, boom length: 18m~87m.
Construction: 9m boom butt, 3m×1 boom insert, 6m×1 boom insert, 12m×5 boom insert, 7.8m×1 taper extension, 1.2m×1 boom head.

详细介绍

Brief Introduction

固定副臂

固定副臂为中间等截面、两端变截面的空间桁架式结构，钢管焊接，臂架顶部与根部用钢板加强，以利于传递载荷。
固定副臂可在主臂长45~75米范围内进行作业，其作业长度为12~36m，含10°及30°两种安装角。
组成：底节臂6m、中间节臂6m×4、顶节臂6m。

塔式副臂

塔式副臂为中间等截面、两端变截面的空间桁架式结构，钢管焊接，臂架顶部与根部用钢板加强，以利于传递载荷。
塔式副臂可在主臂长30~60米范围内进行作业，其作业长度为27~60m。
组成：底节臂9m、中间节臂3m×2、中间节臂6m×2、中间节臂12m×2、顶节臂9m。

桅杆

桅杆结构为箱形双臂结构,该结构整体稳定性好。在自拆装时，可组成桅杆吊，用于拆装整机的大型结构件。

人字架

人字架是重要结构件之一，前足采用箱形双臂结构，后足采用可折叠式拉板，前足装有油缸，用于起落人字架和自拆装转台配重。

吊钩

标准配置：280t吊钩、150t吊钩、80t吊钩、35t吊钩、12t吊钩

安全装置

安全装置包括力矩限制器、转台回转锁销装置、起重臂防后翻装置、起升高度限位装置、风速仪、水平仪、液压系统的溢流阀、平衡阀、双向液压锁、回转警告、行走警告等。

应急功能

系统程序崩溃时，可采用控制柜中的翘板开关把整机操作到安全状态。此时所有安全保护功能不起作用。

力矩限制器

检测功能：力矩限制器能自动检测出起重臂的角度、起重载荷，
显示功能：实时的显示当前实际载荷，工作半径，起重臂角度和当前风速。
警告功能：如果检测到实际载荷超过额定载荷，起重臂超过极限角度，力矩限制器发出报警并限制当前动作。

主、副提升过卷装置

当主、副卷扬上升到一定高度时，仪表板上的过卷保护指示灯亮，同时力矩限制器停止起升动作。

Fixed Jib

Fixed jib is lattice structure of intermediate equal section and two end variable section, welded by steel tube, jib top and jib foot reinforced by steel plate for load transfer.
Fixed jib can be operated within the range of boom length 45~75m, and lifting operation length is 12~36m, with two offset angle of 10° and 30°.
Construction: 6m jib butt, 6m×4 jib insert, 6m jib top.

Tower Jib

Tower jib is lattice structure of intermediate equal section and two end variable section, welded by steel tube, jib top and jib foot reinforced by steel plate for load transfer.
Tower jib can be operated within the range of boom length 30~60m, and lifting operation length is 27~60m.
Construction: 9m jib butt, 3m×2 jib insert, 6m×2 jib insert, 12m×2 jib insert, 9m jib top.

Mast

The mast is box-type structure of twin tubular chord, with good overall stability. When carrying out crane assembly/disassembly, the mast can be combined with other lifting parts for mounting and dismounting large crane structural parts.

Gantry

Gantry is one of the important structural parts, the front foot is box-type structure of twin tubular chord, with hydraulic cylinder for raising and lowering gantry, and for turntable and counterweight self assembly/disassembly; and the rear foot is folded pendant.

Hook Block

Standard equipment: 280t capacity hook block, 150t capacity hook block, 80t capacity hook block, 35t capacity hook block, 12t capacity hook block.

Safety Devices

Safety devices comprise: load moment limiter, turntable lock pin, boom backstop, hoist limit switch, anemometer, level gauge, hydraulic overflow valve, counterbalance valve, two-way hydraulic lock, slewing warning lamp and travel warning lamp, etc.

Emergency Function

When a breakdown occurs in the system, a toggle switch on control panel may be used to control the whole machine into safe state, at this time all safe protections have no use.

Load Moment Limiter

Detection function: automatically detect boom angle and lifting load.
Display function: real time display current actual load, working radius and boom angle.
Warning function: automatically send out warning and stop crane operation when detecting actual load exceed total rated load and boom out of limit angle.

Main/Auxiliary Winch Over-Wound Protection Device

When main/auxiliary winch hoists up to a certain lifting height, an over-wound warning lamp on instrument panel lights on, at the same time, load moment limiter stops crane hoisting up operation.

详细介绍 Brief Introduction

主、副提升过放装置

此保护功能由安装在卷筒内部接近开关检测到卷筒上的钢丝绳剩下三卷时，仪表盘上的指示灯亮，同时力矩限制器自动停止起升落动作。

安全保护开关

该安全保护开关放在手柄前侧，此开关没有按下的时候，所有动作信号被屏蔽，手柄不起作用。防止身体碰撞手柄产生误操作。

棘爪锁止装置

用于锁定变幅卷扬，起重臂降落的时候必须打开该装置，否则不能降落，用于保护臂架在非工作时安全停放。

起重臂角度限制

主起重臂仰角在82.8°时，起重臂被停止起升，由力矩限制器和行程开关双级控制。主起重臂在仰角小于30°时停止起重臂降落，由力矩限制器控制并发出声音报警。塔臂由行程开关和力矩限制器双级控制上限位和下限位。

监控系统

由2个摄像头和一个监视器组成，分别监视主、副卷扬和变幅卷扬

声光报警器

在履带起重机移动或做回转动作的时候灯闪烁并且发出声音报警。

力限器三色报警灯

由三种颜色组成，负载在90%以下时“绿灯”亮，表示起重机在安全区域运行，负载在90%-100%的时候“黄灯”亮，表示起重机在已接近额定载荷范围，负载在100%-105%以上时“红灯”和“黄灯”同时亮，表示起重机已经超载，在危险区域，控制系统自动切断起重机向危险的方向运行。

照明灯

装置在转台前方、臂架上和操纵室内，用于夜间工作时提供照明。

示高灯

安装在臂架顶部，作为高空警示。

风速仪

实时检测当前风速，传送到操纵室的监视器上，提醒司机操作的安全性。

Main/Auxiliary Winch Over-Release Protection Device

When access switch in winch drum detects only three turns of wire rope left on the drum, an over-release warning lamp on instrument panel lights on, at the same time, load moment limiter stops crane hoisting up operation.

Safe Protection Switch

At the front of joystick installed a safe protection switch, when the switch is pressed down, all crane movement signals have been shielded, and the joystick is useless. This switch can be used to prevent malfunction when operator accessing the cabin and toughing the joystick.

Winch Ratchet Locking Device

Winch drum has a ratchet locking device, and it must be turned on when lowering boom, otherwise boom cannot be lowered. The device is used to stow the boom for safety.

Boom Angle Limit

When boom angle is more than 80°, both load moment limiter and hoist limit switch stop boom raising. When boom angle is less than 30°, load moment limiter stops boom lowering and give a sound warning. The hoist limit switch and load moment limiter may control the tower jib upper/lower limit position.

Monitor System

The monitor system contains 2 cameras and 1 monitor display, respectively keeping watch on main/ auxiliary winch and luffing winch.

Audio/Video Warning

When crawler crane is moving and slewing, there is light and sound for warning.

Tricolor Warning Lamp

The lamp comprises 3 colors, when crane loading is below 90% of total rated lifting load, "Green Lamp" lights on to indicate crane is running in safety area; when crane loading is in 90%~100% of total rated lifting load, "Yellow Lamp" lights on to indicate crane is close to total rated lifting load; when crane loading is above 100%~105% of total rated lifting load, Both "Red Lamp" and "Yellow Lamp" light on at the same time to indicate crane is overload; In dangerous area, control system can automatically cut off crane movement to dangerous direction.

Illumination Lamp

There are illumination lamps at front of turntable, on boom and inside operator's cabin for night operation.

Height Mark Lamp

Boom tip has a height mark lamp for high level operation warning.

Anemometer

Anemometer at boom head can detect current wind speed and send wind signal to a monitor in operator's cabin to alert operator for safety.

自拆装 Self Assembly/Disassembly

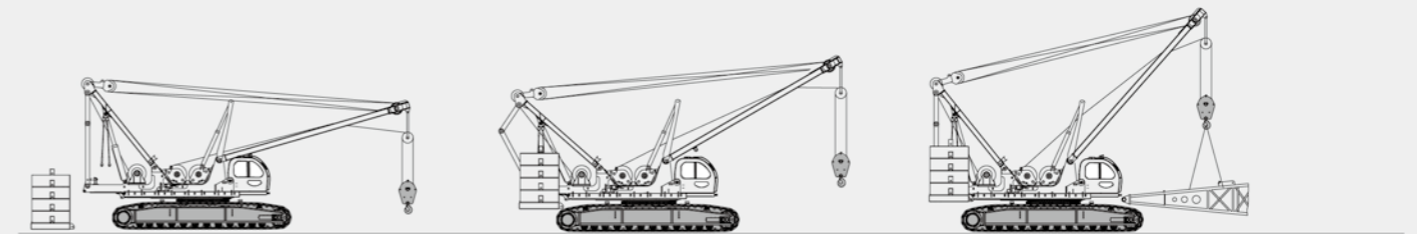
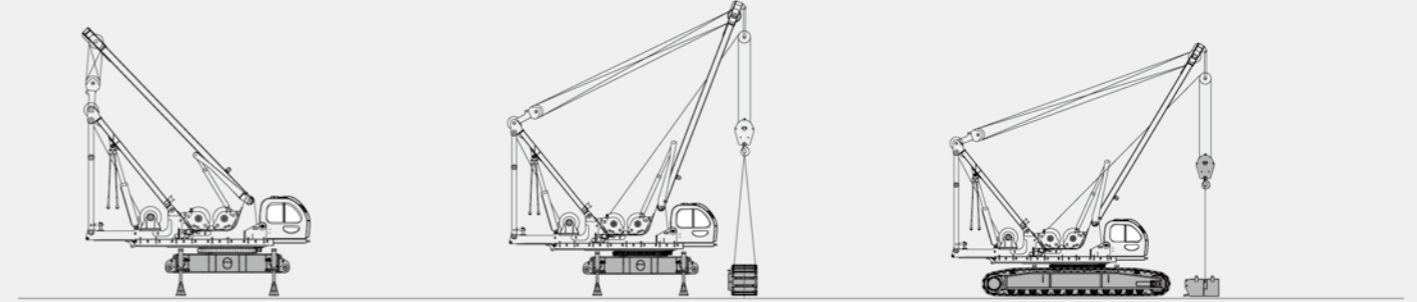

固定副臂安装示意图
Fixed jib installation illustration



塔式副臂安装示意图
Tower jib installation illustration



主臂臂节组合/主臂工况 Boom Combinations/Boom Working Condition

臂长 Boom length (m)	中间臂节 Boom insert		
	3m	6m	12m
18	-	-	-
21	1	-	-
24	-	1	-
27	1	1	-
30	-	-	1
33	1	-	1
36	-	1	1
39	1	1	1
42	-	-	2
45	1	-	2
48	-	1	2
51	1	1	2
54	-	-	3
57	1	-	3
60	-	1	3
63	1	1	3
66	-	-	4
69	1	-	4
72	-	1	4
75	1	1	4
78	-	-	5
81	1	-	5
84	-	1	5
87	1	1	5

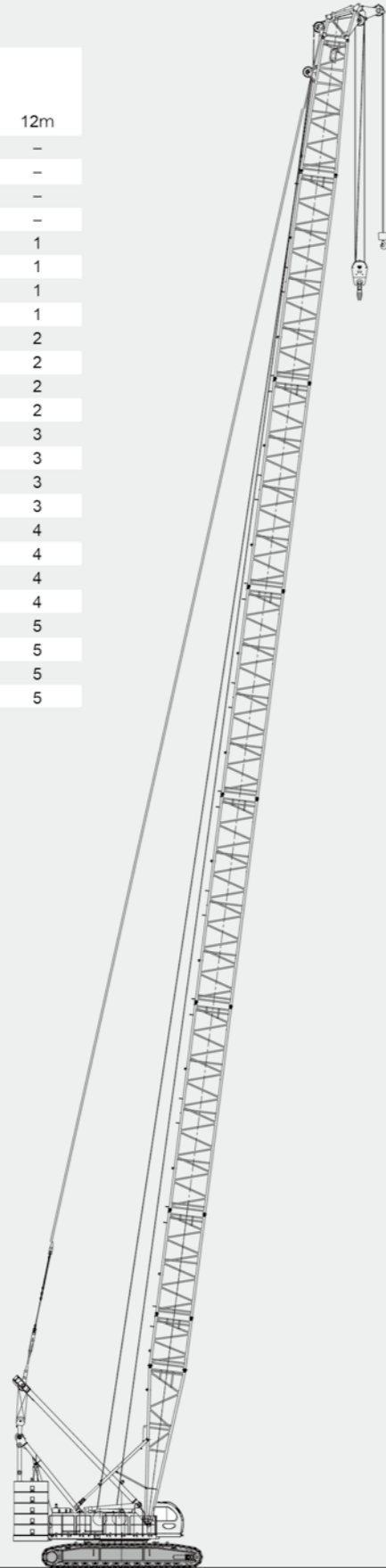

主臂作业范围 Boom Working Area

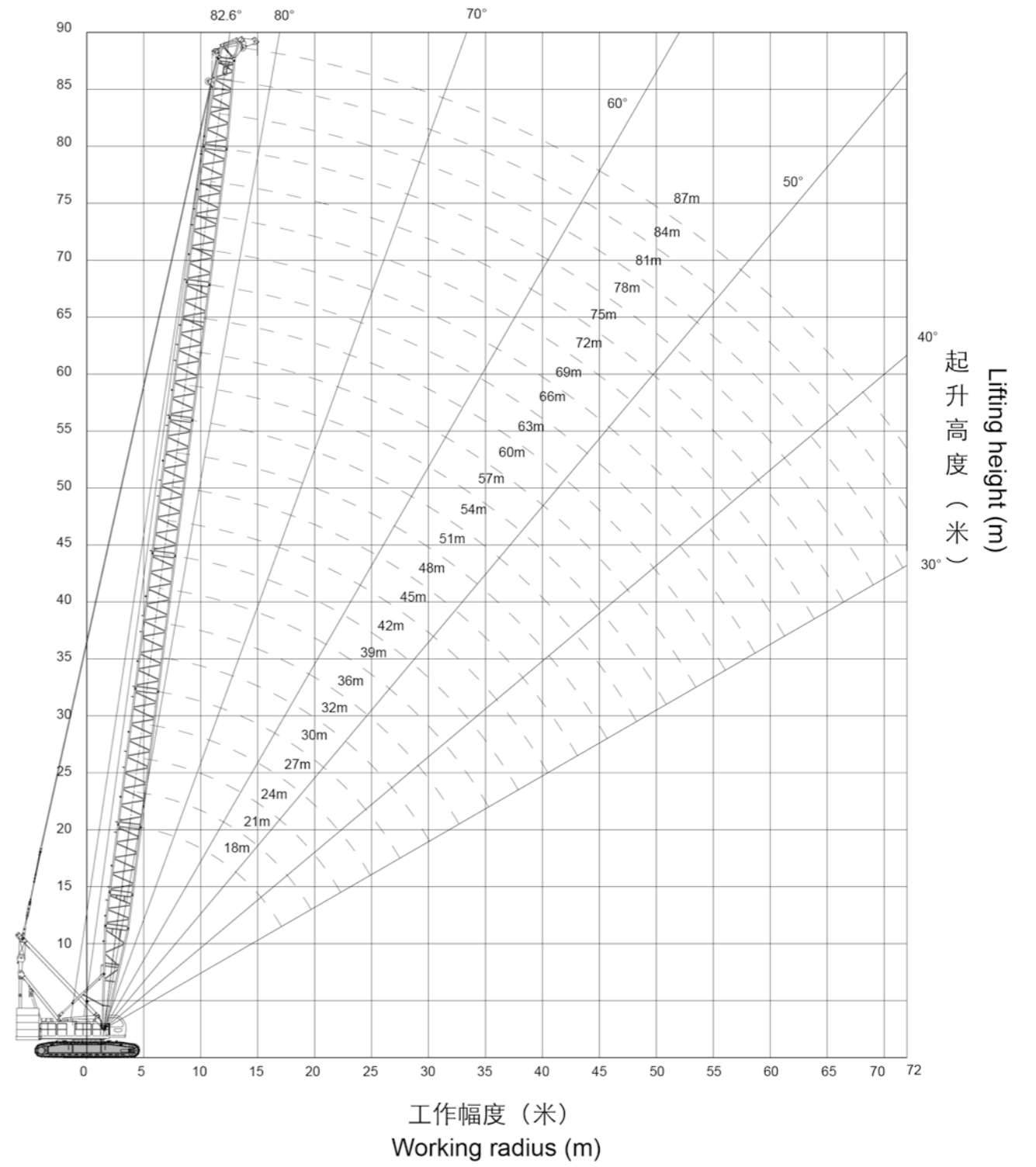

主臂工况载荷表 Boom Lifting Load Chart

幅度Radius (m)	臂长 Boom length (m)											
	18	21	24	27	30	33	36	39	42	45	48	51
4.5	280.0											
5	260.0	260.0	220.3									
6	250.0	240.5	214.6	197.0	178.0							
7	226.3	221.2	210.0	188.2	165.7	163.5	157.5					
8	184.0	180.4	176.9	173.6	165.7	158.6	148.3	145.6	128.6	112.3		
9	154.9	152.2	149.6	147.0	144.6	142.2	139.8	137.5	120.6	110.0	109.3	
10	133.0	131.5	129.4	127.4	125.4	123.5	121.6	119.7	120.0	94.2	106.0	96.7
12	101.9	101.6	101.3	100.2	98.8	97.5	96.1	95.5	95.0	79.0	93.8	95.0
14	85.2	84.5	83.6	83.2	82.9	81.9	80.8	80.1	79.3	67.7	78.2	78.0
16	71.3	71.1	70.5	69.8	69.6	69.3	69.0	68.4	68.2	57.0	66.8	66.6
18	68.1/17.0	62.3	60.3	59.4	59.1	58.6	58.6	58.0	57.7	50.6	56.7	56.4
20		59.1/19.0	53.4	52.8	52.2	51.8	51.4	51.1	51.0	44.8	50.2	50.0
22			47.5	47.1	46.6	46.2	46.0	45.5	45.2	39.8	44.5	44.2
24				42.7	42.3	41.9	41.5	40.5	40.1	35.7	39.5	39.2
26					38.1	37.8	37.4	36.3	36.0	32.2	35.4	35.0
28					36.0/27.0	34.5	34.1	32.9	32.6	29.2	31.8	31.5
30						31.8	31.3	29.9	29.6	26.7	28.9	28.6
32							28.2	27.4	27.0	24.5	26.4	26.0
34								25.2	24.8	22.6	24.2	23.8
36								24.5/35.0	22.9	20.8	22.2	21.8
38									22.0/37.0	19.3	20.5	20.2
40											18.9	18.6
42											17.5	17.2
44											17.1/43.0	16.0
46												15.5/45.0

主臂工况载荷表 Boom Lifting Load Chart

幅度Radius (m)	臂长 Boom length (m)											
	54	57	60	63	66	69	72	75	78	81	84	87
10	96.0	90.0										
12	92.0	85.0	80.0	78.0	70.0	66.3	64.0	60.0	56.0			
14	77.6	76.7	75.7	69.6	69.6	66.3	64.0	58.0	56.0	52.0	46.0	40.0
16	65.8	65.0	64.3	63.4	62.7	62.0	61.1	55.3	55.3	50.0	44.0	38.0
18	56.9	56.2	55.4	54.8	54.1	53.4	52.8	52.1	51.5	48.0	43.1	37.3
20	49.9	49.2	48.6	48.0	47.4	46.7	46.2	45.6	44.9	44.4	41.4	35.9
22	43.9	43.6	43.1	42.5	41.9	41.4	40.8	40.2	39.7	39.2	38.6	34.5
24	38.9	38.5	38.1	37.8	37.4	36.9	36.3	35.8	35.4	34.9	34.3	33.1
26	34.7	34.3	34.0	33.7	33.3	33.0	32.7	32.1	31.7	31.2	30.7	30.2
28	31.2	30.9	30.6	30.1	29.8	29.5	29.2	28.8	28.5	28.0	27.6	27.1
30	28.2	27.9	27.5	27.2	26.9	26.6	26.1	25.8	25.5	25.2	24.8	24.5
32	25.6	25.3	25.0	24.7	24.3	23.9	23.6	23.3	22.9	22.6	22.3	21.9
34	23.4	23.1	22.8	22.5	22.1	21.7	21.4	21.0	20.7	20.4	20.1	19.6
36	21.5	21.1	20.8	20.5	20.2	19.7	19.4	19.1	18.8	18.4	18.1	17.7
38	19.7	19.4	19.1	18.7	18.4	18.1	17.7	17.3	17.0	16.7	16.4	16.0
40	18.3	17.9	17.5	17.2	16.9	16.5	16.2	15.9	15.4	15.1	14.8	14.4
42	16.9	16.5	16.2	15.9	15.4	15.1	14.8	14.4	14.1	13.8	13.4	13.0
44	15.6	15.2	14.9	14.6	14.2	13.9	13.5	13.2	12.8	12.5	12.2	11.8
46	14.5	14.2	13.8	13.4	13.1	12.7	12.4	12.1	11.7	11.3	11.0	10.7
48	13.4	13.1	12.8	12.4	12.1	11.8	11.3	11.0	10.7	10.3	10.0	9.7
50		12.2	11.9	11.4	11.1	10.8	10.4	10.1	9.8	9.3	9.0	8.7
52			10.9	10.6	10.3	9.9	9.6	9.2	8.8	8.5	8.3	8.0
54			10.5/53.0	9.8	9.5	9.1	8.7	8.4	8.1	7.9	7.6	7.2
56				9.0	8.7	8.4	8.0	7.8	7.5	7.1	6.9	6.6
58					7.8	7.4	7.1	6.8	6.8	6.5	6.3	5.7
60						6.8	6.5	6.2	6.0	5.7	5.4	5.2
62						6.3/61.0	6.0	5.7	5.5	5.2	4.9	4.7
64								5.3	5.0	4.7	4.5	4.2
66								4.8	4.6	4.3	4.0	3.7
68									4.1	3.9	3.6	3.3
70									3.3/69	3.5	3.2	2.9
72										2.2/71.0	2.9	2.6
74											2.5	
76												

固定副臂臂节组合/副臂工况 Fixed Jib Combinations/Jib Working Condition

副臂长度 Jib length (m)	中间节臂 Jib insert (m)	主臂长度 Boom length (m)	主副臂夹角 Angle between boom and jib (°)
12	-	45~75	10, 30
18	1	45~75	10, 30
24	2	45~75	10, 30
30	3	45~75	10, 30
36	4	45~75	10, 30

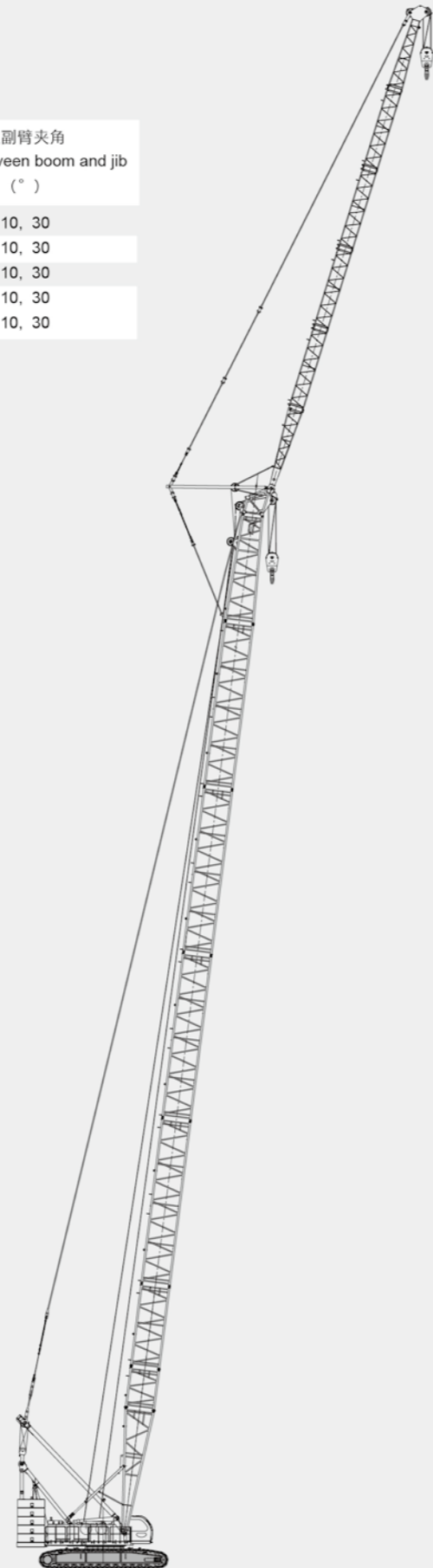

固定副臂作业范围 Fixed Jib Working Area

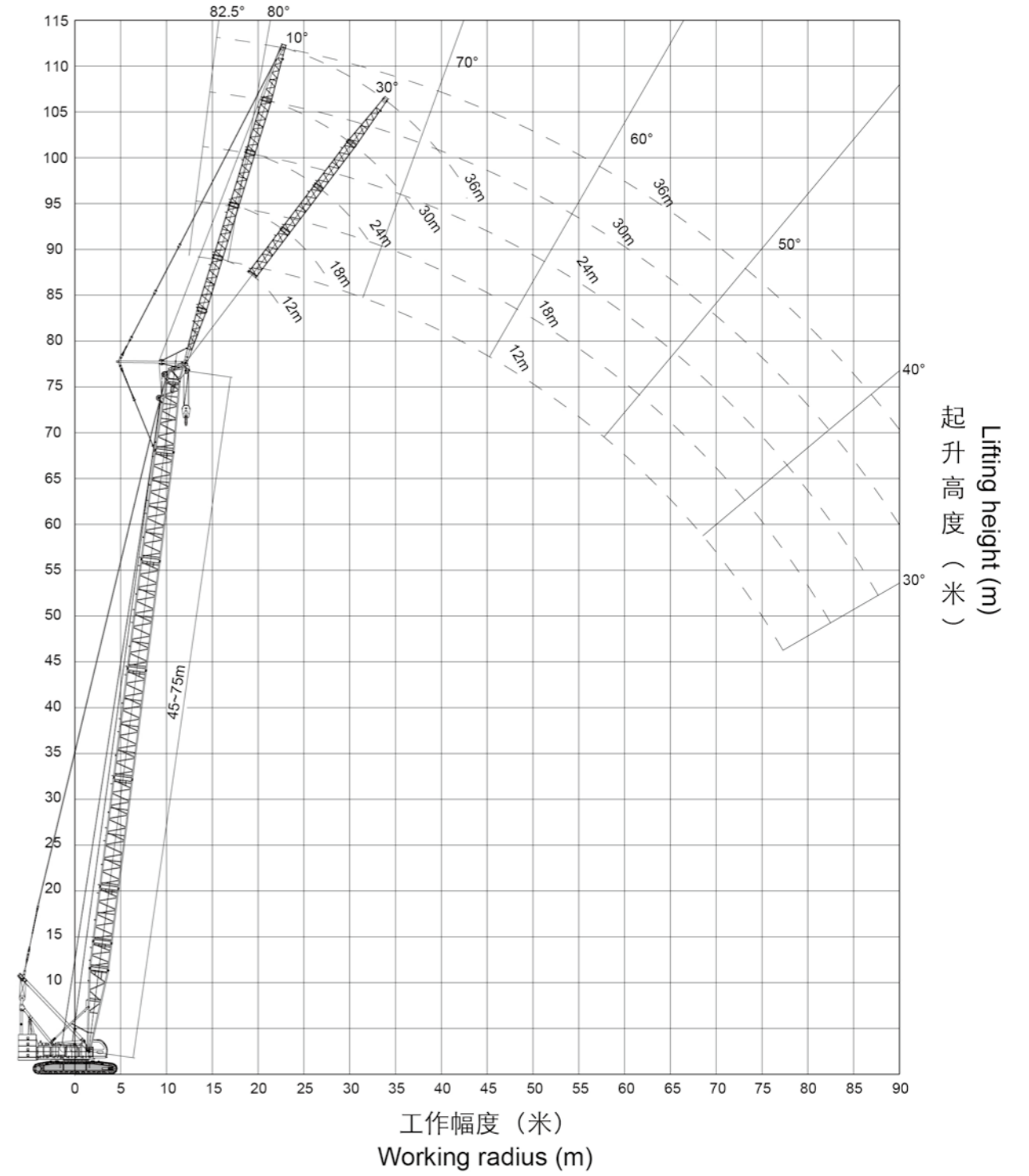

固定副臂工况载荷表 Fixed Jib Lifting Load Chart

主臂长度 Boom length (m)		主臂45米 Boom length 45m									
副臂长度 Jib length (m)		12		18		24		30		36	
幅度 Radius (m)		安装角 Offset angle (°)									
		10	30	10	30	10	30	10	30	10	30
14		37.0		26.0/14.5							
16		35.7	25.0/17.0	25.8		18.5					
18		35.0	24.5	25.2		18.4		13.2			
20		34.3	24.2	24.4	20.0/21.0	18.0		12.9		8.1	
22		33.7	24.0	23.7	19.2	17.6		12.6		7.8	
24		33.1	23.8	22.9	18.7	17.2	14.2	12.3		7.7	
26		31.8	23.6	22.3	18.1	16.8	13.9	12.0		7.5	
28		30.9	23.3	21.6	17.6	16.4	11.1	11.7	9.2	7.4	
30		29.9	22.7	21.0	17.0	16.0	10.8	11.4	8.7	7.3	
32		27.2	22.1	20.5	16.5	15.7	10.4	11.2	8.4	7.2	6.2
34		24.8	21.6	19.9	16.1	15.4	10.1	10.8	8.2	7.0	6.1
36		22.7	21.1	19.5	15.6	14.9	9.9	10.3	8.0	6.9	6.0
38		20.8	20.7	19.0	15.2	14.5	9.6	9.9	7.8	6.8	5.8
40		19.2	19.7	18.3	14.9	14.1	9.4	9.5	7.6	6.7	5.7
42		17.7	18.2	17.6	14.5	13.7	9.1	9.2	7.4	6.6	5.5
44		16.4	16.8	16.9	14.2	10.8	8.9	8.8	7.3	6.5	5.4
46		15.1	15.5	15.7	13.9	10.5	8.7	8.5	7.1	6.4	5.2
48		14.0	14.3	14.6	13.6	10.1	8.5	8.3	7.0	6.3	5.1
50		13.0	13.2	13.6	13.4	9.8	8.4	8.0	6.9	6.1	4.9
52			12.2	12.2	11.0	9.5	8.3	7.8	6.7	5.9	4.8
54				11.8	10.8	9.2	8.1	7.6	6.6	5.7	4.7
56				11.0	10.7	9.0	8.0	7.4	6.5	5.5	4.6
58					10.4	8.7	7.9	7.2	6.4	5.3	4.5
60						8.5	7.8	7.0	6.3	5.2	4.4
62						8.3	7.7	6.9	6.2	5.0	4.3
64							7.7	6.7	6.1	4.9	4.2
66								6.6	6.1	4.7	4.2
68								6.4	6.0	4.6	4.1
70									6.0	4.5	4.0
72										4.4	4.0
74										4.3	4.0
76											4.0

固定副臂工况载荷表 Fixed Jib Lifting Load Chart

主臂长度 Boom length (m)		主臂54米 Boom length 54m									
副臂长度 Jib length (m)		12		18		24		30		36	
幅度 Radius (m)		安装角 Offset angle (°)									
		10	30	10	30	10	30	10	30	10	30
16		37.0									
18		35.7	25.0	25.7		18.5					
20		35.1	24.5	25.2		18.3		13.0			
22		34.5	24.2	24.4	20.0	18.0		12.9		7.8	
24		33.9	24.0	23.8	19.1	17.6		12.6		7.7	
26		33.4	23.8	23.1	18.7	17.2	14.0	12.3		7.6	
28		32.1	23.6	22.5	18.2	16.9	13.8	12.0		7.5	
30		28.9	23.3	21.9	17.7	16.6	11.1	11.8	9.0	7.4	
32		26.1	23.0	21.4	17.2	16.2	10.8	11.5	8.6	7.3	6.2
34		23.7	22.5	20.9	16.7	15.9	10.5	11.3	8.4	7.2	6.2
36		21.6	22.1	20.4	16.3	15.6	10.2	11.1	8.2	7.1	6.1
38		19.8	20.5	19.9	15.9	15.3	10.0	10.6	8.0	7.0	6.0
40		18.1	18.8	18.7	15.6	14.9	9.7	10.2	7.8	6.9	5.8
42		16.6	17.3	17.2	15.2	14.6	9.5	9.9	7.7	6.8	5.7
44		15.3	15.9	15.9	14.9	14.2	9.3	9.5	7.5	6.7	5.5
46		14.1	14.6	14.7	14.6	13.8	9.1	9.2	7.4	6.6	5.4
48		13.0	13.4	13.5	14.3	13.3	8.9	8.9	7.3	6.5	5.3
50		11.9	12.3	12.5	11.6	10.6	8.8	8.6	7.1	6.4	5.2
52		11.0	11.4	11.6	11.4	10.3	8.6	8.4	7.0	6.3	5.0
54		10.2	10.4	10.7	11.2	10.1	8.4	8.1	6.9	6.1	4.9
56		9.4	9.6	9.9	10.4	9.8	8.3	7.9	6.8	6.0	4.8
58		8.6	8.8	9.1	9.6	9.5	8.2	7.7	6.6	5.8	4.7
60			8.1	8.4	8.8	8.9	8.1	7.6	6.5	5.6	4.6
62				7.8	8.1	8.2	8.0	7.4	6.4	5.5	4.5
64				7.2	7.4	7.6	7.9	7.2	6.4	5.3	4.5
66					6.8	7.0	7.5	7.1	6.3	5.2	4.4
68						6.5	6.8	6.8	6.2	5.0	4.3
70						6.0	6.3	6.3	6.1	4.9	4.2
72							5.8	5.9	6.1	4.8	4.2
74								5.5	5.8	4.7	4.1
76								5.1	5.4	4.5	4.1
78									4.9	4.4	4.0
80										4.3	4.0
82										4.2	4.0
84											4.0

固定副臂工况载荷表 Fixed Jib Lifting Load Chart

主臂长度 Boom length (m)		主臂63米 Boom length 63m									
副臂长度 Jib length (m)		12		18		24		30		36	
幅度 Radius (m)	安装角 Offset angle (°)										
	10	30	10	30	10	30	10	30	10	30	
18	36.5		26.0								
20	35.7	25.0	25.7		18.5		13.0				
22	35.2	24.5	25.1	20.0	18.3		13.0		8.0		
24	34.6	24.2	24.4	20.0	17.9		12.8		7.8		
26	34.1	24.0	23.8	19.1	17.6	14.0	12.6		7.7		
28	31.1	23.8	23.3	18.6	17.3	14.0	12.3		7.6		
30	27.9	23.6	22.7	18.2	17.0	13.8	12.1	9.0	7.5		
32	25.1	23.4	22.2	17.7	16.7	11.0	11.8	9.0	7.4		
34	22.7	23.3	21.7	17.3	16.4	10.8	11.6	8.6	7.3	6.2	
36	20.6	21.6	21.2	16.9	16.1	10.5	11.4	8.4	7.2	6.2	
38	18.7	19.7	19.4	16.5	15.8	10.3	11.2	8.2	7.1	6.1	
40	17.1	17.9	17.7	16.2	15.6	10.1	10.8	8.0	7.0	6.0	
42	15.6	16.4	16.2	15.9	15.2	9.9	10.5	7.8	6.9	5.8	
44	14.2	14.9	14.9	15.5	14.9	9.7	10.1	7.7	6.8	5.7	
46	13.0	13.7	13.6	14.6	14.1	9.4	9.8	7.6	6.7	5.6	
48	11.9	12.5	12.5	13.4	11.7	9.3	9.5	7.5	6.7	5.5	
50	10.9	11.4	11.5	12.0	11.4	9.1	9.2	7.3	6.6	5.3	
52	10.0	10.4	10.5	11.3	11	8.9	8.9	7.2	6.5	5.2	
54	9.1	9.5	9.6	10.4	10.1	8.8	8.7	7.1	6.4	5.1	
56	8.3	8.7	8.8	9.5	9.3	8.6	8.4	7.0	6.4	5.0	
58	7.6	7.9	8.1	8.7	8.5	8.5	8.2	6.9	6.2	4.9	
60	7.0	7.2	7.4	7.9	7.8	8.4	8.1	6.8	6.0	4.8	
62	6.4	6.6	6.8	7.2	7.2	7.9	7.6	6.7	5.9	4.7	
64	5.9	6.0	6.3	6.6	6.7	7.3	7.0	6.6	5.7	4.6	
66	5.3	5.5	5.8	6.1	6.1	6.7	6.4	6.5	5.6	4.5	
68		5.0	5.3	5.6	5.7	6.1	6.0	6.4	5.4	4.5	
70			4.8	5.1	5.2	5.6	5.5	6.1	5.3	4.4	
72			4.4	4.6	4.8	5.1	5.1	5.6	5.2	4.3	
74				4.2	4.4	4.7	4.7	5.2	4.9	4.3	
76					4.0	4.3	4.3	4.7	4.5	4.2	
78						3.6	3.8	3.9	4.3	4.1	4.2
80							3.4	3.6	3.9	3.8	4.1
82								3.2	3.5	3.5	4.0
84								2.9	3.2	3.2	3.6
86									2.8	2.8	3.2
88										2.6	2.9
90											2.5
92											2.2

固定副臂工况载荷表 Fixed Jib Lifting Load Chart

主臂长度 Boom length (m)		主臂63米 Boom length 63m									
副臂长度 Jib length (m)		12		18		24		30		36	
幅度 Radius (m)	安装角 Offset angle (°)										
	10	30	10	30	10	30	10	30	10	30	
20	36.5										
22	35.9	25.0	25.7		18.5						
24	35.4	24.5	25.3		18.3		13.0				
26	32.8	24.2	24.6	20.0	18.0		12.9		7.8		
28	29.4	24.0	24.1	19.1	17.7		12.6		7.7		
30	26.5	23.8	23.6	18.8	17.4	14.0	12.4		7.7		
32	23.8	23.6	23.1	18.3	17.2	13.8	12.2	9.0	7.6		
34	21.4	22.7	22.1	17.9	16.9	11.1	12.0	8.7	7.5		
36	19.2	20.4	20.0	17.6	16.6	10.9	11.8	8.6	7.4	6.2	
38	17.4	18.5	18.1	17.2	16.4	10.6	11.6	8.4	7.3	6.2	
40	15.7	16.7	16.4	16.9	16.1	10.4	11.4	8.3	7.2	6.1	
42	14.2	15.1	14.9	16.3	15.4	10.2	11.2	8.1	7.1	6.0	
44	12.9	13.7	13.5	14.8	14.1	10.0	10.9	7.9	7.0	5.9	
46	11.6	12.4	12.3	13.5	12.8	9.9	10.5	7.8	6.9	5.8	
48	10.5	11.3	11.1	12.3	11.7	9.7	10.2	7.7	6.9	5.6	
50	9.5	10.2	10.1	11.2	10.6	9.5	9.9	7.6	6.8	5.5	
52	8.6	9.2	9.1	10.1	9.6	9.3	9.7	7.5	6.7	5.4	
54	7.8	8.3	8.3	9.2	8.8	9.2	9.2	7.3	6.6	5.3	
56	7.1	7.5	7.6	8.3	8.0	9.0	8.4	7.3	6.6	5.2	
58	6.4	6.9	6.9	7.6	7.3	8.3	7.6	7.2	6.5	5.1	
60	5.8	6.2	6.3	6.9	6.7	7.5	7.0	7.0	6.4	5.0	
62	5.2	5.6	5.7	6.3	6.1	6.9	6.4	7.0	6.3	4.9	
64	4.7	5.0	5.2	5.7	5.5	6.3	5.9	6.9	6.1	4.9	
66	4.2	4.5	4.6	5.1	5.0	5.7	5.3	6.3	5.6	4.8	
68	3.7	4.0	4.2	4.6	4.5	5.2	4.9	5.7	5.1	4.7	
70	3.3	3.5	3.7	4.1	4.1	4.7	4.4	5.2	4.7	4.6	
72	2.9	3.1	3.3	3.7	3.7	4.2	4.0	4.7	4.2	4.6	
74	2.5	2.6	2.9	3.2	3.2	3.8	3.6	4.3	3.8	4.5	
76	2.1	2.2	2.5	2.8	2.9	3.4	3.2	3.9	3.4	4.3	
78		1.8	2.1	2.4	2.5	2.9	2.8	3.4	3.1	3.9	
80			1.8	2.0	2.2	2.6	2.5	3.0	2.7	3.5	
82					1.8	2.2	2.1	2.7	2.4	3.1	
84						1.8	1.8	2.3	2.1	2.7	
86								2.0	1.8	2.4	
88										2.0	

塔式副臂臂节组合/塔臂工况 Tower Jib Combinations/Tower Jib Working Condition

副臂长度 Jib length (m)	中间节臂 Jib insert			主臂长度 Boom length (m)	主臂角度 Boom angle (°)
	3m	6m	12m		
27	1	1	-	30-60	65, 75, 85
30	-	-	1	30-60	65, 75, 85
33	1	-	1	30-60	65, 75, 85
36	-	1	1	30-60	65, 75, 85
39	1	1	1	30-60	65, 75, 85
42	-	-	2	30-60	65, 75, 85
45	1	-	2	30-60	65, 75, 85
48	-	1	2	30-60	65, 75, 85
51	1	1	2	30-60	65, 75, 85
54	-	2	2	30-60	65, 75, 85
57	1	2	2	30-60	65, 75, 85
60	2	2	2	30-60	65, 75, 85

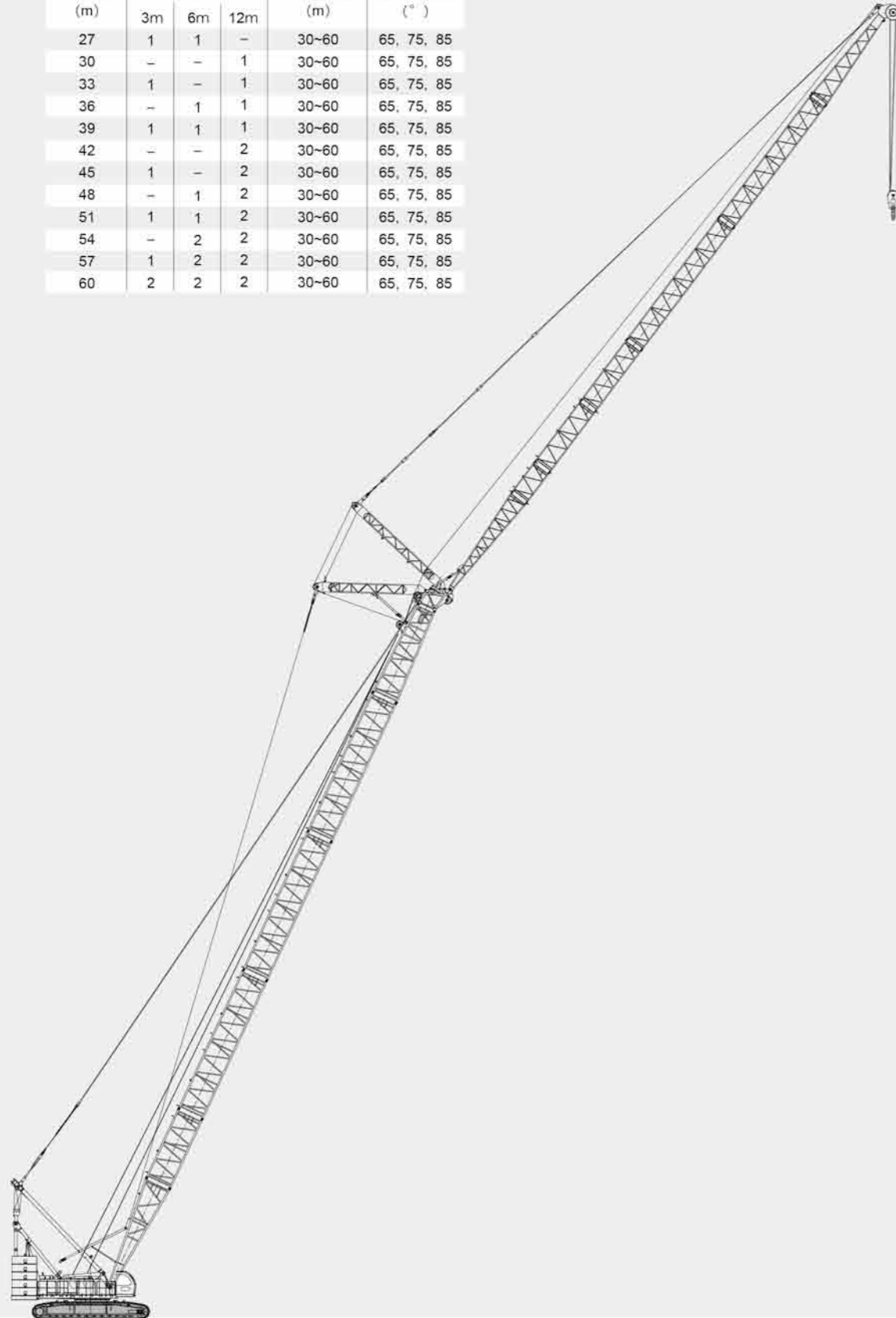

塔式副臂作业范围 Tower Jib Working Area

主臂85°时 Boom angle at 85°

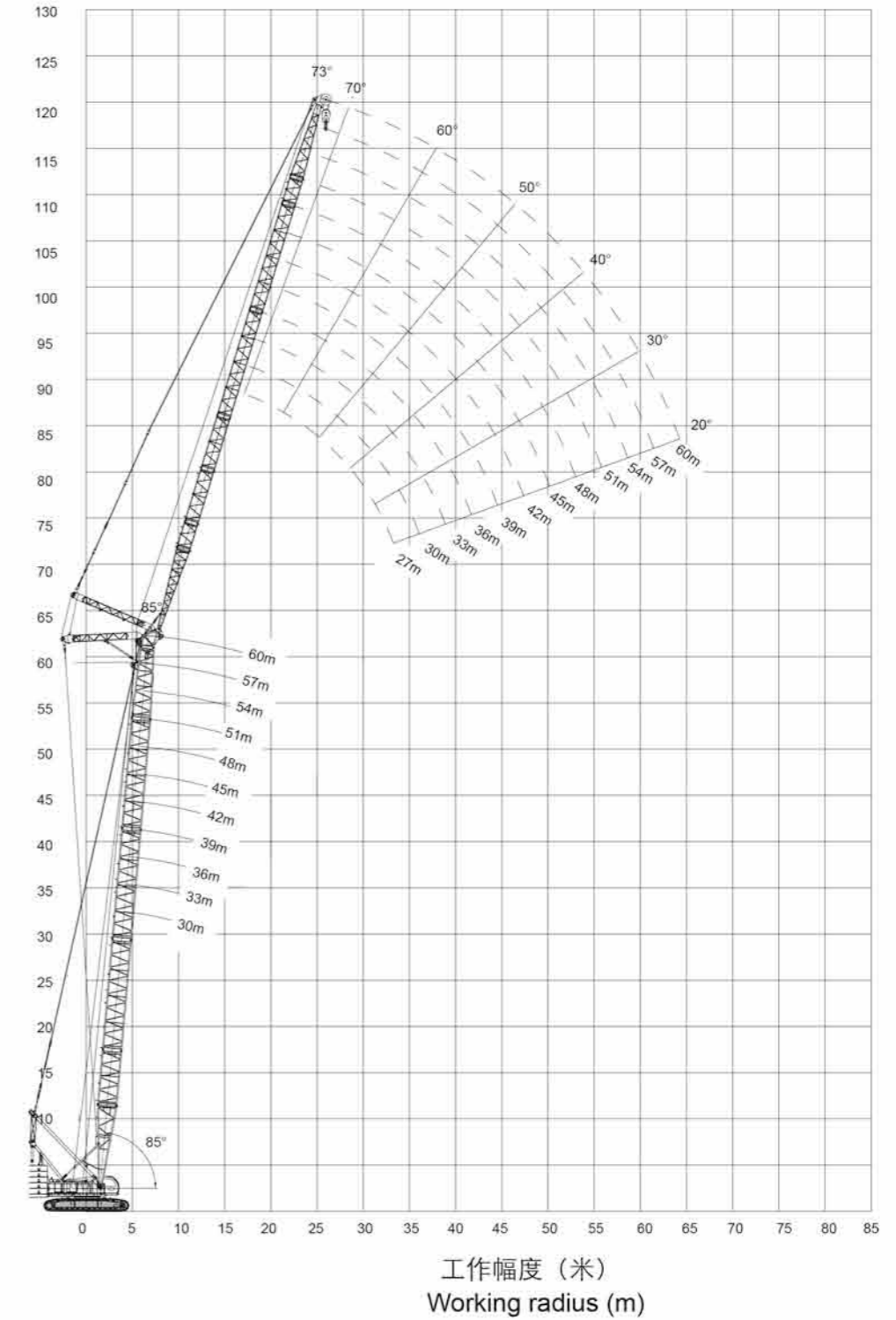

起升高度 (米)
Lifting height (m)

工作幅度 (米)
Working radius (m)

塔式副臂作业范围 Tower Jib Working Area

塔式副臂作业范围 Tower Jib Working Area

主臂75°时 Boom angle at 75°

主臂65°时 Boom angle at 65°

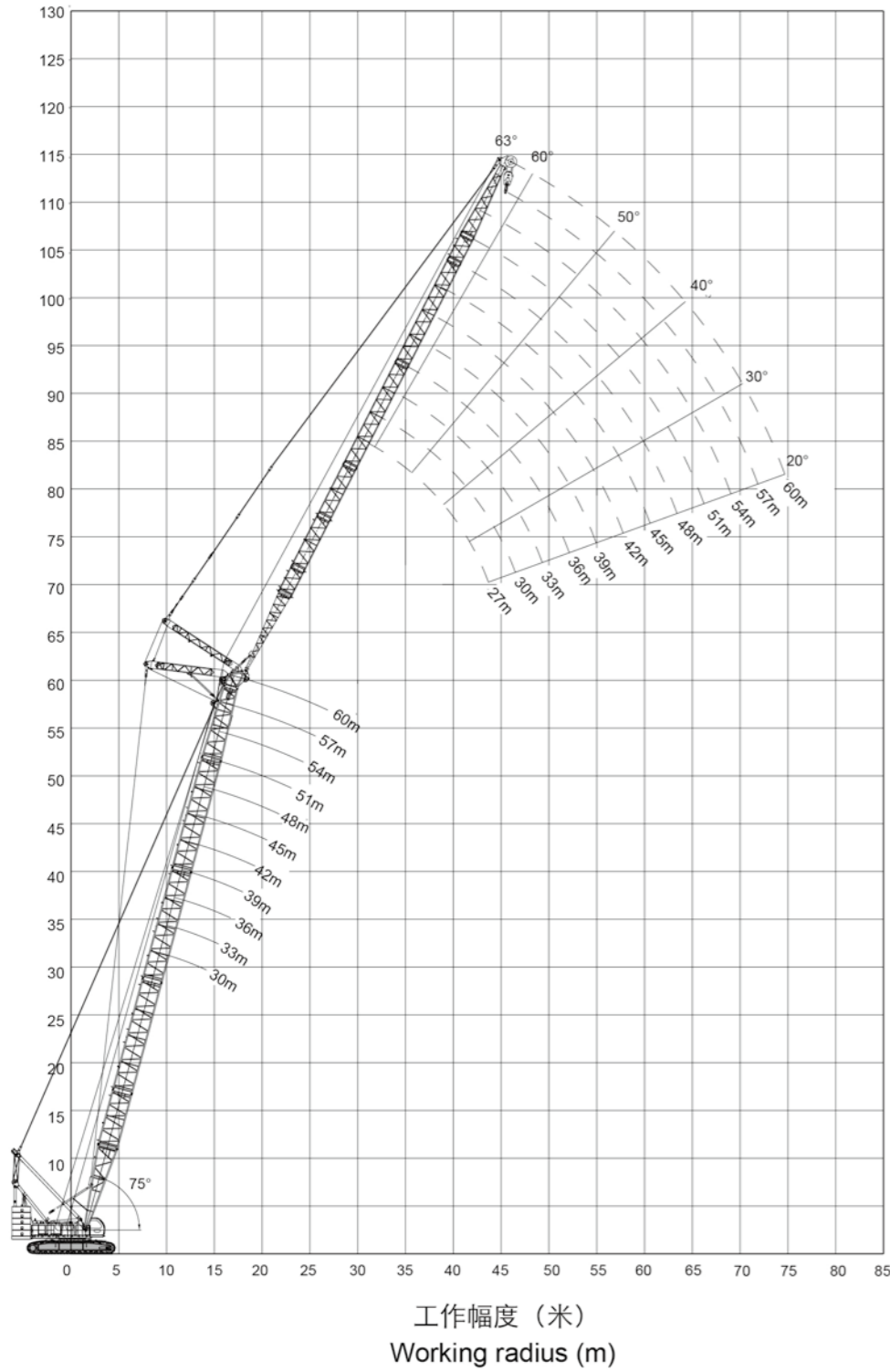

起升高度 (米)
Lifting height (m)

起升高度 (米)
Lifting height (m)

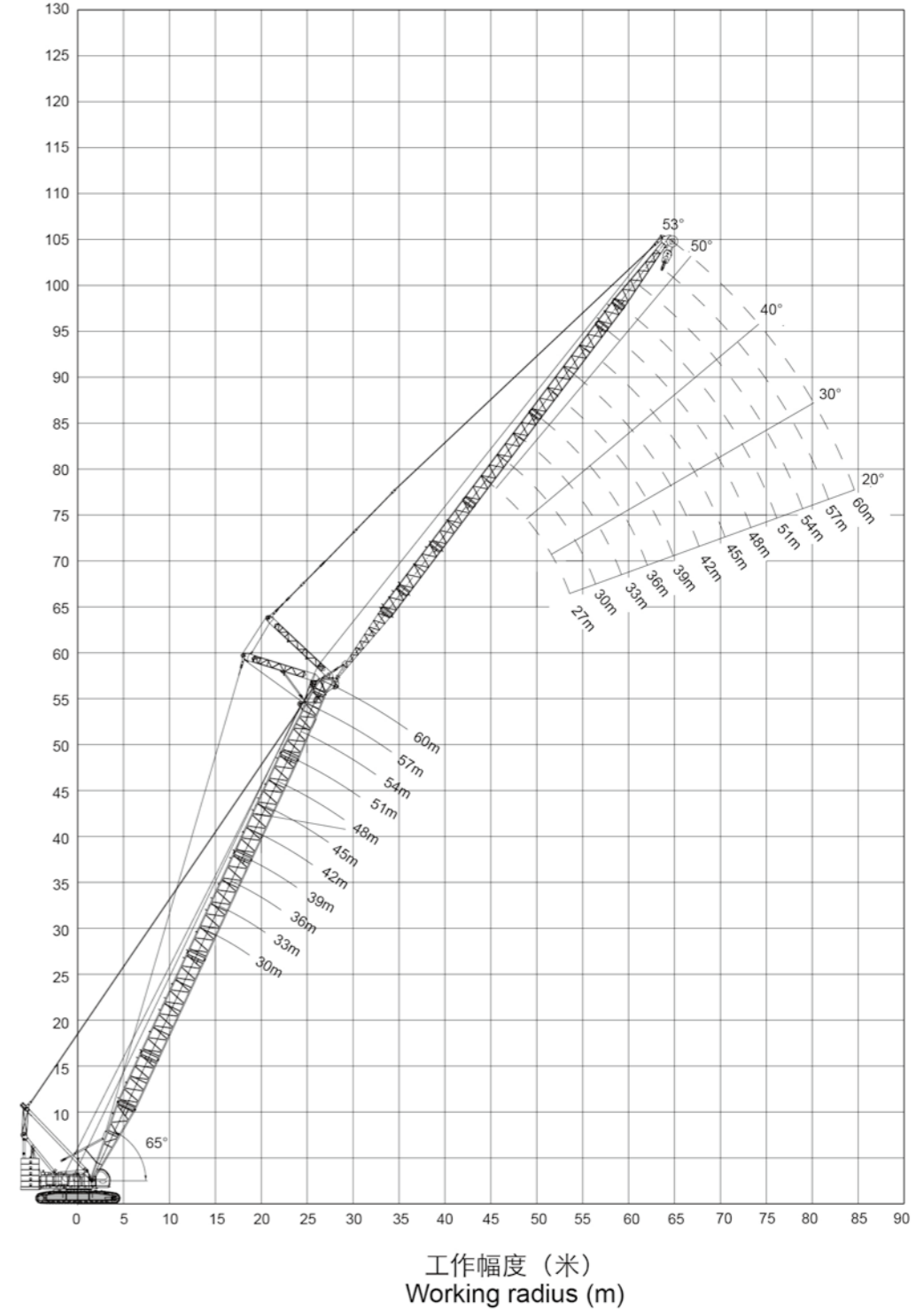

塔式副臂工况载荷表 Tower Jib Lifting Load Chart

主臂长度 Boom length (m)		主臂30米 Boom length 30m								
塔臂长度 Tower jib length (m)		27			33			39		
幅度 Radius (m)	主臂角度 Boom angle (°)									
	85	75	65	85	75	65	85	75	65	
14	78.0			54.2/15.4						
16	67.7			54.2			45.7/17.1			
18	59.9			53.5			44.7			
20	53.3			52.1			43.7			
22	47.9			46.9			42.6			
24	43.2	40.1		42.5			39.3			
26	39.1	36.3		38.7	35.8		37.1			
28	35.7	33.1		35.3	32.6		34.8	31.5/29.0		
30	32.8	30.4		32.4	29.9		31.9	29.4		
32		28.1	26.0	29.9	27.6		29.5	27.1		
34		26.1	24.1	27.7	25.6		27.3	25.1		
36		24.3	22.5	25.8	23.8	21.9	25.4	23.3		
38			21.0		22.2	20.5	23.7	21.8		
40			19.7		20.8	19.2	22.2	20.4	18.6	
42					19.6	18.0	20.9	19.1	17.5	
44						16.9		18.0	16.4	
46						16.0		17.0	15.5	
48								16.0	14.6	
50									13.8	
52									13.1	

主臂长度 Boom length (m)		主臂30米 Boom length 30m								
塔臂长度 Tower jib length (m)		45			51			60		
幅度 Radius (m)	主臂角度 Boom angle (°)									
	85	75	65	85	75	65	85	75	65	
18	31.5/19.0									
20	30.7			21.1/20.7						
22	30.0			20.4			10.5/23.5			
24	29.2			19.8			10.4			
26	28.4			19.3			10.0			
28	26.7			18.8			9.7			
30	26.2			18.3			9.4			
32	25.8	26.6		17.8			9.1			
34	25.3	24.6		17.3			8.8			
36	24.8	22.9		17.0	15.2		8.5			
38	23.3	21.3		16.6	14.8		8.3	9.1		
40	21.8	19.9		16.3	14.4		8.1	8.7		
42	20.4	18.7	17.0/43.0	15.9	14.0		7.8	8.5		
44	19.2	17.5	15.9	15.1	13.7		7.6	8.2		
46	18.1	16.5	15.0	14.4	13.3	14.1/47.0	7.4	8.0		
48	17.1	15.6	14.1	13.7	12.0	13.6	7.0	7.8		
50		14.7	13.3	12.1	11.5	12.8	6.7	7.6		
52		14.0	12.6	11.7	10.9	12.1	6.3	7.3	8.0	
54		13.2	11.9	11.3	10.4	11.5	6.0	7.0	7.8	
56			11.3		9.9	10.8	5.7	6.6	7.5	
58			10.8		9.4	10.3	5.5	6.3	7.2	
60					9.0	9.8	5.2	6.0	6.9	
62					8.7	9.3	5.0	5.7	6.5	
64						8.8		5.5	6.2	
66								5.2	5.7	
68								5.1	5.7	
70									5.3	
72									5.1	

塔式副臂工况载荷表 Tower Jib Lifting Load Chart

主臂长度 Boom length (m)		主臂42米 Boom length 42m								
塔臂长度 Tower jib length (m)		27			33			39		
幅度 Radius (m)	主臂角度 Boom angle (°)									
	85	75	65	85	75	65	85	75	65	
14	68.0/14.6									
16	63.0				54.2					
18	55.3				53.5			45.1		
20	49.2				48.2			44.2		
22	44.4				43.4			42.5		
24	40.3				39.4			38.6		
26	37.0	33.0/26.5			36.1			35.3		
28	34.0	30.7			33.3			32.5		
30	31.2	28.3			30.8	27.6		30.1		
32		26.1			28.5	25.6		28.0	25.0	
34		24.3			26.4	23.8		26.0	23.3	
36		22.6	20.3/37.0		24.6	22.1		24.2	21.6	
38		21.2	19.0			20.7		22.6	20.2	
40			17.8			19.4	17.1/41.0	21.2	18.9	
42			16.8			18.2	16.2	19.9	17.8	
44			15.8			17.2	15.3		16.7	14.8/44.5
46							14.4		15.8	13.9
48							13.6		14.9	13.1
50							12.9		14.1	12.4
52										11.8
54										11.2
56										10.6

塔式副臂工况载荷表 Tower Jib Lifting Load Chart

主臂长度 Boom length (m)		主臂42米 Boom length 42m								
塔臂长度 Tower jib length (m)		45			51			60		
幅度 Radius (m)		主臂角度 Boom angle (°)								
		85	75	65	85	75	65	85	75	65
20	31.1									
22	30.3				20.8					
24	29.6				20.1			10.6/24.5		
26	28.8				19.6			10.2		
28	28.0				19.1			9.9		
30	26.5				18.5			9.6		
32	26.0				18.0			9.3		
34	25.5	22.0/34.5			17.5			8.9		
36	23.8	21.1			17.2			8.6		
38	22.2	19.7			16.8	18.4		8.4		
40	20.8	18.4			16.4	17.9		8.2	9.2/41.0	
42	19.5	17.3			16.1	16.8		8.0	8.9	
44	18.4	16.3			15.5	15.8		7.8	8.6	
46	17.3	15.3			14.7	14.9		7.6	8.4	
48	16.4	14.5	12.6		14.0	14.0		7.2	8.1	
50		13.7	11.9		13.4	13.2		6.9	7.9	
52		13.0	11.3		11.9	12.5	10.8	6.5	7.7	
54		12.3	10.7		11.5	11.9	10.2	6.2	7.5	
56			10.1			11.2	9.6	5.9	7.2	7.9/57.0
58			9.6			10.7	9.1	5.6	6.8	7.7
60			9.1			10.2	8.7	5.4	6.5	7.4
62			8.7				8.2	5.1	6.2	7.0
64							7.8		5.9	6.7
66							7.4		5.6	6.4
68							7.1		5.4	6.0
70									5.2	5.7
72										5.4
74										5.1
76										5.1

塔式副臂工况载荷表 Tower Jib Lifting Load Chart

主臂长度 Boom length (m)		主臂48米 Boom length 48m								
塔臂长度 Tower jib length (m)		27			33			39		
幅度 Radius (m)		主臂角度 Boom angle (°)								
		85	75	65	85	75	65	85	75	65
14	68.0/15.2									
16	61.5				53.5/17.0					
18	54.1				52.9			45.3/18.7		
20	48.2				47.2			44.5		
22	43.5				42.5			41.6		
24	39.6				38.7			37.8		
26	36.3				35.4			34.6		
28	33.5	29.4			32.7			31.9		
30	31.0	27.3			30.3	25.5/31.0		29.6		
32		25.4			28.2	24.6		27.5		
34		23.5			26.2	23.0		25.7	22.3	
36		21.9			24.4	21.4		24.0	20.9	
38		20.5				20.0		22.4	19.5	
40		19.2	16.8			18.8		21.0	18.3	
42			15.8			17.6		19.7	17.2	
44			14.9			16.6	14.3		16.1	
46			14.0				13.5		15.2	13.0/47.0
48							12.8		14.4	12.2
50							12.1		13.6	11.6
52							11.5			11.0
54										10.4
56										9.9
58										9.4

塔式副臂工况载荷表 Tower Jib Lifting Load Chart

主臂长度 Boom length (m)		主臂48米 Boom length 48m								
塔臂长度 Tower jib length (m)		45			51			60		
幅度 Radius (m)		主臂角度 Boom angle (°)								
		85	75	65	85	75	65	85	75	65
20	31.3/20.5									
22	30.6				21.0/22.2					
24	29.9				20.3			10.5/25.0		
26	29.1				19.7			10.3		
28	28.3				19.2			9.9		
30	26.7				18.7			9.7		
32	26.2				18.2			9.4		
34	25.0				17.6			9.0		
36	23.5	20.2			17.3			8.7		
38	22.0	18.9			16.9	18.3/39.0		8.4		
40	20.6	17.8			16.5	17.2		8.2		
42	19.3	16.7			16.2	16.2		8.0	9.1/43.0	
44	18.2	15.7			15.7	15.2		7.8	8.8	
46	17.2	14.8			15.0	14.3		7.6	8.5	
48	16.2	13.9			14.2	13.5		7.3	8.3	
50		13.2	11.1/51.0		13.6	12.7		7.0	8.1	
52		12.5	10.4		12.0	12.0		6.6	7.9	
54		11.8	9.9		11.6	11.4	9.4	6.3	7.7	
56		11.2	9.4			10.8	8.9	6.0	7.5	
58			8.9			10.2	8.4	5.7	7.1	
60			8.4			9.7	7.9	5.4	6.7	6.8
62			8.0			9.2	7.5	5.2	6.4	6.4
64			7.6				7.1		6.1	6.1
66							6.8		5.8	5.7
68							6.4		5.5	5.4
70							6.1		5.3	5.1
72										4.8
74										4.6
76										4.3
78										4.2

塔式副臂工况载荷表 Tower Jib Lifting Load Chart

主臂长度 Boom length (m)		主臂54米 Boom length 54m								
塔臂长度 Tower jib length (m)		27			33			39		
幅度 Radius (m)		主臂角度 Boom angle (°)								
		85	75	65	85	75	65	85	75	65
16	60.0				53.5/17.5					
18	52.9				51.7			45.0/19.2		
20	47.2				46.1			44.6		
22	42.6				41.6			40.7		
24	38.8				37.9			37.0		
26	35.6				34.7			33.9		
28	32.9				32.0			31.3		
30	30.6	26.0			29.7			29.0		
32	28.4	24.2			27.7	23.5/32.5		27.0		
34		22.7			25.8	21.9		25.1	20.2/35.0	
36		21.2			24.0	20.6		23.3	19.8	
38		19.8			22.5	19.3		21.7	18.6	
40		18.6				18.1		20.3	17.6	
42				14.7/42.5		17.0		19.0	16.5	
44				13.9		16.0			15.5	
46				13.1		15.1	12.5		14.6	
48				12.4			11.8		13.8	
50				11.7			11.2		13.1	10.7
52							10.6		12.4	10.1
54							10.1			9.5
56							9.6			9.0
58										8.6
60										8.2

塔式副臂工况载荷表 Tower Jib Lifting Load Chart

主臂长度 Boom length (m)		主臂54米 Boom length 54m								
塔臂长度 Tower jib length (m)		45			51			60		
幅度 Radius (m)	主臂角度 Boom angle (°)									
	85	75	65	85	75	65	85	75	65	
20	31.5/21.0									
22	30.8			21.0/23.0						
24	30.1			20.5						
26	29.3			19.8			10.4			
28	28.4			19.3			10.0			
30	26.7			18.8			9.7			
32	26.2			18.3			9.4			
34	24.4			17.8			9.1			
36	22.6	19.2		17.4			8.8			
38	21.0	18.0		17.0			8.5			
40	19.6	16.9		16.6	16.2		8.3			
42	18.3	15.9		16.3	15.3		8.1			
44	17.1	15.0		16.0	14.4		7.9	9.1		
46	16.0	14.1		15.1	13.6		7.7	8.7		
48	15.1	13.3		14.4	12.9		7.4	8.5		
50		12.6		13.5	12.1		7.0	8.3		
52		11.9		12.1	11.5		6.7	8.1		
54		11.3	9.0	11.7	10.8		6.3	7.8		
56		10.7	8.5		10.3	8.0/57.0	6.0	7.6		
58		10.2	8.1		9.7	7.6	5.7	7.4		
60			7.7		9.3	7.1	5.5	7.0		
62			7.3		8.8	6.8	5.2	6.7	5.7	
64			6.9		8.4	6.4	5.0	6.3	5.3	
66			6.6			6.1		6.0	5.0	
68			9.2			5.7		5.7	4.7	
70						5.4		5.5	4.4	
72						5.2		5.3	4.2	
74									3.9	
76									3.7	
78									3.5	
80									3.3	
82									3.2	

塔式副臂工况载荷表 Tower Jib Lifting Load Chart

主臂长度 Boom length (m)		主臂60米 Boom length 60m								
塔臂长度 Tower jib length (m)		27			33			39		
幅度 Radius (m)	主臂角度 Boom angle (°)									
	85	75	65	85	75	65	85	75	65	
16	51.0/16.3									
18	44.8				43.6					
20	39.7				38.6			38.0		
22	35.5				34.5			33.9		
24	32.0				31.1			30.5		
26	29.1				28.2			27.6		
28	26.5				25.7			25.1		
30	24.3	24.2/31.0			23.5			22.9		
32	22.4	23.1			21.6			21.0		
34		21.6			20.0	20.8		19.3		
36		20.2			18.5	19.5		17.8	18.5/36.5	
38		19.0			17.2	18.3		16.5	17.6	
40		17.9				17.3		15.3	16.6	
42		16.8				16.3		14.2	15.7	
44			12.5/45.0			15.3		13.2	14.8	
46			12.0			14.5			14.0	
48			11.4			13.7	10.8/48.5		13.2	
50			10.8				10.2		12.5	
52			10.2				9.7		11.8	
54							9.2		11.2	
56							8.7		8.2	
58							8.3		7.7	
60									7.4	
62									7.0	
64									6.6	

塔式副臂工况载荷表 Tower Jib Lifting Load Chart

主臂长度 Boom length (m)		主臂60米 Boom length 60m								
塔臂长度 Tower jib length (m)		45			51			60		
幅度 Radius (m)	主臂角度 Boom angle (°)									
	85	75	65	85	75	65	85	75	65	
20	31.0/21.5									
22	30.9			21.0/23.3						
24	29.6			20.6						
26	26.7			20.0			10.5			
28	24.3			19.5			10.1			
30	22.1			19.0			9.8			
32	20.3			18.4			9.5			
34	18.6			17.8			9.2			
36	17.1			16.4			8.9			
38	15.8			15.1			8.6			
40	14.6	15.9		13.9			8.3			
42	13.5	15.0		12.8	14.4		8.1			
44	12.5	14.2		11.9	13.6		7.9			
46	11.6	13.4		11.0	12.8		7.7	9.1		
48	10.8	12.7		10.2	12.1		7.5	8.8		
50	10.1	12.0		9.4	11.5		7.1	8.4		
52		11.4		9.0	10.9		6.8	8.2		
54		10.8		8.5	10.3		6.4	8.0		
56		10.2	7.6		9.7		6.1	7.8		
58		9.7	7.2		9.2		5.8	7.6		
60		9.2	6.8		8.7	6.3	5.5	7.3		
62			6.5		8.3	5.9	5.3	6.9		
64			6.1		7.9	5.6	5.1	6.6	4.5	
66			5.8		7.5	5.3		6.3	4.2	
68			5.5			5.0		6.0	4.0	
70			5.2			4.7		5.7	3.7	
72						4.5		5.4	3.5	
74						4.2		5.2	3.3	
76						4.0			3.0	
78									2.8	
80									2.6	
82									2.5	
84									2.5	

载荷表说明：

- 载荷表中额定起重量，指在给定的臂架长度、工作幅度条件下，重物自由悬挂，在坚实、平坦地面作业所能保证的最大起重量。作业者须视各种不良条件（如地面松软或不平、风力、侧面负荷、摆动作用、多台起重机合力起吊）限制或降低起重机的起重量；
- 载荷表中额定起重量包括吊钩、钢丝绳、和其它所有吊具的重量；
- 载荷表中没有列出额定值的空白区，不允许将起重机用于该区所对应的起重作业；
- 载荷表中起重量为带上车全配重和下车全配重的起重量；
- 使用主臂可以配置臂端单滑轮机构，臂端单滑轮机构的起重量为载荷表中相应的额定起重量减去臂端单滑轮机构、12t吊钩和吊具的重量；
- 臂端单滑轮机构的最大起重量（包括吊钩、吊具和起升钢丝绳）不准超过12t，载荷表中的额定起重量小于12t时按载荷表起吊。

Notes on Lifting Load Chart:

- The total rated lifting loads shown in above tables are the max. lifting capacity based on the condition that crane set up on firm and level ground with given boom length, radius and load, crane operator shall limit or reduce lifting loads according to variable working conditions (soft or uneven ground, wind, side loading, slewing action, lifting with one more cranes).
- The total rated lifting loads include the weight of hook block, wire rope and other slings.
- The blank area in above tables means crane operation is not allowed corresponding to these areas.
- The total rated lifting loads are the lifting capacity for the crane with Car-body counterweight and carrier counterweight.
- Boom can be equipped with a boom tip single sheave, which lifting load is the total rated lifting loads in above table decrease the weight of single sheave, 12t capacity hook block and slings.
- The max. rated lifting load for single top is 12t (include the weight of hook block, slings and hoist wire rope), if rated lifting load in above tables is less than 12t, load lifting is according to the table.