

## 800D Product Guide

ASME B30.5 • Imperial 85%



### Features

- 20,87 t (23 USt) rating
- Self-lubricating "Easy Glide" wear pads
- 30,48 m (100 ft) four-section boom
- Internal anti-two block

# NATIONAL CRANE 800D

The 800D delivers 20,87 t (23 USt) maximum capacity, 46,32 m (152 ft) maximum vertical reach and a 33,22 m (109 ft) maximum vertical hydraulic reach with main boom.

## Features

### > Boom tip

The speedy-reeve boom tip and sheave blocks simplify rigging changes. Load line wedge socket removal is not required for reeving of multi-part line options.

### > Four-section boom

At 30,48 m (100 ft) the 800D boom is the longest in its size range. The longer boom allows the operator to perform more lifts without the use of a jib, reducing setup time and improving efficiency.

### > Overload protection

All National Crane boom trucks are equipped with overload protection. A Rated Capacity Limiter (RCL) is required on all machines equipped with jibs or personnel baskets.

### > Optional auger attachment

Available on the 890D only, the 14,000 ft/lb two-speed auger attachment has a maximum digging radius of 39 ft.

### > Color graphical RCL system

Easy to setup and operate color graphical RCL system with enhanced usability and jog dial menu selection. It also includes enhanced troubleshooting features for ease in serviceability, work area definition system and on-board outrigger monitor system.

### > Options and Lift Solutions

- Hydraulic hose reels
- Hydraulic tilting pole grab
- Factory installed tool box options
- Bulkhead and flat-bed options
- One-option hydraulic tool circuit



## Jobsite benefits

- > The stronger standard torsion box improves rigidity, reduces truck frame flex and reduces the need for counterweight.
- > Painting crane components before assembly reduces the possibility of rust, improves serviceability and enhances the appearance of the machine.
- > State of the art control valve provides smoother operation. This design eliminates parts, reducing repair costs and improving the machines serviceability.
- > Sheave bearings on the boom and retract cables can be greased through access holes in the boom side plates and the number of internal boom parts has been reduced to improve serviceability.
- > Burst of Speed winch provides faster winch payout and pickup of unloaded cable.
- > Adjustable swing speed is standard on the 800D. A control knob located on the swing motor brake release valve can be easily adjusted to the crane operator's swing speed preference.
- > Internal anti-two block wire comes standard. It routes the wire through the inside of the boom eliminating the possibility of snagging the wire on obstructions.



**Manitowoc Crane Care when you need it.**  
The assurance of the world's most advanced crane service and support to get you back to work fast.



**Manitowoc Finance helps you get right to work generating profits for your business.**  
Financial tools that help you capitalize on opportunity with solutions that fit your needs.

# Contents

- Dimensions ..... 5
- Mounting configurations ..... 6
- Working range - 851D ..... 8
- Load chart - 851D ..... 9
- Working range - 890D ..... 10
- Load chart - 890D ..... 11
- Working range - 890D with jib ..... 12
- Load chart - 890D with jib ..... 13
- Working range - 8100D ..... 14
- Load chart - 8100D ..... 15
- Working range - 8100D with jib ..... 16
- Load chart - 8100D with jib ..... 17
- Specifications ..... 18
- Symbols glossary ..... 21

# Dimensions

Series	G	Dry weight*	With oil weight*
851D	71 cm (28 in)	6214 kg (13,700 lb)	6448 kg (14,215 lb)
890D	173 cm (68 in)	7468 kg (16,465 lb)	7704 kg (16,985 lb)
8100D	201 cm (79 in)	7797 kg (17,190 lb)	8033 kg (17,710 lb)

\*Above weights do not include subbase, reservoir, front or rear stabilizers, jibs, PTO, pump, bed, boom rests, rear bumper, or any other mounting or crane options.

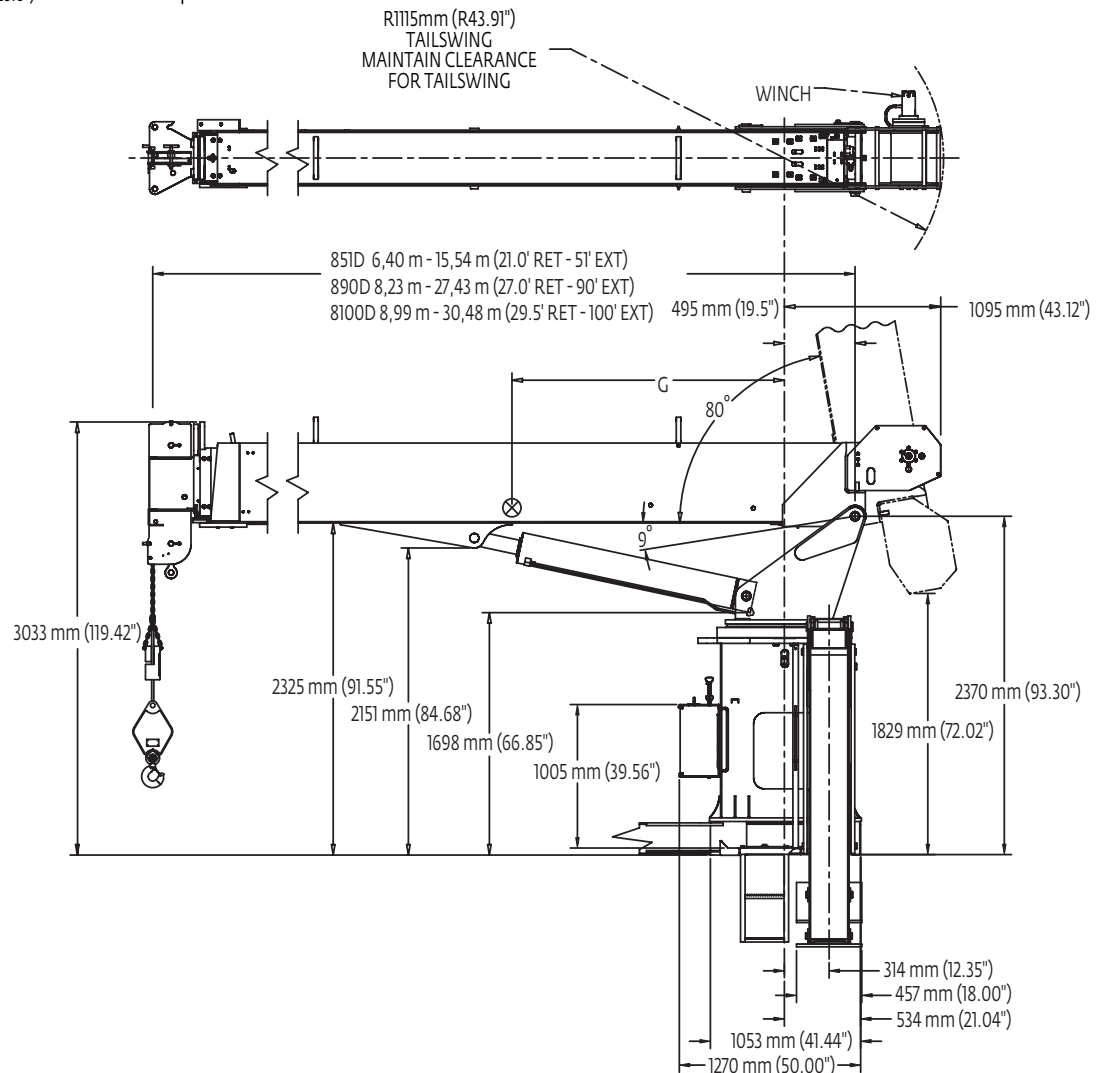
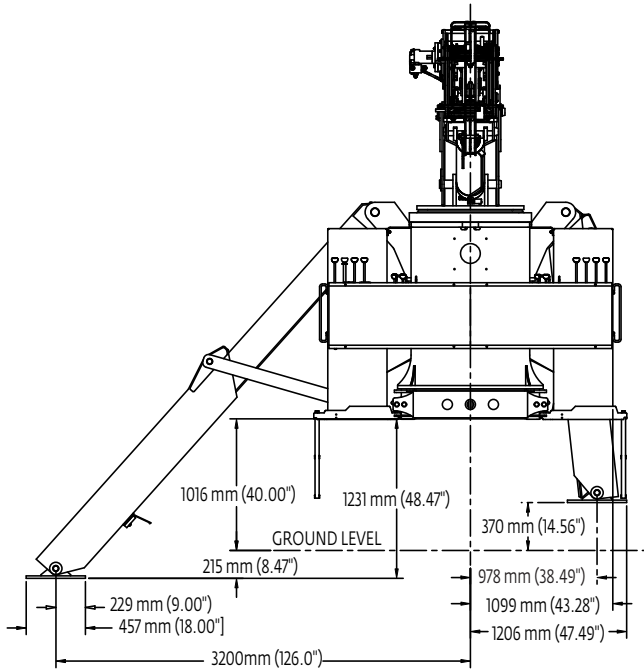

# Mounting configurations

The configurations are based on the 800D with an 85% stability factor. The complete unit must be installed in accordance with factory requirements and a test performed to determine actual stability and counterweight requirements since individual truck chassis vary. Trucks with a frame height in excess of 107 cm (42 in) after mounting will have a final mounted unit height more than 411,5 cm (13 ft 6 in). Chassis that do not meet these minimum stability weights may require counterweight.

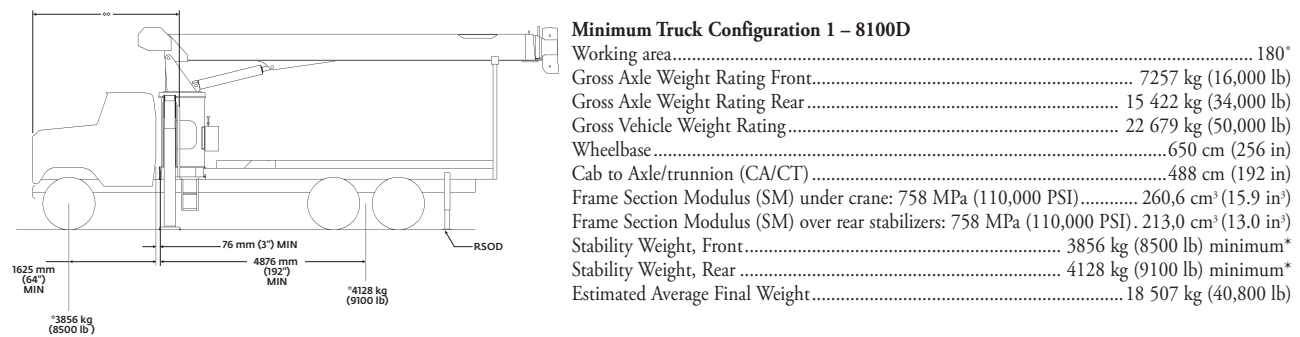

This configuration allows the installation of the 8100D on a chassis by using the subbase for a 6,71 m (22 ft) bed.

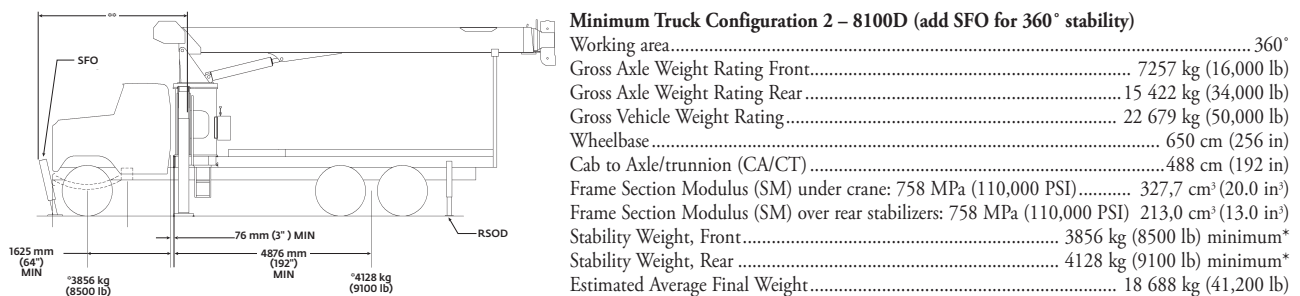

This mount requires front stabilizer for full capacity 360° around the truck. Front stabilizer gives the machine a solid base. This configuration requires a 6,71 m (22 ft) bed for rear overhang, and extended front frame rails for SFO mounting. NOTE: Chassis will require extended front frame rails for SFO mounting.

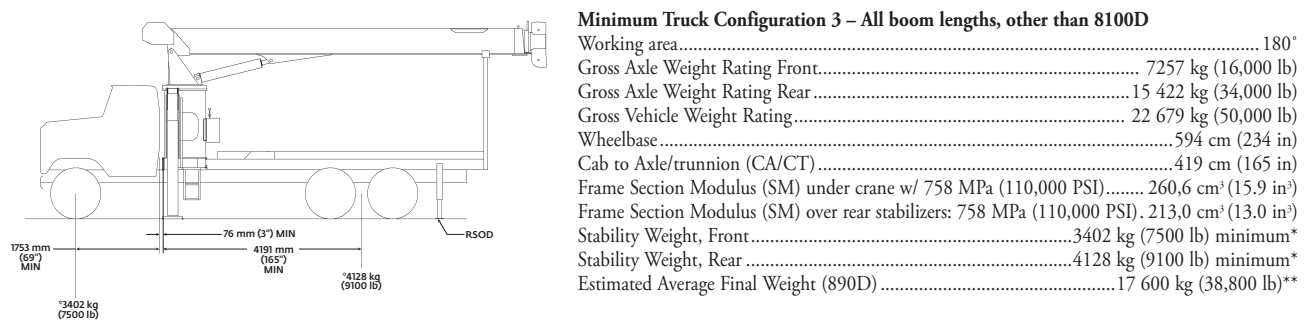

This configuration allows the installation of the 800D on a chassis with a subbase and bed combination which best fits the boom length. Depending on the boom length, the bed can be 18 ft, 20 ft or 22 ft. Not all bed lengths can be used with each boom due to rear overhang limits.



# Mounting configurations

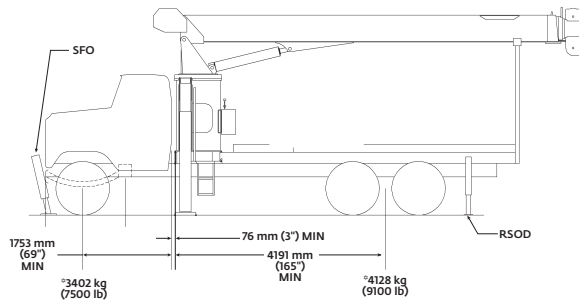

## Minimum Truck Configuration 4 – All boom lengths, other than 8100D

Working area.....	360°
Gross Axle Weight Rating Front.....	7257 kg (16,000 lb)
Gross Axle Weight Rating Rear.....	15 422 kg (34,000 lb)
Gross Vehicle Weight Rating.....	22 679 kg (50,000 lb)
Wheelbase.....	594 cm (234 in)
Cab to Axle/trunnion (CA/CT).....	419 cm (165 in)
Frame Section Modulus (SM) under crane w/ 758 MPa (110,000 PSI).....	327,7 cm <sup>3</sup> (20 in <sup>3</sup> )
Frame Section Modulus (SM) over rear stabilizers: 758 MPa (110,000 PSI)....	213,0 cm <sup>3</sup> (13 in <sup>3</sup> )
Stability Weight, Front.....	3402 kg (7500 lb) minimum*
Stability Weight, Rear.....	4128 kg (9100 lb) minimum*
Estimated Average Final Weight (890D).....	17 780 kg (39,200 lb)

This mount requires front stabilizer for full capacity 360° around the truck. Front stabilizer gives the machine a solid base. Bed length and subbase combinations must match boom length to limit rear overhang. Extended front frame rails required for SFO mounting. NOTE: Chassis will require extended front frame rails for SFO mounting.

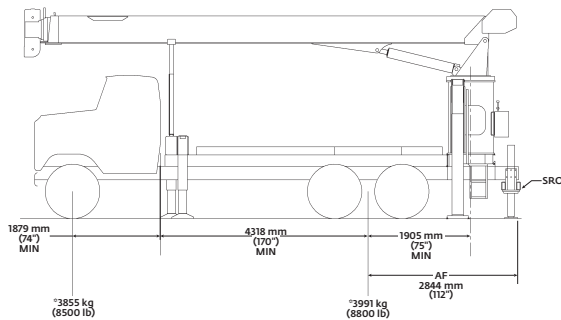

## Minimum Truck Configuration 5 – Rear Mount (all boom lengths)

Working area.....	360°
Gross Axle Weight Rating Front.....	7257 kg (16,000 lb)
Gross Axle Weight Rating Rear.....	18 143 kg (40,000 lb)
Gross Vehicle Weight Rating.....	25 401 kg (56,000 lb)
Wheelbase.....	620 cm (244 in)
Cab to Axle/trunnion (CA/CT).....	432 cm (170 in)
Frame Section Modulus (SM) under crane: 758 MPa (110,000 PSI).....	260 cm <sup>3</sup> (15.9 in <sup>3</sup> )
Stability Weight, Front.....	3856 kg (8500 lb) minimum*
Stability Weight, Rear.....	3991 kg (8800 lb) minimum*
Estimated Average Final Weight (8100D).....	19 504 kg (43,000 lb)

This configuration allows the rear-mount installation of the 800D. This configuration is 360° stable and allows the effective use of close working area to lift the heavier capacity loads. Maximum bed length is 4,87 m (16 ft). Requires single rear outrigger.

### Notes:

- Gross Vehicle Weight rating (GVWR) is dependent on all components of the vehicle (axles, tires, springs, frame, etc.) meeting manufacturers' recommendations; always specify GVWR when purchasing trucks
- Diesel engines require a variable speed governor and energize-to-run fuel solenoid for smooth crane operation; electronic fuel injection requires EET engine remote throttle
- All mounting data is based on a 800D with an 85 percent stability factor
- The complete unit must be installed in accordance with factory requirements, and a test performed to determine actual stability and counterweight requirements per SAE J765; contact the factory for details
- Transmission neutral safety interlock switch is required

\*Estimated axle scale weights prior to installation of crane, stabilizers and subbase for 85% stability.

\*\*If the distance from the front bumper (SFO) to center of rotation exceeds 366 cm (144 in), the 12,19 m (40 ft) overall truck length restriction will be exceeded. Overall length restrictions vary from state to state. In some states it is legal to be more than 12,18 m (40 ft) in length, and some states allow overlength permits.

# Working range - 851D

 15,5 m  
(51 ft)

 100%  
6,4 m  
(21 ft)

 360°

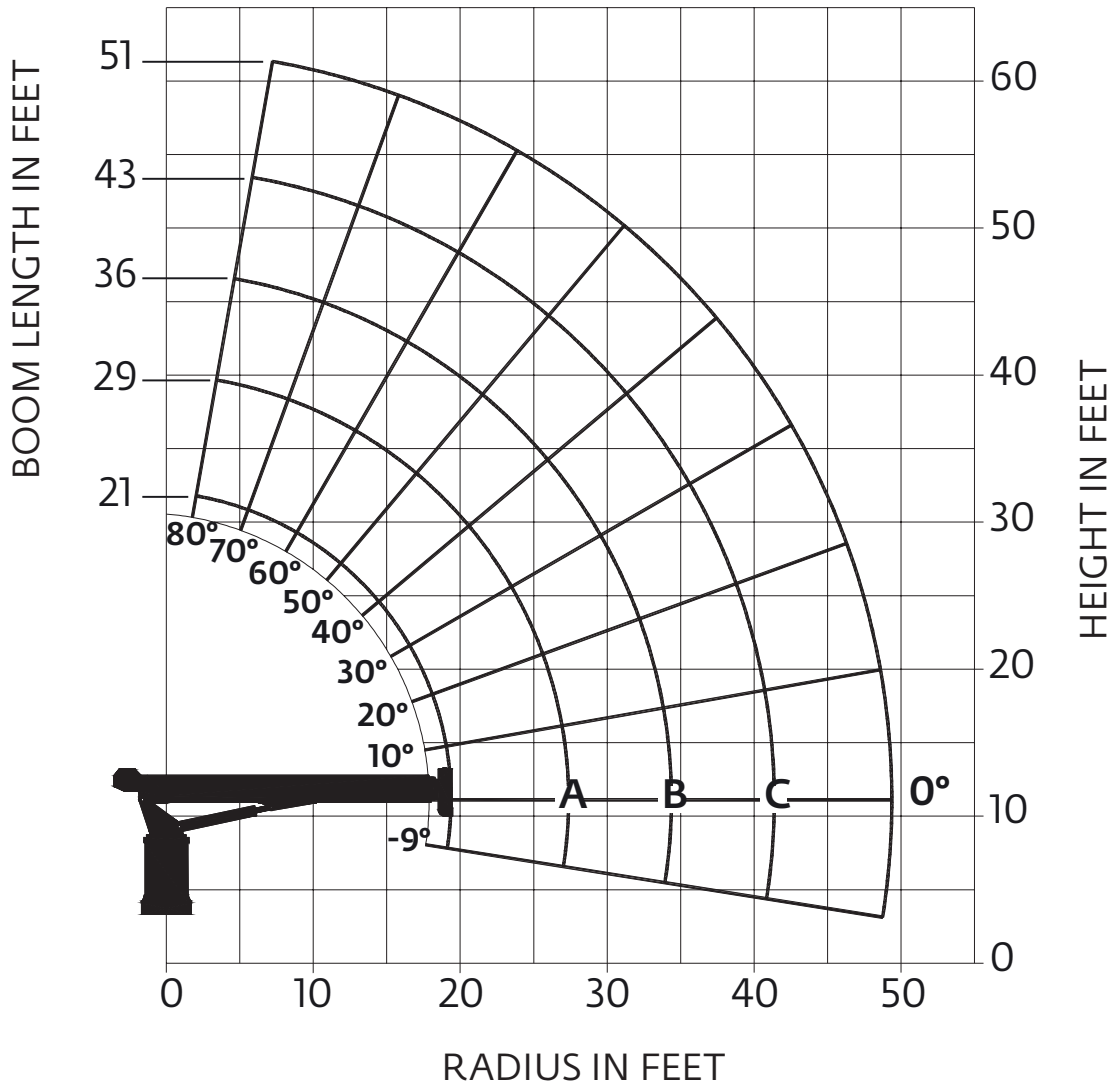

THIS CHART IS ONLY A GUIDE AND SHOULD NOT BE USED TO OPERATE THE CRANE.

The individual crane's load chart, operating instructions and other instructional plates must be read and understood prior to operating the crane.



# Load chart - 851D



6,4 m - 15,5 m  
(21 ft - 51 ft)



100%  
6,4 m  
(21 ft)



360°



Pounds

LOAD RADIUS (FEET)	LOADED BOOM ANGLE	21 ft BOOM (lb)	LOADED BOOM ANGLE	A 29 ft BOOM (lb)	LOADED BOOM ANGLE	B 36 ft BOOM (lb)	LOADED BOOM ANGLE	C 43 ft BOOM (lb)	LOADED BOOM ANGLE	51 ft BOOM (lb)
5	73.5	46,000								
8	64	32,800	72	30,500	76	29,000				
10	57.5	27,800	67.5	26,200	72.5	25,100	76	23,800	78	22,500
12	50.5	24,500	63	23,200	69	22,100	73	21,100	76	21,000
14	42.5	21,400	58.5	20,500	65.5	20,000	70	18,800	73.5	18,000
16	33	18,400	53.5	18,300	62	17,500	67	16,600	71	16,500
20			42.5	15,500	54	15,100	61	14,000	66	13,500
25			23	11,400	43	12,500	53	12,000	59.5	11,000
30					29	9300	43.5	10,000	53	9600
35							33	7800	46	8500
40							16	6000	37	6800
45									25	5800
	0	11,200	0	7200	0	5400	0	4200	0	3200

**NOTE:**

1. All capacities are in pounds, angles in degrees, radius in feet.
2. Loaded boom angles are given as reference only.

*THIS CHART IS ONLY A GUIDE AND SHOULD NOT BE USED TO OPERATE THE CRANE.*

*The individual crane's load chart, operating instructions and other instructional plates must be read and understood prior to operating the crane.*

# Working range - 890D

 27,43 m  
(90 ft)

 100%  
6,4 m  
(21 ft)

 360°

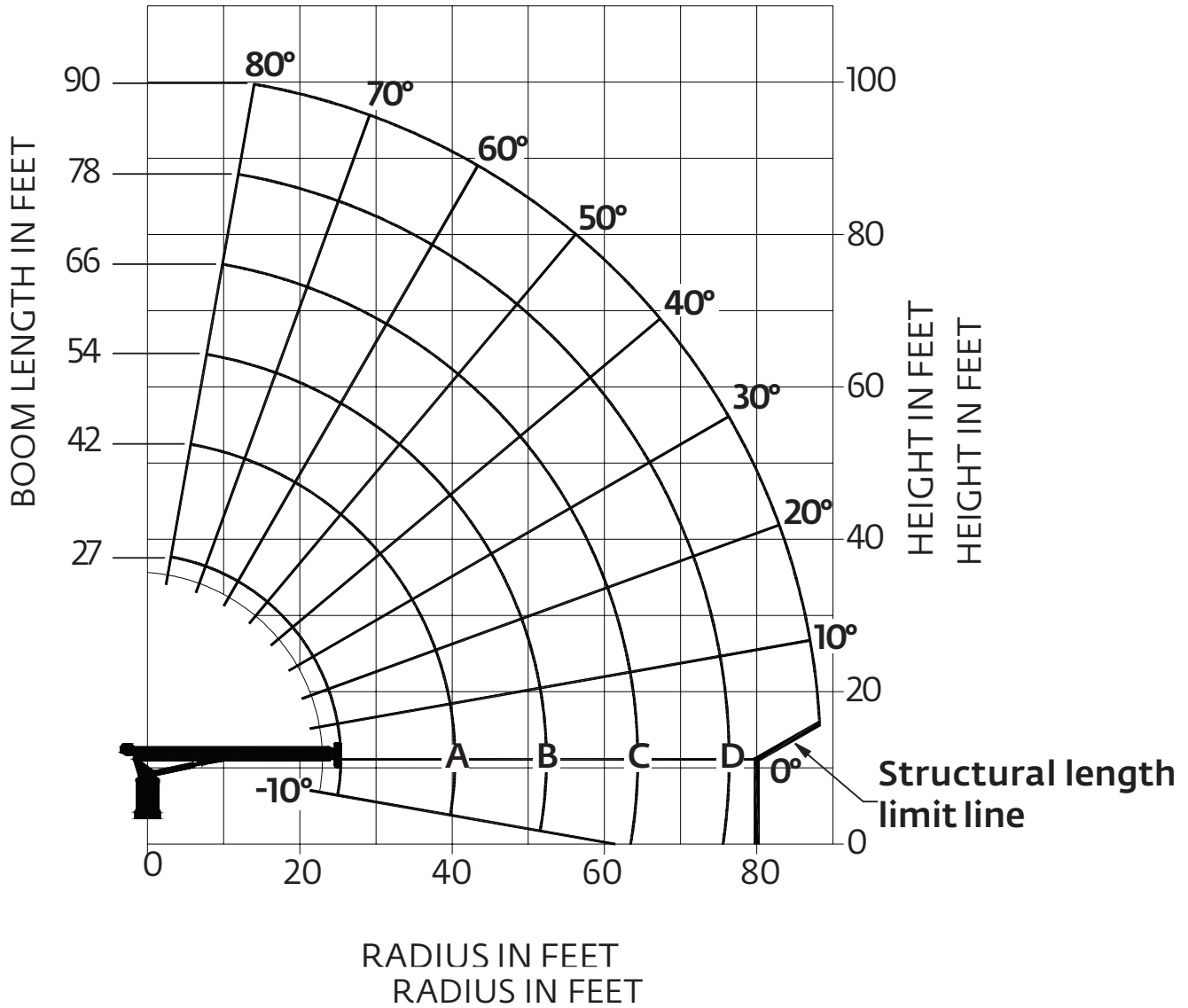

THIS CHART IS ONLY A GUIDE AND SHOULD NOT BE USED TO OPERATE THE CRANE.

The individual crane's load chart, operating instructions and other instructional plates must be read and understood prior to operating the crane.

# Load chart - 890D



8,23 m - 27,43 m  
(27 ft - 90 ft)



100%  
6,4 m  
(21 ft)



360°



Pounds

LOAD RADIUS (ft)	LOADED BOOM ANGLE	27 ft BOOM (lb)	LOADED BOOM ANGLE	A 42 ft BOOM (lb)	LOADED BOOM ANGLE	B 54 ft BOOM (lb)	LOADED BOOM ANGLE	C 66 ft BOOM (lb)	LOADED BOOM ANGLE	D 78 ft BOOM (lb)	LOADED BOOM ANGLE	90 ft BOOM (lb)
5	77	46,000										
8	70	33,000										
10	65	27,400	75.5	23,900	79	22,300						
12	60	23,500	72.5	20,900	77	19,100						
14	54.5	20,700	69.5	18,300	75	16,800	78	15,400				
16	49	18,300	66.5	16,300	72.5	14,800	76	13,600	79	12,600		
20	35	14,500	60	13,200	68	12,200	72.5	11,250	76	10,300	78	10,000
25			51.5	10,700	62	9900	68	9150	72	8450	74.5	8100
30			42	8800	55.5	8350	63.5	7450	68	6800	71.5	6500
35			31	7050	49	6900	58	6400	64	5850	68	5550
40					41	5850	53	5500	60	5250	64.5	4750
45					32	4900	47	4750	55	4400	61	4150
50					18.5	3700	40.5	4050	50.5	3850	57	3600
55							32.5	3350	45.5	3300	53	3150
60							22.5	2700	39.5	2900	49	2750
65									33	2450	44	2400
70									25	1950	39	2050
75									12	1150	33.5	1700
80											26.5	1350
85											17	850
	0	7400	0	3500	0	2000	0	950				

**NOTE:**

1. All capacities are in pounds, angles in degrees, radius in feet.
2. Loaded boom angles are given as reference only.

THIS CHART IS ONLY A GUIDE AND SHOULD NOT BE USED TO OPERATE THE CRANE.

The individual crane's load chart, operating instructions and other instructional plates must be read and understood prior to operating the crane.

# Load charts - 890D with jib

 27,43 m  
(90 ft)

 100%  
6,4 m  
(21 ft)

 360°

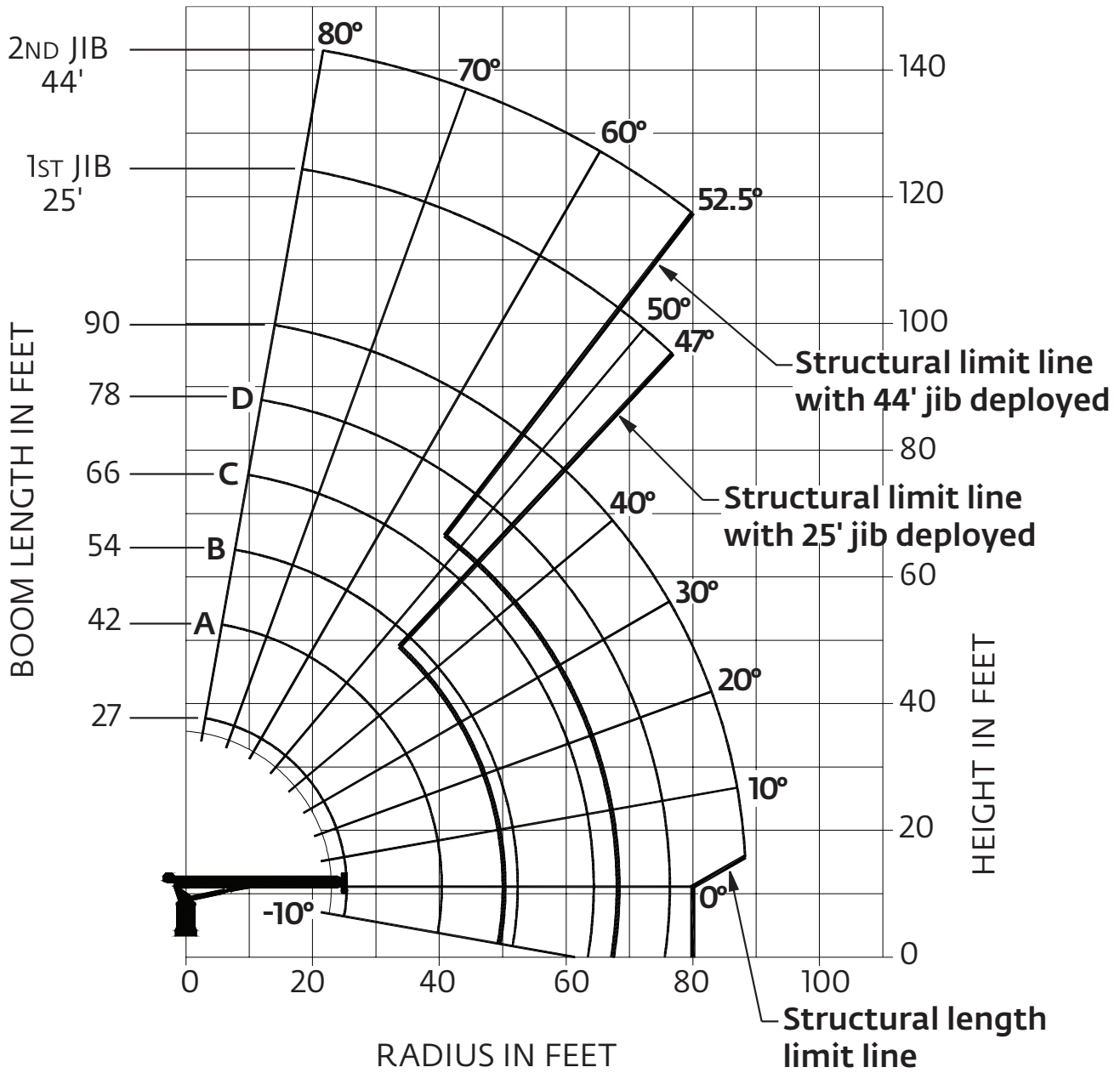

THIS CHART IS ONLY A GUIDE AND SHOULD NOT BE USED TO OPERATE THE CRANE.

The individual crane's load chart, operating instructions and other instructional plates must be read and understood prior to operating the crane.

# Load charts - 890D with jib



8,23 m - 27,43 m  
(27 ft - 90 ft)



100%  
6,4 m  
(21 ft)



360°



Pounds

LOAD RADIUS (ft)	LOADED BOOM ANGLE	27 ft BOOM (lb)	LOADED BOOM ANGLE	A 42 ft BOOM (lb)	LOADED BOOM ANGLE	B 54 ft BOOM (lb)	LOADED BOOM ANGLE	C 66 ft BOOM (lb)	LOADED BOOM ANGLE	D 78 ft BOOM (lb)	LOADED BOOM ANGLE	90 ft BOOM (lb)	LOAD RADIUS (ft)	LOADED BOOM ANGLE	25 ft JIB (lb)	LOADED BOOM ANGLE	44 ft JIB (lb)
5	77	46,000											30	76.5	4800	79	3100
8	70	32,300											35	74	4300	77	2900
10	65	26,700	75.5	23,400	79	21,900							40	71.5	3650	75	2700
12	60	22,800	72.5	20,400	77	18,700							45	68.5	3000	73	2500
14	54.5	19,900	69.5	17,800	75	16,400	78	15,050					50	66	2450	71	2300
16	49	17,500	66.5	15,800	72.5	14,400	76	13,250	79	12,300			55	63	2000	69	2100
20	35	13,700	60	12,700	68	11,800	72.5	10,900	76	10,000	78	9750	60	60	1600	66	1800
25			51.5	10,200	62	9500	68	8800	72	8150	74.5	7850	65	57	1300	63.5	1500
30			42	8300	55.5	7950	63.5	7100	68	6500	71.5	6250	70	54	1000	61	1250
35			31	6550	49	6500	58	6050	64	5550	68	5300	75	50.5	750	58.5	1050
40					41	5450	53	5150	60	4950	64.5	4500	80	47	500	55.5	850
45					32	4500	47	4400	55	4100	61	3900	85			52.5	650
50					18.5	3300	40.5	3700	50.5	3550	57	3350					
55							32.5	3000	45.5	3000	53	2900					
60							22.5	2350	39.5	2600	49	2500					
65									33	2150	44	2150					
70									25	1650	39	1800					
75									12	850	33.5	1450					
80											26.5	1100					
85											17	600					
	0	6600	0	3000	0	1600	0	600									
ADD TO CAPACITIES WHEN NO JIB STOWED (lb)		800		500		400		350		300		250					

**NOTE:**

1. All capacities are in pounds, angles in degrees, radius in feet.
2. Loaded boom angles are given as reference only.

THIS CHART IS ONLY A GUIDE AND SHOULD NOT BE USED TO OPERATE THE CRANE.

The individual crane's load chart, operating instructions and other instructional plates must be read and understood prior to operating the crane.

# Working range - 8100D

 30,48 m  
(100 ft)

 100%  
6,4 m  
(21 ft)

 360°

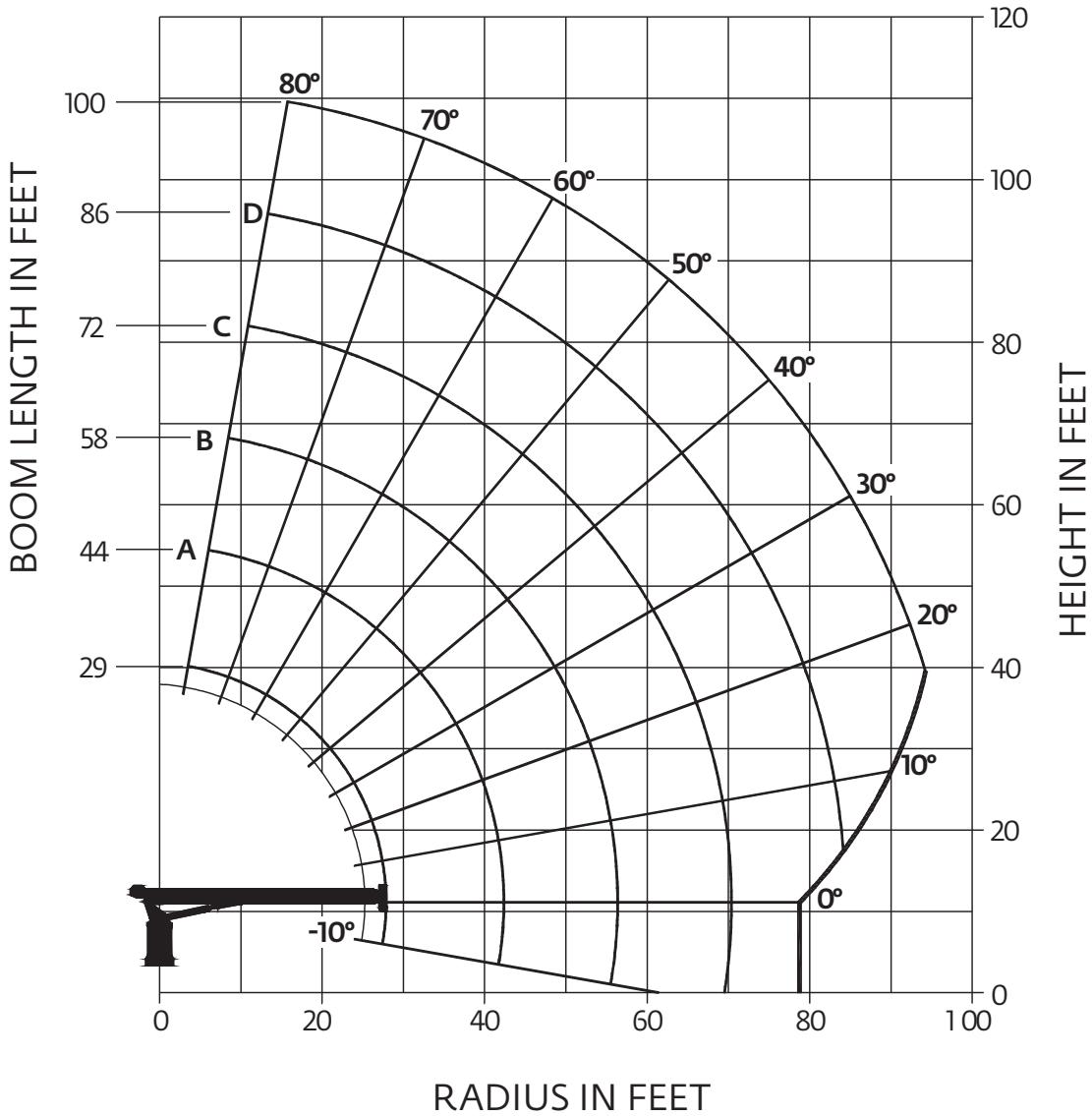

THIS CHART IS ONLY A GUIDE AND SHOULD NOT BE USED TO OPERATE THE CRANE.

The individual crane's load chart, operating instructions and other instructional plates must be read and understood prior to operating the crane.

# Load chart - 8100D



8,99 m - 30,48 m  
(29.5 ft - 100 ft)



100%  
6,4 m  
(21 ft)



360°



Pounds

LOAD RADIUS (FEET)	LOADED BOOM ANGLE	29 ft BOOM (lb)	LOADED BOOM ANGLE	A 44 ft BOOM (lb)	LOADED BOOM ANGLE	B 58 ft BOOM (lb)	LOADED BOOM ANGLE	C 72 ft BOOM (lb)	LOADED BOOM ANGLE	D 86 ft BOOM (lb)	LOADED BOOM ANGLE	100 ft BOOM (lb)
5	79	46,000										
8	72.5	31,500	79	28,500								
10	68	26,300	76	23,800								
12	63.5	22,600	73.5	20,300	78	18,500						
14	59	19,800	70.5	17,800	76	16,200	79.5	14,700				
16	54	17,500	68	15,800	74	14,300	77.5	13,000				
20	43	14,200	61	12,800	69.5	11,700	74.5	10,700	77.5	9850		
25	25	10,500	54	10,300	64	9400	70	8600	74	7950	77	7350
30			45	8500	58.5	7800	66	7000	70.5	6450	74	6100
35			35	6900	53	6550	61.5	5950	67	5500	71	5150
40			20	5200	46	5550	56.5	5100	63	4700	67.5	4500
45					38	4700	51.5	4400	59.5	4100	64.5	3900
50					28.5	3850	46	3800	55	3550	61	3400
55					14	2650	40	3250	51	3100	57.5	2900
60							33	2700	46.5	2700	54	2550
65							24	2150	41	2300	50	2100
70							6.5	1050	35.5	1900	46	1900
75									29	1550	42	1600
80									20	1100	37	1300
85											32	1050
90											25	750
	0	5900	0	2900	0	1400	0	500				

**NOTE:**

1. All capacities are in pounds, angles in degrees, radius in feet.
2. Loaded boom angles are given as reference only.

*THIS CHART IS ONLY A GUIDE AND SHOULD NOT BE USED TO OPERATE THE CRANE.*

*The individual crane's load chart, operating instructions and other instructional plates must be read and understood prior to operating the crane.*



# Working range - 8100D with jib

 30,48 m  
(100 ft)

 100%  
6,4 m  
(21 ft)

 360°

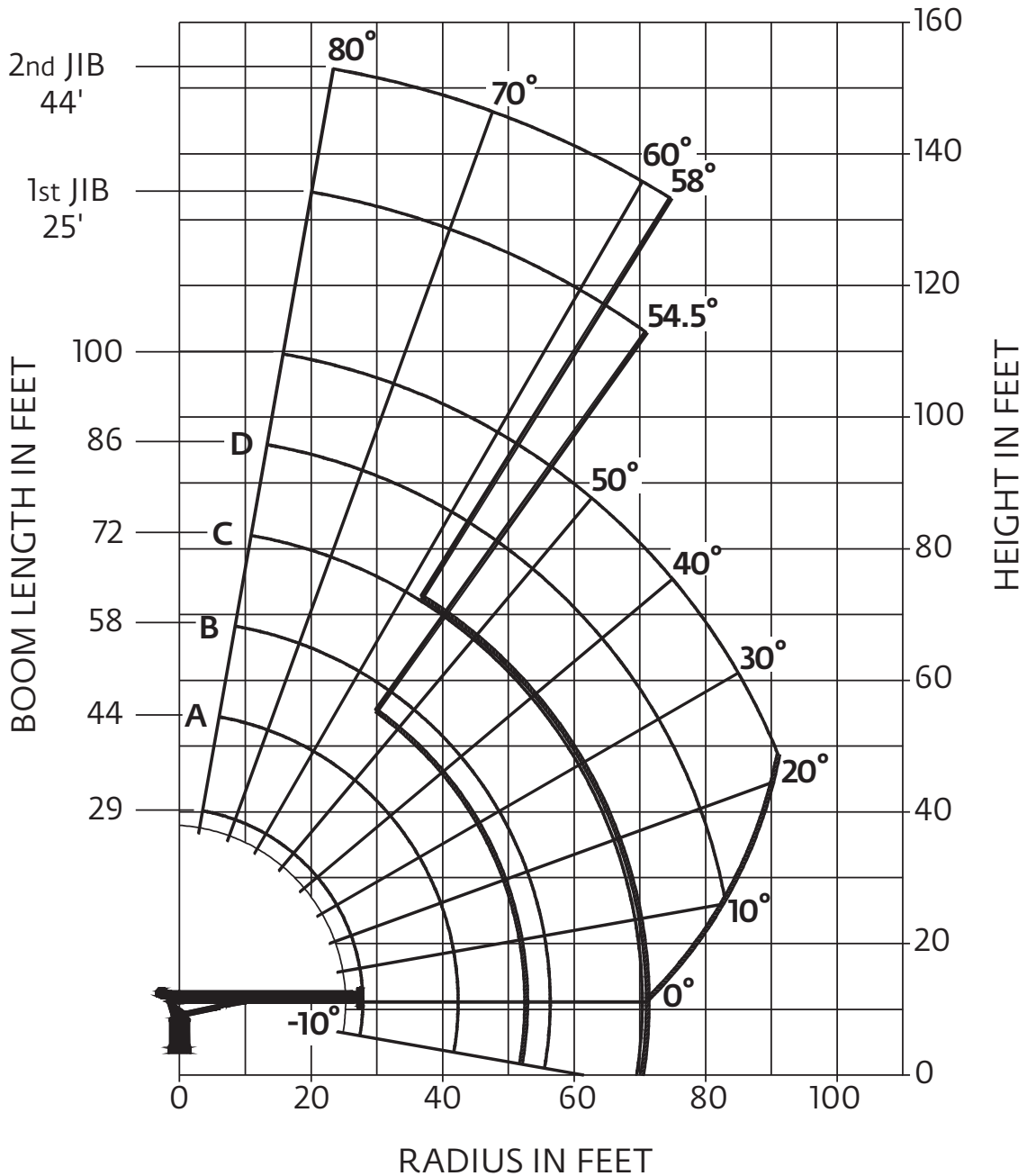

THIS CHART IS ONLY A GUIDE AND SHOULD NOT BE USED TO OPERATE THE CRANE.

The individual crane's load chart, operating instructions and other instructional plates must be read and understood prior to operating the crane.

# Load chart - 8100D with jib



8,99 m - 30,48 m  
(29.5 ft - 100 ft)



100%  
6,4 m  
(21 ft)



360°



Pounds

LOAD RADIUS (FEET)	LOADED BOOM ANGLE	29 ft BOOM (lb)	LOADED BOOM ANGLE	A 44 ft BOOM (lb)	LOADED BOOM ANGLE	B 58 ft BOOM (lb)	LOADED BOOM ANGLE	C 72 ft BOOM (lb)	LOADED BOOM ANGLE	D 86 ft BOOM (lb)	LOADED BOOM ANGLE	100 ft BOOM (lb)	LOAD RADIUS (FEET)	LOADED BOOM ANGLE	25 ft JIB (lb)	LOADED BOOM ANGLE	44 ft JIB (lb)
5	79	46,000											30	78	3900	80	2750
8	72.5	30,700	79	27,900									35	75.5	3400	78	2500
10	68	25,500	76	23,200									40	73	2800	76	2250
12	63.5	21,800	73.5	19,700	78	18,050							45	70.5	2350	74	2000
14	59	19,000	70.5	17,200	76	15,750	79.5	14,350					50	68	1850	72	1850
16	54	16,700	68	15,200	74	13,850	77.5	12,650					55	65	1500	70	1600
20	43	13,400	61	12,200	69.5	11,250	74.5	10,350	77.5	9550	80	7450	60	62.5	1300	67.5	1350
25	25	9700	54	9700	64	8950	70	8250	74	7650	77	7100	65	60	1100	65	1050
30			45	7900	58.5	7350	66	6650	70.5	6150	74	5850	70	57	750	63	950
35			35	6300	53	6100	61.5	5600	67	5200	71	4900	75	54.5	600	60.5	800
40			20	4600	46	5100	56.5	4750	63	4400	67.5	4250	80			58	600
45					38	4250	51.5	4050	59.5	3800	64.5	3650					
50					28.5	3400	46	3450	55	3250	61	3150					
55					14	2200	40	2900	51	2800	57.5	2650					
60							33	2350	46.5	2400	54	2300					
65							24	1800	41	2000	50	1850					
70							6.5	700	35.5	1600	46	1650					
75									29	1250	42	1350					
80									20	800	37	1050					
85											32	800					
90											25	500					
	0	5100	0	2300	0	950											

**NOTE:**

1. All capacities are in pounds, angles in degrees, radius in feet.
2. Loaded boom angles are given as reference only.

THIS CHART IS ONLY A GUIDE AND SHOULD NOT BE USED TO OPERATE THE CRANE.

The individual crane's load chart, operating instructions and other instructional plates must be read and understood prior to operating the crane.

# Specifications

## Super Structure

### Boom

Three boom length options:

- 21 ft – 51 ft (6,4 m – 15,5 m) three-section with a max. tip height of 62 ft (18,9 m)
- 27 ft – 90 ft (8,23 m – 27,43 m), four-section with a max tip height of 100 ft (30,48 m)
- 29.5 ft – 100 ft (8,99 m – 30,48 m), four-section with a max tip height of 110 ft (33,53 m)

Proportional extension via multi-stage hydraulic cylinder and cable operation; four-plate, high-strength steel construction; two-sheave, quick reeve boom nose and Easy-glide wear pads.

### Boom elevation

One (1) double-acting, hydraulic cylinder with holding valve with a range of  $-10^{\circ}$  to  $+80^{\circ}$

### Rated Capacity Limiting (RCL) and anti-two block (ATB) systems

Graphical Rated Capacity Limiter and anti-two block system with audio visual warning and crane function lockout. Includes 109 mm (4.3 in), color screen for real-time display of boom angle, length, radius, tip height, maximum permissible load, load indication and warning of impending overload or anti-two-block condition. Work Area Definition System (WADS) allowing operator definable non-lockout warning limits for crane operations and CAN bus sensors. Any function that will increase the load radius plus winch up of load is interrupted when maximum capacity is exceeded. A momentary override key switch for emergency repositioning of boom. Audio visual warning and crane function lockout. Hard-wired ATB circuit routed internally to the boom.

### Operator station

Dual-station ASME B30.5 compliant proportional crane controls with mechanical direct-to-valve control of hoist, lift, telescope and swing functions on both the driver and passenger sides of the crane. Mechanical direct-to-valve controls of all outrigger functions on both the driver and passenger sides of the crane. Burst of speed hoist switch located at each hoist control lever. Sealed electric switches for control of engine start/stop and horn. Throttle pedal located at each side. Load chart(s) located at each station.

### Slewing

One (1) Planetary slewing gear with a low speed high torque motor. Integrated holding valves and spring applied, pressure released brake release circuit;  $375^{\circ}$ , non-continuous rotation; manually adjustable swing speed needle valve.

### Hydraulic system

Open-center hydraulics system allowing for multifunction operation of all crane functions. One (1) three section gear pump for all functions and optimized system performance.

Shaft input of 2400 RPM generating:

Section #1 (Boom/Telescope/Outriggers): 18 gpm (68 lpm) max flow

Section #2 (Hoist): 34 gpm (128.7 lpm) max flow

Section #3 (Swing): 10 gpm (37.9 lpm) max flow

65 gallon (246 L) hydraulic reservoir with SAE o-ring connections and integrated suction shut-off ball valve for easy maintenance and SAE o-ring hydraulic fittings and hoses.

### Electrical system

Automotive grade, fully wire harnessed 12VDC electrical system using sealed connectors

*\*Denotes optional equipment.*

## Lower



### Chassis Mounting

Torsion resistant, high-strength steel sub-frame. Crane frame and sub-frame attached using threaded mounting bolts and drilled and bolted clamp plates for secure attachment to the truck chassis. Rear outriggers attached using bolts to truck frame and subframe to ensure a secure attachment. Rear bumper underride protection standard on factory mounted cranes.



### Mounting configurations

**Standard Mount:** Crane frame located behind the truck cab; Crane frame supported by a torsion resistant sub-frame; Subframe designed for a 20 ft (6,1 m) flatbed; A-frame style front outriggers at the crane frame; Out and Down style rear outriggers; Full span outriggers load chart operation; Boom stows over rear of truck; Removable boom rest fabricated from structural steel, located at the rear of the flatbed

**Rear Mount:** Crane frame located at the rear of the truck chassis; Crane frame supported by a torsion resistant subframe; Subframe designed for a 16 ft (4,88 m) flatbed; Out and Down style over-frame outriggers at the crane frame; Out and Down style over-frame outriggers behind truck cab; Single rear stabilizer at rear of crane frame; Full span outriggers load chart operation; Boom stows over rear of truck; Fixed boom rest fabricated from structural steel, located on the top of the front outrigger box

**Tractor Mount:** Crane frame located behind the truck cab on a short wheelbase, fifth wheel equipped truck; Crane frame supported by a torsion resistant sub-frame; Out and Down style front outriggers at the crane frame; Out and Down style rear outriggers at the crane frame; Full span outriggers load chart operation; Boom stows over rear of truck; Fixed boom rest fabricated from structural steel, located behind the truck cab



### Outriggers

Outrigger monitoring system for beam extension standard. Inverted cylinder rods for outrigger jack cylinders to best protection of chromed rod

## Optional items

### • Outriggers, Sub-frame and Flatbed

- > Single Front Outrigger (SFO)
- > 22 ft (6,7 m) subframe and flatbed for a standard mount
- > Wood, steel and super-duty wood or steel flatbeds

### • Hook blocks

- > 7 ton (6,35 mt) Overhaul ball for single part line operation
- > Single sheave, 12,5 ton (11,3 mt) hook block for 2-3 part reeving
- > Two sheave, 22 ton (19,9 mt) hook block for 4-5 part reeving (includes auxiliary lineblock and pendant link)
- > Three sheave, 30 ton (27,2 mt) quick-reeve hook block for 6-part reeving (includes auxiliary lineblock and pendant link)

### • Jib

- > 25 ft – 44 ft (7,6 m – 13,4 m) telescopic jib with manual pull out section
- > Maximum tip height of 143 ft (43,58 m) with 90 ft boom option
- > Maximum tip height of 153 ft (46,63 m) with 100 ft boom option

### • Hydraulics

- > Oil cooler option for duty-cycle operation
- > 1-option control circuit including valve and control lever

### • Operator Aids

- > Hydraulic Capacity Alert System (HCAS) in lieu of RCL
- > Four-function wireless radio remote control
- > Metric capacity charts
- > Spanish documentation and decals
- > External ATB cable routing
- Note: available for the 90ft (27,43m) boom only

### • Personnel platforms

- > One (1) or two (2) person steel, non-insulated, gravity hung, platform options
- > Capacities up to 1200 lbs (544,3 kg) on main boom and 600 lb (226,7 kg) on jib
- > Basket test weight sets available for each
- > BSA-1, BSA-R1 (provides rotation), or BSAY-2 (yoke style)

### • Bulkhead

- > Steel 762 mm (30 in) solid wall bulkhead

*\*Denotes optional equipment.*

# Specifications



## Hoist

10,200 lb (4627 kg) planetary gear with a single speed motor;  
Integrated motor manifold and spring applied, pressure released brake

Parts of Line	1 part line	2 part line	3 part line	4 part line	5 part line	6 part line
Max. boom length to allow hook block to ground level	30,5 m (100 ft)	22,0 m (72 ft)	16,5 m (54 ft)	13,4 m (44 ft)	8,8 m (29 ft)	8,8 m (29 ft)
Linepull and speed	3493 kg (7700 lb)	6985 kg (15,400 lb)	10 478 kg (23,100 lb)	13 971 kg (30,800 lb)	17 463 kg (38,500 lb)	10 865 kg (46,000 lb)
	30 m/min (100 fpm)	15 m/min (50 fpm)	10 m/min (33 fpm)	8 m/min (25 fpm)	6 m/min (20 fpm)	3 m/min (16 fpm)

NOTE: All hoist lifts and speeds in this chart are shown on the fourth layer. Hoist lifts would increase on the lower layers and hoist speeds would increase on the higher layers.

Line Pulls and Reeving Information			
Hoists	Cable specs.	Permissible line pulls	Nominal cable length
Main	Standard 9/16" diameter rotation resistant Min. Breaking Strength 17 463 kg (38,500 lb)	3493 kg (7700 lb)	99,1 m (325 ft)

The approximate weight of 9/16 in wire rope is 1,04 kg/m (0.70 lb/ft).

\*With certain boom and hoist tackle combinations, the allowable line pull may be limited by hoist performance. Refer to Hoist Performance table for lift planning to ensure adequate hoist performance on drum rope layer required.

Hoist Performance			
Wire rope layer	Hoist Line Pull	Line speed	Drum Capacity
1	4627 kg (10,200 lb)	33,8 m /min (111 ft/min)	19,5 m (64 ft)
2	4173 kg (9200 lb)	37,5 m /min (123 ft/min)	41,5 m (136 ft)
3	3811 kg (8400 lb)	41,2 m /min (135 ft/min)	65,5 m (215 ft)
4	3493 kg (7700 lb)	44,8 m /min (147 ft/min)	91,7 m (301 ft)
5	3221 kg (7100 lb)	48,5 m /min (159 ft/min)	120,1 m (394 ft)

\*Refer to Line Pulls and Reeving Information table for max. lifting capacity of wire rope.

Synthetic rope layer height may vary and may reduce available line pull per layer.



































Weight Reductions for Load Handling Devices	
Hook blocks and headache balls	
6,35 t (7 USt), overhaul ball	77,6 kg (171 lb)+
11,3 t (12.5 USt) single-sheave hook block	85 kg (187 lb)+
19,9 t (22 USt) two-sheave hook block	161 kg (355 lb)+
27,2 t (30 USt) three-sheave hook block	261 kg (575 lb)+

+ Refer to rating plate for actual weight

When lifting over boom extension, deduct total weight of all load handling devices reeved over main boom nose directly from boom extension capacity.

NOTE: All load handling devices and boom attachments are considered part of the load and suitable allowances MUST BE MADE for their combined weights. Weights are for Manitowoc furnished equipment.

# Symbols glossary

 Axles	 Drive	 Heavy duty jib	 Radius
 Boom	 Electrical system	 Hoist	 Rotation
 Boom elevation	 Engine	 Hookblock	 Speed
 Boom extension	 Extension	 Hydraulic system	 Steering
 Boom length	 Frame	 Insert	 Suspension
 Boom nose	 Fuel tank capacity	 Lights	 Swing
 Brakes	 Gear	 Oil	 Tires
 Operators station	 Grade	 Outrigger controls	 Transmission
 Counterweight	 Height (no max)	 Outriggers	

# Notes





## Manitowoc Cranes

### Regional headquarters

#### Americas

**Manitowoc, Wisconsin, USA**

Tel: +1 920 684 4410

Fax: +1 920 652 9778

**Shady Grove, Pennsylvania, USA**

Tel: +1 717 597 8121

Fax: +1 717 597 4062

#### Europe and Africa

**Dardilly, France - TOWERS**

Tel: +33 (0)4 72 18 20 20

Fax: +33 (0)4 72 18 20 00

**Wilhelmshaven, Germany - MOBILE**

Tel: +49 (0) 4421 294 0

Fax: +49 (0) 4421 294 4301

#### China

**Shanghai, China**

Tel: +86 21 6457 0066

Fax: +86 21 6457 4955

#### Middle East and Greater Asia-Pacific

**Singapore**

Tel: +65 6264 1188

Fax: +65 6862 4040

**Dubai, UAE**

Tel: +971 4 8862677

Fax: +971 4 8862678/79



This document is non-contractual. Constant improvement and engineering progress make it necessary that we reserve the right to make specification, equipment, and price changes without notice. Illustrations shown may include optional equipment and accessories and may not include all standard equipment.