

SUMITOMO SC 1200

Note: We are constantly improving our products and therefore reserve the right to change designs and specifications without notice.
Units in this specification are shown under International System of Units; the figures in parenthesis are under Gravitational System of Units as old one.

SUMITOMO



PAX Series

SC 1200

120-M ton Hydraulic Crawler Crane & Cable Excavator



Certificate No. 45125

Certificate No. 45125

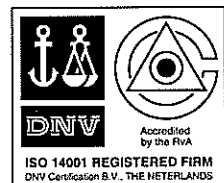

Certificate No. EMSC-1242

Technical Data

General Dimensions:

(in mm)

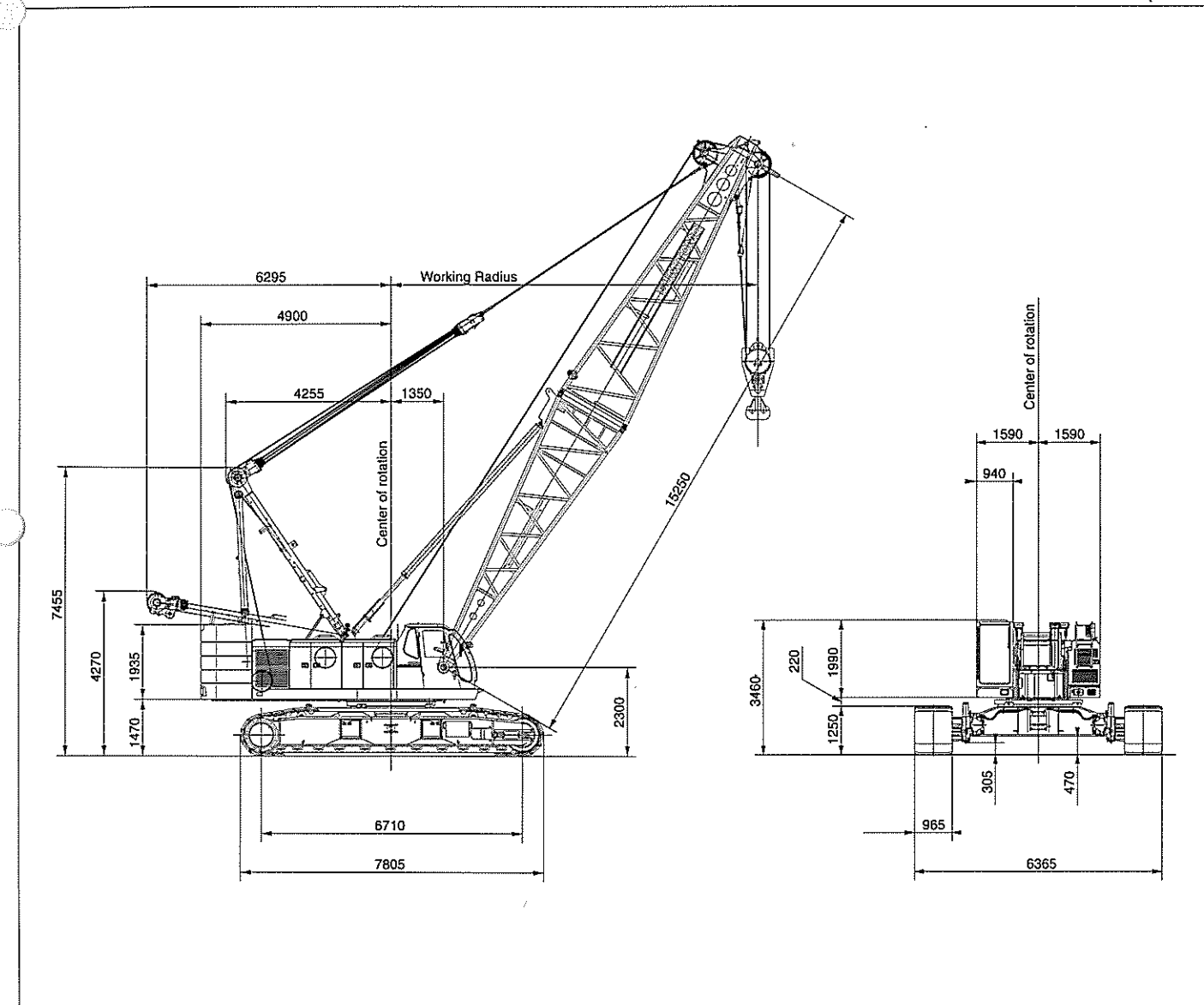

SUMITOMO HEAVY INDUSTRIES CONSTRUCTION CRANE CO., LTD.

5-9-11, Kita-shinagawa, Shinagawa-ku, Tokyo 141-8686, Japan
Phone: 81-3-5421-8586
Facsimile: 81-3-5798-4264

Address Inquires to:

Specifications

SUMITOMO

SC 1200

Basic Machine

Superstructure

UPPER REVOLVING FRAME:

All-welded, precision machined, robust construction. A machined surface provided for mounting load hoist and boom hoist assemblies, and mounting itself on turntable bearing.

TURNTABLE BEARING WITH INTERNAL SWING GEAR:

Single shear ball type; inner race of turntable bearing with integral, internal swing (ring) gear bolted to carbody frame, and outer race of turntable bearing bolted to upper revolving frame.

CONTROL SYSTEM:

System contains one set each of duplicate and triplicate tandem valves which direct oil to various machine function and are actuated by control levers via remote controlled hydraulic servo for all motions. Working speeds can be precisely controlled by motorcycle type throttle and pilot-operated arm chair single axis control levers in cooperation with SUMITOMO's patented "SC" controller that varies engine rpm and hyd. pump discharge simultaneously, or varies just hyd. pump discharge while keeping engine rpm. System also takes SUMITOMO's unique EEP SA (Electrical Engine Pump Sensing Analyzer) to maximizes drum horsepower, and reduces horsepower loss with eliminating the possibility of engine stall.

Pump control system — By SUMITOMO's patented "SC" controller that provides two modes of engine-pump control.

MODE I:

The SC Controller is normally programmed to vary the engine speed and pump discharge simultaneously. Simply twisting the grip advances the engine to maximum speed and the hydraulic pumps to maximum flow at the same time. This mode is suitable to precision crane work.

MODE II:

By activating a switch, it is able to vary just the pump discharge by means of the grip throttle, while keeping engine speed fixed. Mode II is convenient for operations such as lifting magnet and bucket work, where the engine is normally run at full throttle.

HYDRAULIC SYSTEM:

System provided with three variable displacement axial piston pumps and one fixed displacement duplicate tandem gear pump for both independent and combined operations of all functions. Gear pump also used for system valves and cylinder controls.

Main/aux. crane hoist motors — Variable displacement axial piston motor with counterbalance valve.

Boom hoist motor — Axial piston type with counterbalance valve and spring-applied/

hydraulically released multiple wet-disc type automatic brake.

Third drum motor — Optional extra; axial piston type with counterbalance valve;

Swing motor — Two; axial piston type with spring-applied/hydraulically released multiple wet-disc type manually controlled brake.

Travel motors — Shoe-in design; axial piston motor with brake valve and spring-applied/hydraulically released multiple wet-disc type automatic brake.

Independent hyd. circuits — Available in between hydraulic circuits of P1 main pump and front main drum winch motor, and between P2 main pump and rear main drum winch motor.

Hydraulic oil reservoir — 410 liters capacity.

LOAD HOIST ASSEMBLY:

Front and rear main operating drums driven by independent hydraulic motor of bi-directional, variable displacement axial piston motor through 2-stage planetary reduction gear units powering the rope drum in either direction for hoisting and lowering load. Each of drum sized in same dimension.

Clutches — Internal expanding, self-adjusting, mono-band design with non-asbestos lining; spring-applied, power hydraulically released.

Brakes — 1,270mm dia. by 170mm wide brake drum; external contracting band type with non-asbestos lining; operated by power hydraulically assisted foot pedal with locking latch. Two brake modes are available; for crane operation, automatic brake, spring-applied, power hydraulically released is applied when control lever is in neutral position, and for bucket operation, free-fall is available in the above control lever position.

Drums — One piece, parallel grooved lagging with locking ratchet wheel cast integral; mounted on drum shaft through anti-friction bearings.

Drum locks — Electrically operated pawl.

Drum rollers — Optional extra; available for right cable winding onto drums.

BOOM HOIST ASSEMBLY:

Driven by bi-directional, axial piston hydraulic motor through 2-stage planetary reduction gear unit powering the rope drum in either direction for hoisting and lowering boom.

Brake — Spring-applied, power hydraulically released multiple wet-disc type automatic brake.

Drum — One piece, parallel grooved lagging with locking ratchet wheel cast integral; mounted on drum shaft through anti-friction bearings.

Drum lock — Power hydraulically operated pawl.

THIRD DRUM WINCH MECHANISM:

Optional extra; driven by bi-directional, axial piston hydraulic motor through planetary reduction gear units powering the rope drum in either direction for hoisting and lowering load. This is available for auxiliary lift.

Clutches — Internal expanding, self-adjusting, mono-band design with non-asbestos lining; spring-

applied, power hydraulically released.
Brakes — External contracting band type with non-asbestos lining; operated by power hydraulically assisted foot pedal with locking latch. Not only automatic brake but also free-fall modes are available.

Drums — One piece, parallel grooved lagging with locking ratchet wheel cast integral; mounted on drum shaft through anti-friction bearings.

Drum locks — Electrically operated pawl.

SWING:

Driven by two units of bi-directional, axial piston hydraulic motors through 2 sets of planetary reduction gear unit powering swing pinion. Swing pinion meshes with internal teeth of swing (ring) gear of turntable bearing inner race.

Brakes — Manually controlled; spring-applied, power hydraulically released multiple wet-disc type; provided on each of hydraulic motor.

Swing speed control — Max. swing speed can be tuned to arbitrary value by tuning dial that varies pump displacement.

Lock — Mechanically operated drop pin.

Speed — 2.1min.⁻¹ <2.1rpm>

GANTRY:

A-frame type; raised and lowered by power hydraulic cylinders.

OPERATOR'S CAB:

940mm wide; acoustically treated, all new stamped, automotive type, full-vision, cushion rubber mounted, well-ventilated, full compartment, roomy operator's cab with large curved front window; provided with an arrangement of "SC" control/swing lever, sunvisor, sunshade, rear-view mirrors, intermittent dual window shield wipers with washer on both front and roof windows, and roll-down window on sliding door.

Instrument panel — Contains engine monitoring lamps, display panel of SUMITOMO Model SML-10 Load Moment Limiter, and other necessary controllers and switches.

Operator's seat — Full adjustable reclining seat.

Anemometer — Optional extra; recommended for luffing towercrane attachment.

Stone guard — Optional extra; stainless steel-make. This is available for operator's cab protection from outside obstacles.

AM/FM radio — Provided as std. with clock.

Fire extinguisher — Optional extra; powder type with 1kg capacity.

MACHINERY CAB:

Equipped with hinged doors on both sides for machinery access and inspection; tape-type non-skid material applied to the roof.

CATWALKS:

Optional extra; hitched in place along both sides of machinery cab.

HYDRAULIC TAGLINE WINDER:

Optional extra; provided in front of upper revolving frame, and this is available for preventing a shake of suspended load like clamshell bucket by an 10mm dia. tug cable

with light force.

COUNTERWEIGHTS:

Weighs 45.0ton with cast, 5-block, removable, corner-rounded design. Five blocks consist of "A" (9,600kg), "B" (8,800kg), "C" (8,800kg), "D" (8,200kg), "E" (9,600kg).

AUXILIARY WEIGHT:

Weighs 1.5ton. Mounted on part of optional 3rd drum location; if 3rd drum optionally required, no this 1.5ton weight is required.

ELECTRICAL SYSTEM:

24-volt negative ground system; provided with two maintenance free 12-volt batteries.

LIGHTING SYSTEM:

Includes following lights.

- Two 70 W working lights;
- One 10 W interior cab light.

POWER UNIT:

Make & Model	Mitsubishi 6D24-T*
Type	Water-cooled, 4-cycle, direct injection, turbo-charged, diesel w/automatic cooling fan
No. of Cylinders	Six (6)
Bore & Stroke	130 mm x 150 mm
Displacement	11,945 cc
Rated Output	184 kW/2,000 min ⁻¹ < 250 ps/2,000 rpm >
Maximum Torque	981 N·m/1,400 min ⁻¹ < 100 kgf·m/1,400 rpm >
Fuel Tank	410 liters

*Note

6D24-TUG
EU Emission Regulations for Off-road Diesel Engines-
Stage 1
6D24-TE1
Japanese Emission Standards For Diesel Construction
Equipment Stage 1.

Undercarriage

CARBODY FRAME:

All-welded, precision machined, box type construction; A machined surface provided for mounting turntable bearing.

CARBODY JACK-UP DEVICE:

Contains four hydraulic jack cylinders attached on carbody jack cylinder beams for extending/retracting, and disassembling/assembling ease of crawler side frames.

Pontoon — All-welded construction; four pontoons each stored at an inside part of jack cylinder beams.

CRAWLER SIDE FRAMES:

All-welded, box type construction, precision machined; positioned on axle beam, and held in place by plate links.

Removal cylinders — For assisting in removing side frames.

Crawler side steps — Provided at both ends of the frames for easy access to superstructure.

DRIVE SPROCKETS:

Cast steel, heat treated; one per side frame. Track drive sprocket assembly bolt-coupled to 3-stage planetary reduction gear unit outer case as an integral part of shoe-in type traction motor. Sealed between parts of rotation and non-rotation of the motor with floating seal.

IDLER WHEELS:

Cast steel, heat treated; one per side frame. Mounted on two bronze bushings with floating seals for lifetime lubrication.

TRACK ROLLERS:

Eleven per side frame; each cast steel double flanged, heat treated. All rollers mounted on two bronze bushings with floating seals for lifetime lubrication.

CARRIER ROLLERS:

Two per side frame; each cast steel, double flanged and heat treated. All rollers mounted on two bronze bushings with floating seals for lifetime lubrication.

TRACKS:

Heat treated, self-cleaning, multiple hinged track shoes joined by full floating pins; 55 pcs. per side frame.

Shoe width — 965mm wide as standard.

Track adjustment — Manual adjustment device with oil jack and shim plate packs is standardized. As an optional extra, that idler wheels automatically adjusted while operation by means of hyd. cylinders actuated by power hydraulic supplied from operational hyd. pumps of superstructure is available instead.

TRAVEL AND STEERING:

A bi-directional, shoe-in type axial piston hydraulic motor bolt-couples drive sprocket thru 3-stage planetary reduction gear unit outer case

at each crawler side frame end for travel and steer. Straight-line travel (forward or reverse), pivot or differential turns, and counter-rotation for spin turns available.

Brake — Spring-applied, hydraulically released multiple wet-disc type automatic brake; located within hydraulic motor. Brakes automatically set when travel levers are in neutral or when engine is shut down.

Travel speed — 1.5/1.1km/hr.

Gradeability — 30% (17°) permissible based on basic machine without front-end attachment.

Safety Devices

SUMITOMO MODEL SML-10 LOAD MOMENT LIMITER:

This is a fully computerized total safe operation control system, and automatic over-load preventing system as standard equipment.

Construction (standard version) — Comprises (1) load detecting device with amplifier for general crane application (except luffing towercrane application), (2) angle detector for crane main boom/luffing towercrane boom (except tower jib), (3) computerized Micro Processing Unit (M.P.U.), and (4) display panel.

Functions — This system functions that if a lifting load reaches a 90% of the rated one specified in the crane capacity chart, an annunciating pre-warning (about to stop automatically) is given; if it is an 100%, a warning is given by red lamp, and annunciating warning (boom being overloaded), and all peril side motions are automatically stopped. The machine, however, can be operated in safety side motions.

Display panel indications — Followings are indication details on LCD 1 thru LCD 5:

- After operation modes were set by means of mode setting keys on panel, LCD 1 indicates:
 - liftcrane/luffing towercrane boom length;
 - kind of hook block (for boom of item 1);
 - no. of part-line (for hook block of item 2);
 - tower jib length;
 - kind of hook block (for tower jib of item 4);
 - no. of part-line (for hook block of item 5);
 - liftcrane boom/tower jib upper limit setting angle;
 - liftcrane boom/tower jib lower limit setting angle;
 - lifting curve number ("01" to "03");
 - "attached or non" of aux. short jib, and
 - lifting load ratio indication with 3 kinds of color lamping (green, yellow and red).
- LCD 2 indicates:
 - engine rpm, or

- lifting height.
- LCD 3 indicates:
 - present lifting load, or
 - rated load, or
 - remaining load.
 - LCD 4 indicates:
 - liftcrane/luffing towercrane boom angle.
 - LCD 5 indicates:
 - tower jib angle, or
 - fly jib offset angle;
 - present working radius, or
 - remaining working radius.

Display panel also provided with a fourteen-kind of indication lamp, and a function to indicate letter message on LCD 1 when machine becomes abnormal.

NON FREE-FALL OPERATION SWITCH:

This is for keeping non free-fall operation during operation when it is necessary. Provided with key for switch on-off control.

HOOK OVER-HOIST LIMITING DEVICE:

Interlocked with the SML-10 for automatically preventing a hook over-hoist of crane main boom with functions of automatic drum braking, and warnings by red lamp and annunciating alarm.

BOOM OVER-HOIST AND -LOWERING LIMITING DEVICE:

This is one of key safety devices; interlocked with the SML-10 also for automatically preventing boom over-hoist and -lowering with functions of automatic drum braking, and warnings by red lamp and annunciating alarm. Further boom protection from rapid boom over-hoist by hook over-hoist motion under mal-function of hook over-hoist limiting device is available as one of functions of the SML-10.

BOOM BACKSTOPS:

Dual; telescopic design with spring buffers.

DUAL BOOM OVER-HOIST LIMITING DEVICE:

Additional limit switch located on boom backstops; this is as a further safety device for redundant boom protection.

SWING LOCK:

Mechanically operated drop pin; available to firmly lock superstructure in four positions of facing front or rear or left or right to undercarriage.

DRUM LOCKS:

Electrically operated pawl locks is available on front and rear main drums while power hydraulically operated pawl lock is available on boom hoist drum with an automatic locking device as std.

THIRD DRUM LOCK:

Provided as std. when an optional 3rd drum winch is provided.

BOOM ANGLE INDICATOR:

Pendulum type; mounted on right-hand side of bottom section of crane main boom.

HOOK LATCH:

Provided on every kinds of hook to prevent out of place of cable from hook.

LEVEL GAUGE:

Bubble type; located on operator's cab floor of

Liftcrane 120 metric tons

superstructure and lower frame.

LEVER LOCKS:

Provided on all control levers (except swing lever) to lock levers in neutral.

SWING ALARM:

This is by buzzer, and flasher lamps located on both sides of machinery cab.

ANNUNCIATING ALARMS:

This is one of functions of the SML-10; provided with fifteen kinds of the alarm like "about to stop automatically".

SPEED SLOWDOWN DEVICE:

This is for speed slowdown of hoisting and lowering motions of crane main boom (and/or tower jib in case of luffing towercrane att.) which are available just before automatic stopping to prevent a shock.

SWING BRAKE LAMP:

Provided on operator's cab instrument panel; this is available to confirm whether or not swing brake is applied.

SIGNAL HORN:

Available as warning just before every kinds of motions from operator.

FOOL PROOF SHUT-OFF SYSTEM:

Located in the cab exit; this is available to automatically deactives and locks hydraulic system.

TRAVEL ALARM:

Buzzer warns when travel motion is initiated.

ENGINE MONITORING LAMPS:

Available for checking engine operating conditions like battery charge, engine oil pressure, radiator coolant level, oil filter clogging, air filter clogging, and battery electrolyte amount.

EMERGENCY MACHINE STOP BUTTONS:

Two; each located nearby front main and boom hoist drums. Available when it is necessary to stop all machine motion.

REAR VIEW MIRRORS:

Two each provided on front-left and -right corners of super-structure.

THREE COLOR PERCENTAGE INDICATOR:

Optional extra; this is with three colours of Green, Yellow and Red. Each colour indicates the load percentage to rated capacity; Green shows less than 90% as safety, Yellow shows 90 to 99% as marginal, and Red shows over 100% as over-loading. As further function, Red lamp comes on automatically when operator cuts off safety device switch absent-mindedly.

LIFTING HEIGHT METER:

Optional extra; available to indicate lifting height above ground or depth below ground on display "LCD 2" of SML-10 Load Moment Limiter display panel.

MICROPHONE & LOUD-SPEAKER:

Optional extra; this is for operator's convenience for loud speaking.

ANNUNCIATING SWING ALARM:

Optional extra; this is additional alarm for swing motion with a caution voice of "now

swing, keep clear please!".

ANNUNCIATING TRAVEL ALARM:

Optional extra; this is additional alarm for travel motion with a caution voice of "now travel, keep clear please!".

DRUM LIGHT & MIRROR:

Optional extra; these are available for checking rope winding onto front and/or rear drum(s).

AUX. CRANE HOOK OVER-HOIST LIMITING DEVICE:

Optional extra; this is available for auxiliary crane hoist with optional aux. short jib and/or fly jib. Performs the same function as that of "Hook over-hoist limiting device" mentioned before.

In addition to the above, following safety devices are standard for luffing towercrane attachment.

TOWER JIB ANGLE DETECTOR:

This is one of key safety device in a case of luffing towercrane attachment.

TOWERCRANE LOAD DETECTOR:

This is also important safety device when luffing towercrane attachment is required.

TOWER JIB OVER-HOIST AND -LOWERING LIMITING DEVICE:

Performs all the same function as that of "Boom over-hoist and -lowering limiting device" stated before.

TOWER JIB HOOK OVER-HOIST LIMITING DEVICE:

Performs the same function as that of "Hook over-hoist lifting device" described before.

TOWERCRANE ATT. SELF-ERECTION MODE:

This is an internal, integral mode as one of key function of the SML-10 for safe self-erection and -laying down of luffing towercrane attachment without fail.

TOWER JIB BACKSTOPS:

Dual; telescopic design with spring buffers.

DUAL TOWER JIB OVER-HOIST LIMITING DEVICE:

Additional limit switch located on tower jib backstops; this is as a further safety device for redundant tower jib protection.

CRANE BOOM:

Lattice construction, round tubular main chords, alloy, hi-ten steel, with bracing of round steel tubing.

Boom connections.....In-line pin connections at 1.85m deep and 1.85m wide.

Basic boom.....Two-piece, 15.25m basic length; 7.60m bottom section and 7.60m tapered crane top section.

Boom head machinery.....Six head sheaves and two guide sheaves mounted on anti-friction bearings.

Boom extensions.....Optional extra; available in 3.05m, 6.10m and 9.15m lengths with pendants.

Maximum boom length.....73.15m

FLY JIB:

Optional extra; lattice construction, round tubular main chords, alloy hi-ten steel, with bracing of round steel tubing having in-line pin connections at 0.762m deep and 0.914m wide, and jib head machinery with single sheave mounted on anti-friction bearings. Provided with jib strut, jib backstops, and jib/boom guyline pendants. Mounted on 7.60m tapered crane top section, and is available for light load lifting operation with less than 11ton with single part hoist line.

Basic fly jib.....Two-piece, 12.20m basic length; 6.10m bottom and top sections.

Fly jib extensions.....Available in 6.10m length with pendants.

Maximum fly jib length.....24.40m.

Boom plus fly jib length.....Max. 60.95m + 24.40m/64.00m + 18.30m.

AUXILIARY SHORT JIB:

Optional extra; all-welded construction having single sheave head machinery. Pinned to 7.60m tapered crane top section. Available for 11ton lift as maximum with single part hoist line.

HOOK BLOCKS:

120t, five sheaves with duplex type hook.....Optional extra.

50t, two sheaves.....Optional extra.

30t, one sheave.....Optional extra.

11t, ball hook.....Optional extra.

BAIL AND BRIDLE:

All-welded construction; provided with larger sheaves of a 21.4 D/d ratio on both bail and bridle for 12-part boom hoist rope reeving. Bail pinned to A-frame gantry, and bridle suspended between a 12-part boom hoist rope and pendant ropes connecting to tip of 7.60m tapered crane top section.

DRUM DATA:

Drum	Root dia.	Type	Line speed (Hoisting, Lowering)	Cable	Max. line pull
Front (main crane hoist) (towercrane hoist) (h/grab crown holding via hook) (c/bucket holding) (MHL/MEH bucket hoist)	520mm	Parallel grooved	120 ~ 2mpm	26mm	215kN (22.0ton)
Rear (aux. crane hoist) (tower jib hoist) (h/grab holding & closing) (c/bucket closing) (MHL/MEH bucket hoist)	520mm	Parallel grooved	120 ~ 2mpm *48 ~ 2mpm	26mm	215kN (22.0ton)
Boom hoist	526.4mm	Parallel grooved	51 ~ 2mpm	22.4mm	152kN (15.5ton)
Optional 3rd	448mm	Parallel grooved	60 ~ 2mpm	22.4mm	176kN (18.0ton)

Notes:

1. Line speed is based on drum first layer and rated engine rpm.

2. Hoisting line speed varies under load and operating conditions.

3. The figures with asterisk mark (*) indicate rope line speed in a case of luffing towercrane application.

Liftcrane Capacities

HOIST REEVING:

ton

hook	No. of partline											
		11	10	9	8	7	6	5	4	3	2	1
120t	120.0	110.0	99.0	88.0	77.0	66.0	55.0	44.0	33.0	—	11.0	
50t	—	—	—	—	—	—	50.0	44.0	—	—	11.0	
30/20t	—	—	—	—	—	—	—	—	30.0	22.0	11.0	
11t	—	—	—	—	—	—	—	—	—	—	11.0	

CABLES:

- Front drum P-S (19)+39xP-7, non-spin type, 26mm dia./300m long, breaking load 651kN (66.4t).
- Rear drum P-S (19)+39xP-7, non-spin type, 26mm dia./200m long, breaking load 651kN (66.4t).
- Boom hoist drum XP rope with construction of IWRC 6xWS (31), 22.4mm dia./198m long, breaking load 367kN (37.4t).
- Optional 3rd drum Optional extra, XP rope with construction of IWRC 6xWS (26), 22.4mm dia./220m long, breaking load 367kN (37.4t).

WORKING WEIGHT & GROUND PRESSURE:

Shoe width	Weight	Pressure
965mm	116.0t	83.0kPa <0.85kg/cm²>

Note: Working weights shown above are respectively with 15.25m basic boom, 45.0ton std. c.t.w.t, 1.5ton auxiliary weight, and optional 120t hook block.

Boom length (m) Working radius (m)	15.25	18.30	21.35	24.40	27.45	30.50	33.50	36.55	39.60	42.65	45.70	48.75	51.80	54.85	57.90	60.95	64.00	67.05	70.10	73.15
4.5	120.0																			
5.0	117.0	105.5/5.1																		
5.5	107.1	103.6	93.8/5.6																	
6.0	98.7	98.1	92.2	83.5/6.1	73.9/6.7															
7.0	85.3	84.7	84.5	80.4	73.0	65.9/7.2	59.5/7.7													
8.0	71.9	71.7	71.7	71.6	70.3	64.1	58.9	53.4/8.3	48.4/8.8											
9.0	60.0	59.8	59.8	59.7	59.7	59.6	57.0	52.3	48.1	43.6/9.3	39.6/9.8									
10.0	51.4	51.2	51.1	51.0	51.0	50.9	50.8	50.1	46.8	42.8	39.4	33.0/10.4	32.0/10.9	29.1/11.4						
12.0	39.8	39.5	39.4	39.3	39.3	39.2	39.0	39.0	38.8	38.8	37.6	33.0	31.2	28.7	26.3	22.0/12.5	21.4/13.1	19.3/13.6		
14.0	32.3	31.9	31.8	31.7	31.7	31.6	31.4	31.3	31.2	31.2	31.0	31.0	29.9	27.5	25.2	22.0	21.0	19.1	17.4/14.1	15.7/14.6
16.0	30.0/14.8	26.7	26.6	26.4	26.4	26.2	26.1	26.0	25.8	25.8	25.7	25.6	25.5	25.3	24.1	22.0	20.1	18.4	16.7	15.2
18.0		24.0/17.4	22.7	22.5	22.4	22.3	22.1	22.1	21.9	21.9	21.7	21.6	21.5	21.4	21.2	21.1	19.3	17.6	16.1	14.6
20.0			19.8	19.6	19.5	19.4	19.2	19.1	19.0	18.9	18.7	18.6	18.5	18.3	18.1	18.0	16.9	15.2	13.4	
22.0				17.3	17.2	17.0	16.9	16.8	16.5	16.4	16.4	16.2	16.0	15.9	15.7	15.7	15.5	15.4	13.9	12.2
24.0				16.7/22.7	15.3	15.1	14.9	14.8	14.6	14.5	14.4	14.3	14.1	13.9	13.7	13.7	13.6	13.4	12.8	11.1
26.0					14.3/25.3	13.5	13.4	13.3	13.0	12.9	12.8	12.7	12.6	12.3	12.1	12.1	11.9	11.7	11.6	10.2
28.0						12.3	12.0	11.9	11.7	11.6	11.4	11.3	11.2	11.0	10.7	10.7	10.6	10.4	10.2	9.4
30.0							10.9	10.8	10.5	10.4	10.2	10.1	10.0	9.8	9.6	9.6	9.5	9.3	9.1	8.6
32.0							10.6/30.6	9.8	9.5	9.4	9.2	9.1	9.0	8.8	8.6	8.6	8.4	8.2	8.1	7.9
34.0								9.3/33.2	8.7	8.6	8.4	8.3	8.1	7.9	7.7	7.7	7.5	7.3	7.2	7.0
36.0									8.0/35.9	7.8	7.7	7.5	7.3	7.2	6.9	6.9	6.7	6.5	6.4	6.2
38.0										7.2	7.0	6.8	6.7	6.5	6.3	6.2	6.0	5.8	5.7	5.5
40.0										7.0/38.5	6.4	6.3	6.1	5.9	5.7	5.6	5.4	5.2	5.0	4.8
42.0											6.1/41.1	5.7	5.6	5.4	5.1	5.0	4.8	4.5	4.3	4.1
44.0												5.3/43.8	5.1	4.9	4.6	4.5	4.3	4.0	3.8	3.6
46.0													4.6	4.4	4.1	4.0	3.8	3.5	3.3	3.1
48.0													4.6/46.4	4.0	3.7	3.5	3.3	3.0	2.8	2.6
50.0														3.7/49.1	3.3	3.1	2.9	2.6	2.4	2.2
52.0															2.9/51.7	2.8	2.5	2.3	2.1	
54.0																2.4	2.2			
56.0																2.2/54.1				

(EC400101)

Liftcrane Working Ranges

Notes — Liftcrane capacities

- Capacities included in this chart are the maximum allowable, and are based on machine standing level on firm supporting surface under ideal job conditions.
- Capacities are in metric tons, and are not more than 78% of minimum tipping loads except the figures surrounded by bold lines which are based on other factor of machine structural strength limitation.
- Capacities are based on freely suspended loads and make no allowance for such factors as the effect of wind, sudden stopping of loads, supporting surface conditions, and operating speeds. Operator must reduce load ratings to take such conditions into account. Deduction from rated capacities must be made for weight of hook block, weighted ball/hook, sling, spreader bar, or other suspended gear.
SUMITOMO's hook block weight is as follows:
120t.....1.4ton 50t.....0.9ton 30t.....0.73ton
11t.....0.4ton
- All capacities are rated for 360° swing.
- Least stable rated condition is over the side.
- A 45.0ton counterweight and 1.5ton auxiliary weight (or opt. 3rd drum winch) are required for all capacities on this chart.
- Attachment must be erected and lowered over the ends of the crawler mounting.
- Main boom length must not exceed 73.15m.
Maximum fly jib length permitted—24.40m.
Maximum boom and fly jib combination length permitted—60.95m+24.40m/64.00m+18.30m.
Maximum boom length when mounting auxiliary short jib is 70.10m.
- Capacities when handling load off main boom head sheaves in case of mounting fly jib or auxiliary short jib on top of boom are detailed; if required, please consult us or nearest distributor.
- Boom combination shall be in accordance with manufacturer's standard described here in "Boom Combination Diagram".
- Capacities apply only to machine as originally manufactured and normally equipped by Sumitomo Heavy Industries Construction Crane Co., Ltd.

SC1200 AUXILIARY SHORT JIB CAPACITIES:

Max. 11.0ton

Note: Jib capacities is almost equal to the figures made by the deduction of an 400kg from the liftcrane capacities for boom length up to 70.10m unless restricted by the maximum jib capacity shown above. As to the details, please consult us or nearest distributor.

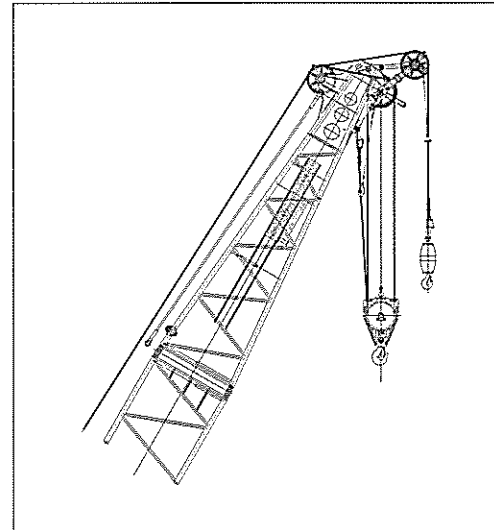

Auxiliary short jib (Option)

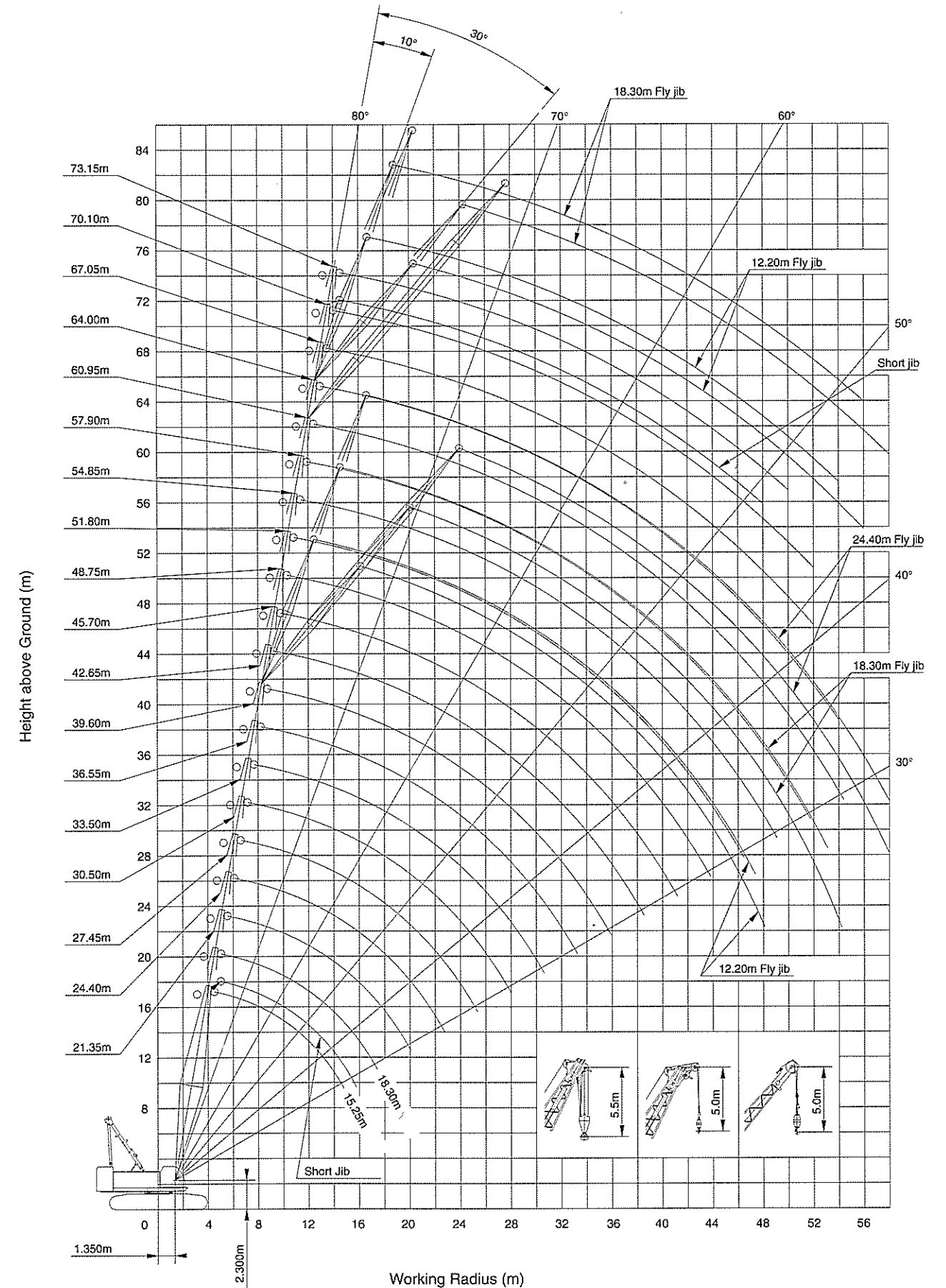

Boom Combination Diagram

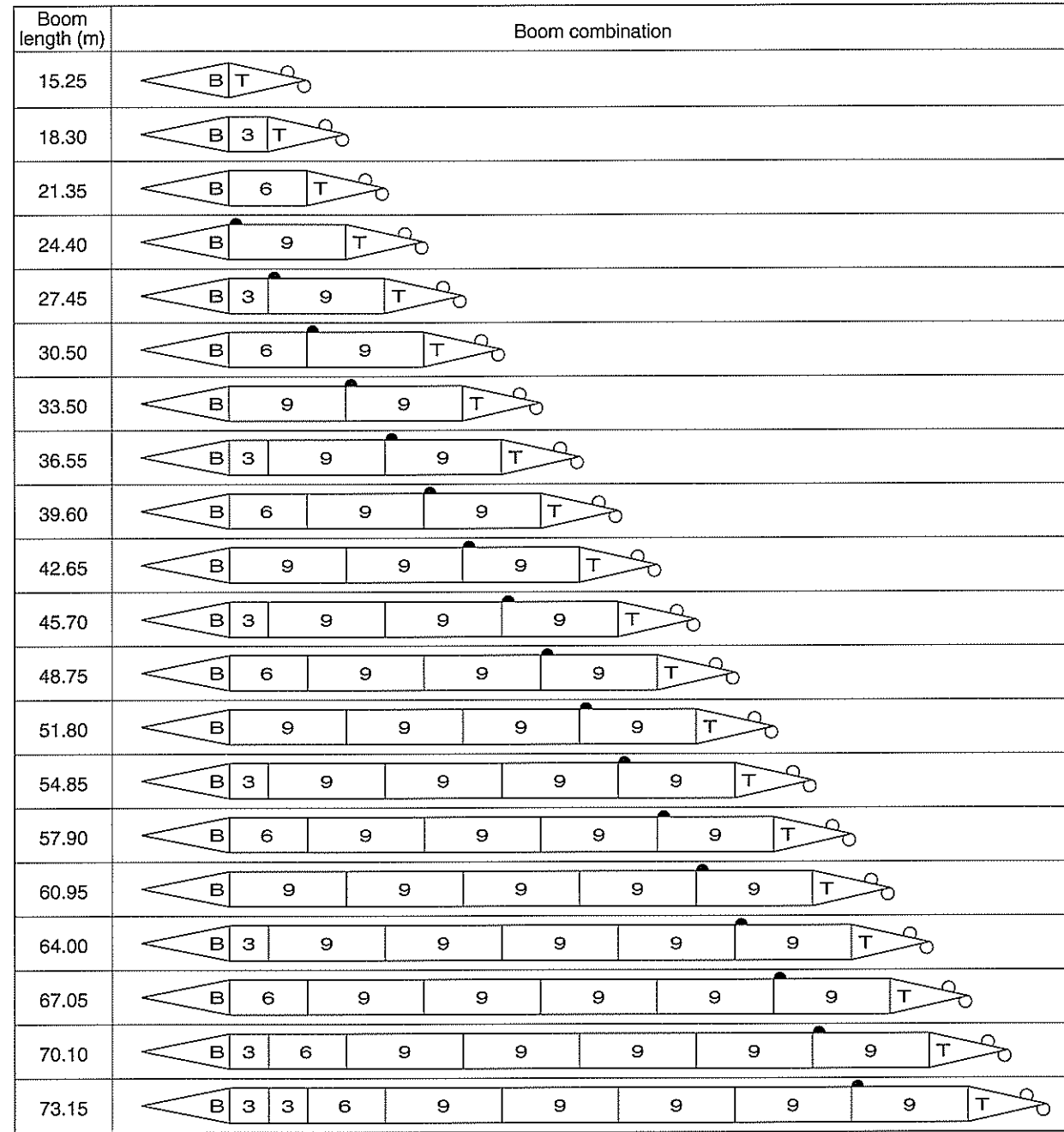

Note:
The meanings of figures and symbols shown above are as follows:

- : 9.15m boom extension
- : 6.10m boom extension
- : 3.05m boom extension
- : 7.60m bottom section
- : 7.60m tapered top section
- : Boom guyline cables installing position; the boom guyline cables are required for fly jib attachment which can be mounted on boom from 39.60m up to 64.00m.

Fly Jib Capacities

Boom length (m)	39.60						42.65						45.70						
	12.20		18.30		24.40		12.20		18.30		24.40		12.20		18.30		24.40		
	Jib offset angle (°)	Working radius (m)	Jib offset angle (°)	Working radius (m)	Jib offset angle (°)	Working radius (m)	Jib offset angle (°)	Working radius (m)	Jib offset angle (°)	Working radius (m)	Jib offset angle (°)	Working radius (m)	Jib offset angle (°)	Working radius (m)	Jib offset angle (°)	Working radius (m)	Jib offset angle (°)	Working radius (m)	
12.0	11.0/12.9						11.0/13.5												
14.0	11.0	8.0/15.9	10.0/15.5				11.0						11.0						
16.0	11.0	8.0	10.0			6.0/17.7		11.0	8.0/16.4	10.0			11.0	8.0	10.0				
18.0	11.0	8.0	10.0	6.0/19.7	6.0			11.0	8.0	10.0			6.0/18.2			11.0	8.0	10.0	
20.0	11.0	8.0	10.0	6.0	6.0			11.0	8.0	10.0	6.0/20.3	6.0			11.0	8.0	10.0	6.0/20.8	6.0
22.0	11.0	8.0	10.0	6.0	6.0	4.5/23.3		11.0	8.0	10.0	6.0	6.0	4.5/23.8		11.0	8.0	10.0	6.0	6.0
24.0	11.0	8.0	10.0	6.0	6.0	4.5	11.0	8.0	10.0	6.0	6.0	4.5	11.0	8.0	10.0	6.0	6.0	4.5	4.5/24.3
26.0	11.0	8.0	10.0	6.0	6.0	4.5	11.0	8.0	10.0	6.0	6.0	4.5	11.0	8.0	10.0	6.0	6.0	4.5	
28.0	11.0	8.0	10.0	6.0	6.0	4.5	11.0	8.0	9.9	6.0	6.0	4.5	11.0	8.0	9.7	6.0	6.0	4.5	
30.0	10.9	8.0	10.0	6.0	6.0	4.5	10.7	8.0	9.7	6.0	6.0	4.5	10.6	8.0	9.3	6.0	6.0	4.5	
32.0	9.9	8.0	9.7	6.0	6.0	4.5	9.7	8.0	9.4	6.0	6.0	4.5	9.5	8.0	8.9	6.0	6.0	4.5	
34.0	9.0	7.8	9.2	6.0	6.0	4.5	8.8	8.0	8.9	6.0	6.0	4.5	8.7	8.0	8.4	6.0	6.0	4.5	
36.0	8.2	7.6	8.4	6.0	6.0	4.5	8.0	7.8	8.3	6.0	6.0	4.5	7.9	8.0	7.9	6.0	6.0	4.5	
38.0	7.5	7.4	7.8	6.0	6.0	4.5	7.3	7.5	7.6	6.0	6.0	4.5	7.2	7.4	7.4	6.0	6.0	4.5	
40.0	6.9	7.0	7.1	5.9	5.8	4.5	6.7	6.9	7.0	5.7	5.9	4.5	6.6	6.8	6.8	5.5	6.0	4.5	
42.0	6.3	6.5	6.6	5.4	5.7	4.5	6.2	6.3	6.4	5.4	5.8	4.5	6.0	6.2	6.3	5.4	5.9	4.5	
44.0	5.8	5.9	6.1	5.2	5.5	4.5	5.7	5.8	5.9	5.3	5.6	4.5	5.5	5.7	5.8	5.4	5.8	4.5	
46.0	5.4	5.5	5.6	5.1	5.5	4.5	5.2	5.3	5.4	5.2	5.5	4.4	5.1	5.2	5.3	5.3	5.5	4.2	
48.0	5.0/47.7	5.0	5.2	5.0	5.3	4.2	4.8	4.9	5.0	5.1	5.2	4.0	4.7	4.8	4.9	5.1	5.0	4.1	
50.0		4.9/48.3	4.8	4.9	5.0	4.0	4.4	4.5	4.6	4.8	4.8	4.0	4.2	4.3	4.5	4.7	4.7	4.0	
52.0			4.4	4.5	4.6	3.9	4.4	4.5	4.6	4.3	4.4	3.9	3.8	3.9	4.1	4.3	4.3	4.0	
54.0			4.2/53.6	4.2	4.3	3.8				3.9	4.0	4.1	3.9	3.6/52.9	3.5/53.6	3.7	3.9	3.9	
56.0				4.1/54.4	4.0	3.7				3.6	3.7	3.8	3.8			3.4	3.5	3.6	
58.0					3.7	3.6				3.5/56.2	3.5/57.1	3.4	3.6			3.0	3.1	3.2	

Boom length (m)	48.75						51.80						54.85						
	12.20		18.30		24.40		12.20		18.30		24.40		12.20		18.30		24.40		
	Jib offset angle (°)	Working radius (m)	Jib offset angle (°)	Working radius (m)	Jib offset angle (°)	Working radius (m)	Jib offset angle (°)	Working radius (m)	Jib offset angle (°)	Working radius (m)	Jib offset angle (°)	Working radius (m)	Jib offset angle (°)	Working radius (m)	Jib offset angle (°)	Working radius (m)	Jib offset angle (°)	Working radius (m)	
12.0																			
14.0	11.0/14.5						11.0/15.0								11.0/15.6				
16.0	11.0	8.0/17.5	10.0/17.0				11.0	8.0	10.0/17.6				11.0	8.0	10.0				
18.0	11.0	8.0	10.0			6.0/19.2		11.0	8.0	10.0			6.0/19.8			11.0	8.0	10.0	
20.0	11.0	8.0	10.0	6.0/21.3	6.0			11.0	8.0	10.0	6.0/21.8	6.0			11.0	8.0	10.0	6.0/22.4	6.0
22.0	11.0	8.0	10.0	6.0	6.0			11.0	8.0	10.0	6.0	6.0			11.0	8.0	10.0	6.0/22.4	6.0
24.0	11.0	8.0	10.0	6.0	6.0	4.5/24.9		11.0	8.0	10.0	6.0	6.0	4.5/25.4		11.0	8.0	10.0	6.0	4.5/25.9
26.0	11.0	8.0	10.0	6.0	6.0	4.5	11.0	8.0	10.0	6.0	6.0	4.5	11.0	8.0	10.0	6.0	6.0	4.5	
28.0	11.0	8.0	9.6	6.0	6.0	4.5	11.0	8.0	9.4	6.0	6.0	4.5	11.0	8.0	9.2	6.0	6.0	4.5	
30.0	10.4	8.0	9.2	6.0	6.0	4.5	10.2	8.0	8.9	6.0	6.0	4.5	10.1	8.0	8.7	6.0	6.0	4.5	
32.0	9.3	8.0	8.7	6.0	6.0	4.5	9.2	8.0	8.4	6.0	6.0	4.5	9.0	8.0	8.3	6.0	6.0	4.5	
34.0	8.4	8.0	8.2	6.0	6.0	4.5	8.3	8.0	7.9	6.0	6.0	4.5	8.2	8.0	7.8	6.0	6.0	4.5	
36.0	7.7	7.9	7.7	6.0	6.0	4.5	7.5	7.8	7.5	6.0	6.0	4.5	7.4	7.7	7.3	6.0	6.0	4.5	
38.0	7.0	7.2	7.2	5.9	6.0	4.5	6.8	7.1	7.0	5.9	6.0	4.5	6.7	6.9	6.8	6.0	6.0	4.5	
40.0	6.4	6.6	6.6	5.7	6.0	4.5	6.2	6.4	6.5	5.8	6.0	4.5	6.1	6.3	6.3	5.8	6.0	4.5	
42.0	5.8	6.0	6.1	5.5	6.0	4.5	5.6	5.9	5.9	5.6	6.0	4.5	5.5	5.7	5.8	5.7	6.0	4.5	
44.0	5.3	5.5	5.5	5.4	5.7	4.5	5.1	5.3	5.4	5.5	5.6	4.5	5.0	5.2	5.2	5.6	5.4	4.5	
46.0	4.8	5.0	5.1	5.2	5.3	4.3	4.7	4.8	4.9	5.2	5.1	4.3	4.5	4.7	4.8	5.1	5.0	4.4	
48.0	4.4	4.6	4.7	4.9	4.8	4.1	4.2	4.4	4.5	4.8	4.7	4.2	4.0	4.2	4.3	4.6	4.5	4.3	
50.0	4.0	4.1	4.3	4.5	4.4	4.0	3.8	3.9	4.1	4.3	4.3	4.1	3.5	3.7	3.9	4.2	4.1	4.2	
52.0	3.6	3.7	3.9	4.1	4.1	3.9	3.4	3.5	3.7	3.9	3.9	4.0	3.1	3.3	3.4	3.7	3.7	4.1	
54.0	3.2	3.3	3.5	3.7	3.7	3.9	3.0	3.1	3.3	3.5	3.5	3.8	2.8	2.9	3.1	3.3	3.3	3.7	
56.0	2.9/55.6	2.9	3.1	3.3	3.4	3.6	2.7	2.8	2.9	3.1	3.2	3.5	2.4	2.5	2.7	2.9	2.9	3.3	
58.0		2.9/56.3	2.8	3.0	3.0	3.3	2.3	2.4	2.6	2.8	2.8	3.1	2.1	2.2	2.4	2.6	2.6	2.9	

Boom length (m)	57.90						60.95						64.00					
	12.20		18.30		24.40		12.20		18.30		24.40		12.20		18.30			
	Jib offset angle (°)	Working radius (m)	Jib offset angle (°)	Working radius (m)	Jib offset angle (°)	Working radius (m)	Jib offset angle (°)	Working radius (m)	Jib offset angle (°)	Working radius (m)	Jib offset angle (°)	Working radius (m)	Jib offset angle (°)	Working radius (m)	Jib offset angle (°)	Working radius (m)		
12.0																		
14.0																		
16.0	11.0/16.1						11.0/16.6						11.0/17.2					
18.0	11.0	8.0/19.1	10.0/18.6				11.0	8.0/19.6	10.0/19.2				11.0	8.0	10.0/19.7			
20.0	11.0	8.0	10.0			6.0/20.8		11.0	8.0	10.0			6.0/21.4			11.0	8.0/20.1	10.0
22.0	11.0	8.0	10.0	6.0/22.9	6.0			11.0	8.0	10.0	6.0/23.4	6.0			11.0	8.0	10.0	
24.0	11.0	8.0	10.0	6.0	6.0			11.0	8.0	10.0	6.0	6.0			11.0	8.0	10.0	6.0
26.0	11.0	8.0	10.0	6.0	6.0	4.5/26.5		11.0	8.0	10.0	6.0	6.0	4.5/27.0		10.2	8.0	9.9	6.0
28.0	11.0	8.0	9.1	6.0	6.0	4.5	10.5	8.0	8.9	6.0	6.0	4.5	9.5	8.0	8.8	6.0	6.0	
30.0	9.8	8.0	8.5	6.0	6.0	4.5	9.7	8.0	8.3	6.0	6.0	4.5	8.8	8.0	8.1	6.0	6.0	
32.0	8.8	8.0	8.0	6.0	6.0	4.5	8.7	8.0	7.8	6.0	6.0	4.5	8.1	8.0	7.6	6.0	6.0	
34.0	7.9	8.0	7.6	6.0	6.0	4.5	7.8	8.0	7.3	6.0	6.0	4.5	7.5	8.0	7.1	6.0	6.0	
36.0	7.1	7.5	7.1	6.0	6.0	4.5	7.0	7.3	6.9	6.0	6.0	4.5	6.8	7.2	6.6	6.0	6.0	
38.0	6.5	6.7	6.6	6.0	6.0	4.5	6.3	6.6	6.4	6.0	6.0	4.5	6.2	6.5	6.2	6.0	6.0	
40.0	5.8	6.1	6.1	5.9	6.0	4.5	5.7	6.0	6.0	6.0	6.0	4.5	5.5	5.8	5.8	6.0	6.0	
42.0	5.3	5.5	5.6	5.8	5.8	4.5	5.1	5.4	5.4	5.8	5.6	4.5	4.9	5.2	5.3	5.7	6.0	
44.0	4.7	5.0	5.0	5.4	5.2	4.5	4.5	4.8	4.9	5.2	5.1	4.5	4.3	4.6	4.7			

Clamshell 2m³ over

Notes — Fly jib capacities

- Capacities included in these charts are the maximum allowable, and are based on machine standing level on firm supporting surface under ideal job conditions.
- Capacities are in metric tons, and are based on 78% of minimum tipping loads except the figures surrounded by bold lines which are based on other factor of machine structural strength limitation.
- Capacities are based on freely suspended loads and make no allowance for such factors as the effect of wind, sudden stopping of loads, supporting surface conditions, and operating speeds. Operator must reduce load ratings to take such conditions into account. Deduction from rated jib capacities must be made for weight of hook block, weighted ball/hook, sling, spreader bar, or other suspended gear. SUMITOMO's hook block weight is as follows:
11t.....0.4ton
- All capacities are rated for 360° swing.
- Least stable rated position is over the side.
- A 45.0ton counterweight and 1.5ton auxiliary weight (or opt. 3rd drum winch) are required for all capacities on these charts.
- Attachment must be erected and lowered over the ends of the crawler mounting.
- Maximum fly jib length permitted is 24.40m, and maximum boom and fly jib combination length permitted is 60.95m boom plus 24.40m fly jib, or 64.00m boom plus 18.30m fly jib.
- Capacities apply only to the machine as originally manufactured and normally equipped by Sumitomo Heavy Industries Construction Crane Co., Ltd.

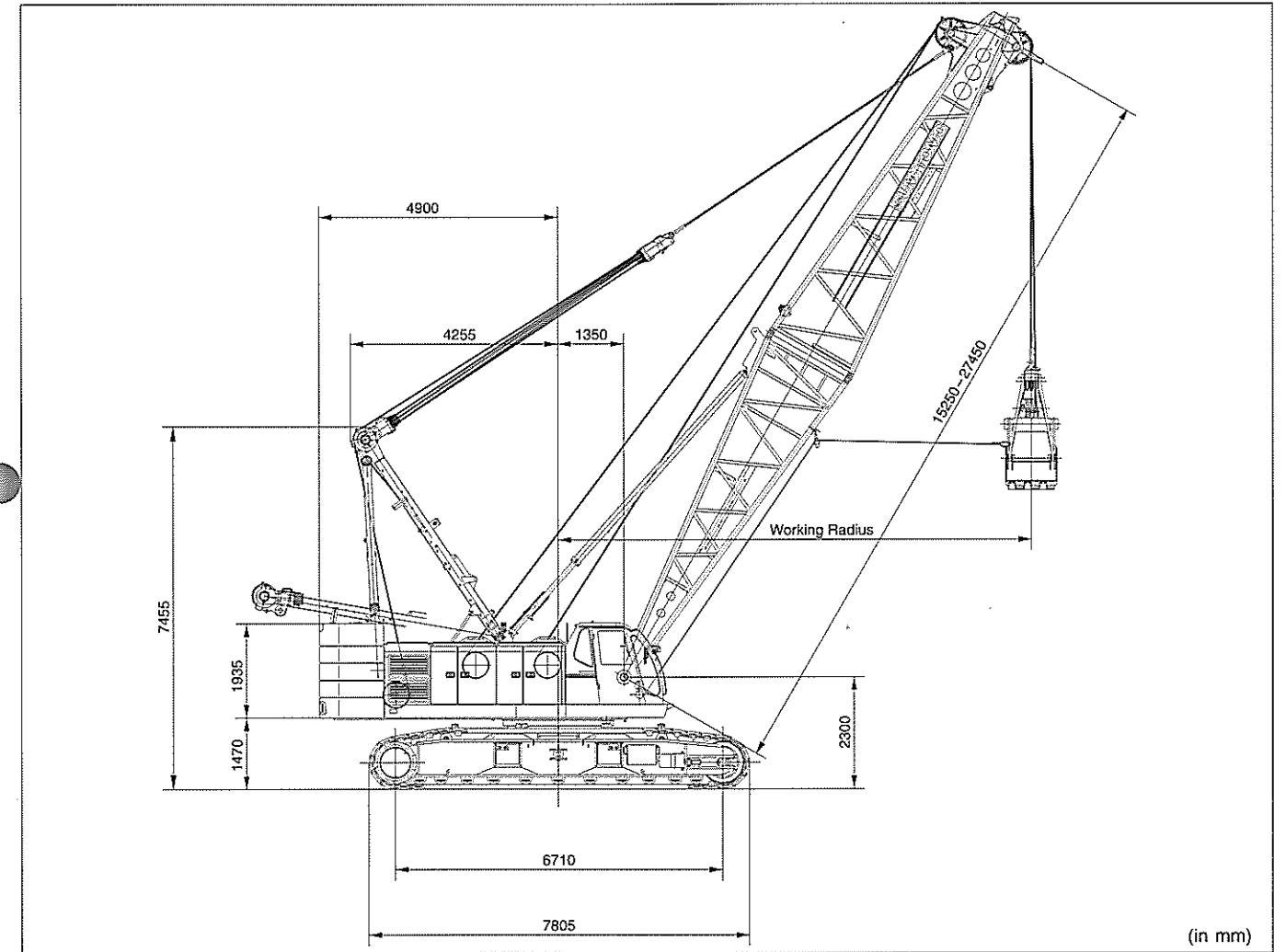

CLAMSHELL CAPACITIES:

(in metric tons)

Boom length (m) Working radius (m)	15.25	18.30	21.35	24.40	27.45
8.0	10.0				
9.0	10.0	10.0			
10.0	10.0	10.0	10.0		
12.0	10.0	10.0	10.0	10.0	
14.0	10.0	10.0	10.0	10.0	10.0
16.0		10.0	10.0	10.0	10.0
18.0			10.0	10.0	10.0
20.0				10.0	10.0
22.0					10.0

Notes:

- Max. clamshell rating is 10.0ton.
- Following weight of bucket plus load should not exceed clamshell capacities shown above.

Bucket capacity	2.0m ³	2.5m ³	3.0m ³
Bucket weight	4.5t	5.5t	6.5t

- Boom length shall not exceed 27.45m.
- Apparent specific gravity of lifting material:
Earth1.7~1.8t/m³
Gravel1.8~2.0t/m³

BUCKET DIMENSIONS:

(in m)

	2.0m ³	2.5m ³	3.0m ³
A Bucket overall height (opened)	4.52	4.37	5.37
B Bucket overall height (closed)	3.69	3.46	4.36
C Bucket opening width	3.24	3.65	3.65

Notes:

- Buckets of 2.0/2.5m³ are for general excavating purpose.
- A 3.0m³ bucket is for light-duty service.

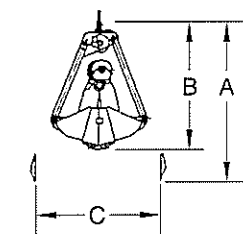

Standard and Optional Equipment

	Standard equipment	Optional equipment
Superstructure	<ul style="list-style-type: none"> • Mitsubishi 6D24-T diesel engine with an 184kW <250ps> rated output; • Hydraulic system with three variable displacement axial piston pumps and one fixed displacement duplicate tandem gear pump; • Control system with one each of duplicate and triplicate tandem valves and pilot-operated arm chair single axis control levers; • Motorcycle type "SC" controller (easy-precise-minute engine rpm and hyd. pump oil flow control device); • Front and rear main operating drum winches of 22ton line pull with 520mm dia. drum lagging driven by independent variable hyd. motor with independent hyd. circuit; provided with an 1,270mm dia. by 170mm wide external contracting band brake capable of two functions of automatic and free-fall mode, with hyd. booster; • Boom hoist mechanism driven by hyd. motor with automatic brake; • Swing mechanism with turntable bearing; driven by two hyd. motors w/manually controlled multiple wet-disc brake; • Power hydraulically retractable A-frame gantry; • All new stamped, automotive type, full-vision operator's cab with large curved front window; provided with an arrangement of control system and instrument panel; • 45.0ton counterweight; • 1.5ton auxiliary weight; if optional 3rd drum is required, this 1.5ton aux. weight is deleted; • Machinery cab with hinged doors; • 24-volt electrical system with two 12-volt batteries; • Lighting system: <ul style="list-style-type: none"> • Two 70W working lights; • One 10W interior cab light; • Accessories: <ul style="list-style-type: none"> • AM/FM radio w/clock; • Engine hourmeter; • Engine tachometer; • Fuel gauge; • Thermometer; • Hyd. oil temp. gauge; • Pilot line pressure gauge; • Foot throttle; • Intermittent dual window shield wipers with washers; • Cigar lighter; • Ash tray; • Book holder; • Sunvisor; • Sunshade; • Cup Holder; • Non-skid surfaces; • Cab front step; • Cab floor mat; • Superstructure under-cover. • Std. spare parts and tools. 	<ul style="list-style-type: none"> • Third drum winch; • Third drum cable, 22.4mm dia./220m long; • Tagline winder; • Anemometer; recommended for luffing tower crane operation; • Drum rollers; available on front/rear main; • Stone guard; this is for operator's cab; • Fire extinguisher; • Catwalks, along both sides of machinery cab; • Built-in type full air-conditioning; • Re-fuel pump; • Heater.

	Standard equipment	Optional equipment
Undercarriage	<ul style="list-style-type: none"> • 5,400mm gauge by 7,805mm long crawler lower with removable crawler side frames; • Crawler drive units with shoe-in type traction motor with wet-disc type automatic brakes; • 965mm wide track shoes; • Manual track tension adjusting devices; • Carbody jack-up device w/4-vertical hyd. jack-up cylinder and remote control unit; • Lifetime lubricated track components; • Crawler side steps. 	<ul style="list-style-type: none"> • Automatic track tension adjusting device, i/o manual one as std.
Liftcrane Att.	<ul style="list-style-type: none"> • 15.25m basic crane boom; 7.60m bottom section and 7.60m tapered crane top section w/six head and two guide sheaves; • Bail and bridle assemblies; • Main crane hoist cable; 26mm dia./300m long; • Boom hoist cable; 22.4mm dia./198m long. 	<ul style="list-style-type: none"> • 3.05m boom extension; • 6.10m boom extension; • 9.15m boom extension; • 12.20m basic fly jib; 6.10m bottom and top sections with strut and guyline pendants; • 6.10m fly jib extension; • Auxiliary short jib; • 120t duplex type hook block; • 50t hook block; • 30t hook block; • 11t ball hook; • Aux. crane hoist cable, 26mm dia./200m long.

