

■ Main Specifications

Description		SCX800HD	SCX900HD-1	SCX1200HD	SCX2000HD
Nominal lifting cap.	⟨t⟩	80	90	120	200
Basic boom length	⟨m⟩	12.85	12.20	15.25	15.25
Max. boom length	⟨m⟩	55.50	60.95	73.15	73.15
Rope line speed	Front main drum ⟨m/min⟩	120	100	95	95
	Rear main drum ⟨m/min⟩	120	100	95	95
	Boom hoist drum ⟨m/min⟩	70	51	51	48
	3rd drum(opt.) ⟨m/min⟩	120	59	59	—
Swing speed	⟨min ⁻¹ ⟩	3.5	2.9	2.1	1.7
Travel speed	⟨km/h⟩	1.6	1.8	1.5/1.1	1.2
Engine	Make & model	Mitsubishi 6D24-TL(*1)	Mitsubishi 6D24-TL(*1)	Isuzu BB-6WG1X	Isuzu BB-6WG1X
	Type	Water-cooled, 4-cycle direct injection, turbo-charged diesel w/inter-cooler	Water-cooled, 4-cycle direct injection, turbo-charged diesel w/inter-cooler	Water-cooled, 4-cycle direct injection, turbo-charged diesel w/inter-cooler	Water-cooled, 4-cycle direct injection, turbo-charged diesel w/inter-cooler
	Rated output ⟨kW⟩	184	235	353	353
	Max. torque ⟨N·m⟩	1155	1245	1893	1893
Max. dragline rating	⟨t⟩	10	12.5	(*2)	(*2)
Max. clamshell rating	⟨t⟩	10	12.5	15.0	15.0
Dragline bucket capacity	⟨m ³ ⟩	2.0 over	2.5 over	(*2)	(*2)
Clamshell bucket capacity	⟨m ³ ⟩	2.0 over	2.5 over	3.0	3.0
Max. hammergrab weight	⟨t⟩	7.0	7.0	(*3)	(*3)
Gradeability	⟨%⟩	40	30	30	30
Ground pressure	⟨kPa⟩	Approx. 88	Approx. 91	Approx. 86	Approx. 111
Operating weight	⟨t⟩	Approx. 78	Approx. 87	Approx. 120	Approx. 205

- Notes:
1. Units in this specification are under Int'l System of Units.
 2. Rope line speeds vary under load and operating conditions.
 3. Operating weights are each under liftcrane application with basic boom and opt. hook block of nominal capacity, and ground pressures are defined under the said operating weight respectively.
 4. Max. boom lengths are the figures when liftcrane application. In case of bucket applications, boom length as applicable is from around 15m to 30m; as to the details, please refer to separate Specifications of respective models.
 5. Dragline and clamshell bucket capacities each indicate the figure under general excavating/digging application.
 6. As to dragline application for SCX1200HD and SCX2000HD, please consult us or nearest Distributor (*2).
 7. In respect to applicable hammergrab weight for SCX1200HD and SCX2000HD, please consult us or nearest Distributor also (*3).
 8. Two kinds of engine models are available; one is 6D24-TLU2F for EU Emission Regulations for Off-Road Diesel Engine - Stage 2, and the other is 6D24-TLE2A for Japanese Emission Standards for Diesel Construction Equipment - Stage 2 (*1).

· We are constantly improving our products and therefore reserve the right to change designs and specifications without notice.
 · Illustrations may include optional equipment and accessories, and may not include all standard equipment.
 · Painting color other than blue-and-white shown in this catalog shall be optionally available.

Address inquires to:

**Hitachi Sumitomo Heavy Industries
Construction Crane Co., Ltd.**

12-14, Ueno 7-chome, Taito-ku, Tokyo 110-0005, Japan
 Phone: 81-3-3845-1387 Facsimile: 81-3-3845-1394

Hydraulic Cable Excavators & Crawler Cranes

**SCX800HD
SCX900HD-1
SCX1200HD
SCX2000HD**



HEAVY DUTY

Four Heavy Duty Machines.

To match with heavy duty digging and excavating works certainly under dragline, clamshell, hammergrab and diaphragm wall bucket applications, a durable hydraulic power pack and heavy duty winches with bigger engine are well designed. Now, they unveil to work there with you. No doubt. They surely provide superior duty cycle operation features more than ever.



Bigger Line Pull and Higher Lifterane Capacities

According to bigger line pull shown below, and higher lifterane capacities, a good performance to just lift bucket off ground quickly under bucket application, and to extract casing tube driven by casing driver into soil for bored pile can be done. And, it is possible to perform a pick-and-carry of casing driver of 2m dia. class even in a case of SCX800HD.

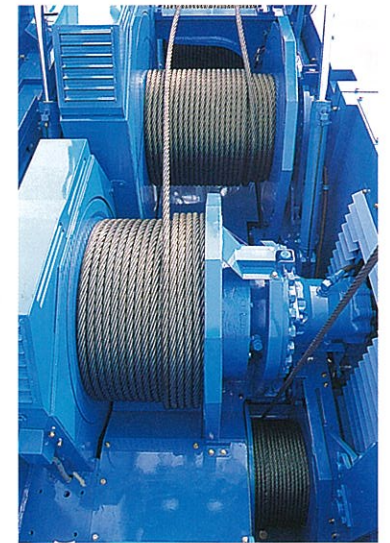

Higher Single Rope Line Speed

As well as bigger line pull and higher lifterane capacities, to perform a high efficient works, higher single rope line speed is each designed shown below with bigger engine horse power.

Line pull/line speed/engine data

	SCX800HD	SCX900HD-1	SCX1200HD	SCX2000HD
Max. starting line pull	215kN	245kN	309kN	309kN
Clamshell rating	10.0t	12.5t	15.0t	15.0t
Max. line speed	120m/min	100m/min	95m/min	95m/min
Engine rated output	184kW	235kW	353kW	353kW

Note: In case of lifterane application, max. allowable load under single part line is respectively 11.0t for SCX800HD and 13.5t for SCX900HD-1 while no difference from clamshell rating for SCX1200HD/SCX2000HD.

Cable dia. data

	SCX800HD	SCX900HD-1	SXC1200HD	SCX2000HD
Front main drum	φ26mm	φ28mm	φ32mm	φ32mm
Rear main drum	φ26mm	φ28mm	φ32mm	φ32mm
3rd drum	φ26mm	φ22.4mm	φ22.4mm	—

Larger Brake and Clutch with A Forced-air Cooling System

To let the machine have a good characteristic to perform continuous and long-time heavy duty operations certainly with no extreme increase of brake and clutch drum surface temperature, singular larger brake and clutch drums are each designed on two main operating drums together with a forced-air cooling system of air-blow type as standard.



SCX800HD

SC Controller Features A High Operation Ease



Thanks to unique SC controller, an easy-precise-minute control of engine rpm and pump discharge is really possible from minimum to maximum by simply twisting the grip at the same time.

Armchair Control Station

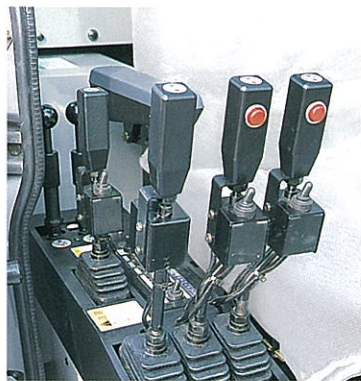

Single axis armchair control levers provide a good, easy and comfortable operation.

※Photo shows the case with optional 3rd drum control lever.

Hydraulically-assisted Drum Brakes

A newly developed hydraulically-assisted drum brake is each provided on two main operating drums to increase braking effect with less footing force. It results in significantly less operator fatigue during clamshell and hammergrab operations which very often require to brake the drum(s) as free-fall of bucket is required repeatedly.



※Photo shows the case with optional 3rd drum brake pedal.

Clean and Low Noise Engine

All of engines for four heavy duty machine models meet current EU Emission Regulations for Off-Road Diesel Engine - Stage 2, and Japanese Emission Standard for Diesel Construction Equipment - Stage 2. Also, these engines clear low noise level as defined by Ministry of Land, Infrastructure and Transport of Japan under the new noise measuring methods regulated by ISO.



SCX900HD-1

Plenty of Built-in Safety Device Provides Superior Safety Operation Features

A fully computerized automatic over-load preventing system of model SML-10 Load Moment Limiter functions alarming, automatic machine stop and emergency stop whenever over-loading, and its display panel indicates several kinds of present working and lifting conditions like actual lifting load. Also, newly designed display system greatly reduces setting and adjusting times for this kind of safety device.

Annunciating alarms help operator take a safety action whenever over-loading and boom over-hoisting/lowering. Also, as it is impossible to release both machine stop and alarm functions simultaneously, it prevents any accidents to be happened by release of both functions.

Dual boom over-hoist limiting device, as a further safety device for boom over-hoisting motion, attaches an additional limit switch onto boom backstops for redundant boom protection from a rapid boom over-hoist motion by hook over-hoisting under malfunction of hook over-hoist limiting device.

Hook hoisting speed slowdown device is optionally available, and it enables to perform hook over-hoist limiting motion safely furthermore in functional combination with standardized hook over-hoist limiting device.

Note:
These of safety devices shown above are applicable to liftcrane application except "Dual boom over-hoist limiting device".



Counterweight with Horizontally-split Design



※Photo shows SCX800HD.

It is able to minimize no. of vehicle as boom extension(s) can be loaded on counterweights after counterweights were onto trailer. Also, it enables to reduce the time for assembling and disassembling work of counterweight as their reversible stack is possible when their stack on ground is temporarily required.

Compact Transportation Width

For transportation ease, a compact overall width of basic machine is each designed as under:

- SCX800HD 3.20m (w/crawler side frames)
- SCX900HD-1 ... 3.50m (w/crawler side frames)
- SCX1200HD 3.39m (w/o crawler side frames)
- SCX2000HD ... 3.40m (w/o crawler side frames)

Notes:
1. Drawing shows the case of SCX1200HD.
2. The figure of 3.4m of SCX2000HD is dimension when operator's cab is swung.

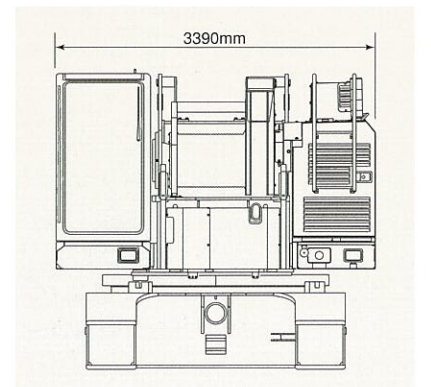

General Dimensions

General arrangements shown below are each under liftcrane application with basic boom and optional hook block of nominal capacity, and dimensional unit is millimeter.

SCX800HD

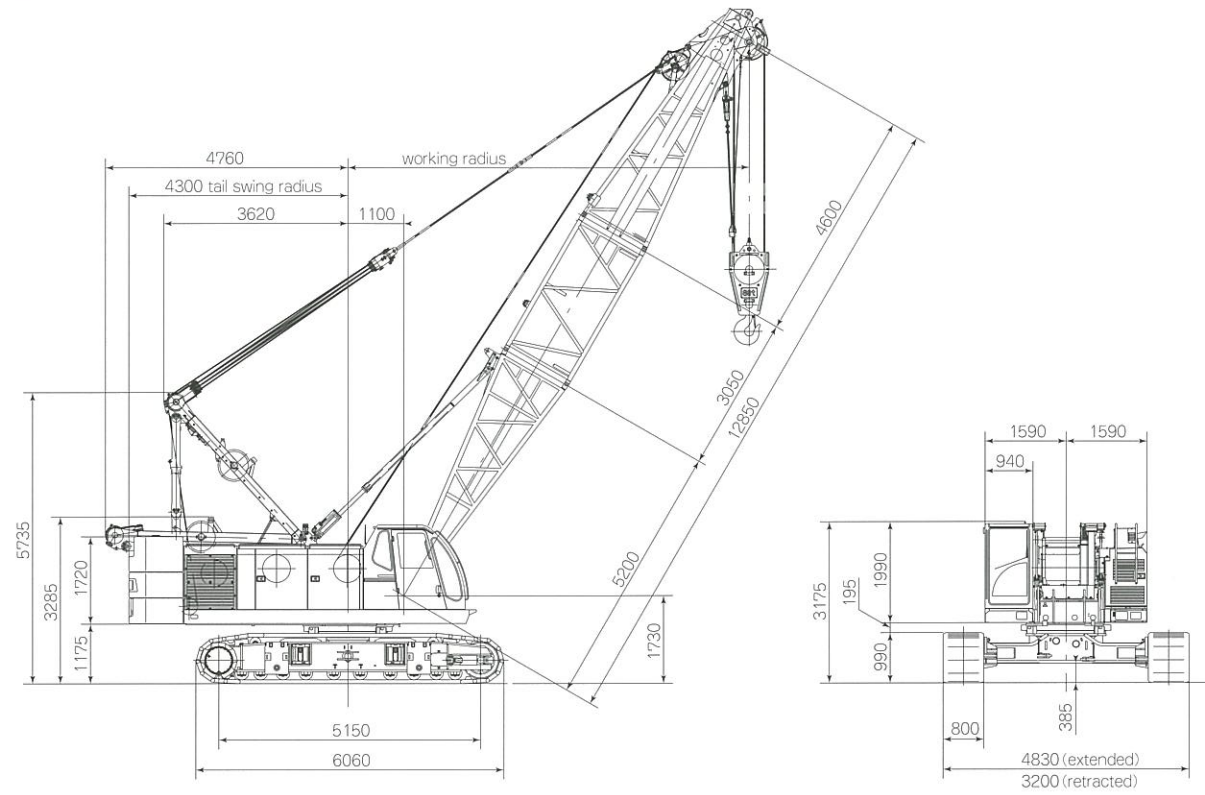

Note: The above drawing is shown with opt. 3rd drum.

General Dimensions

SCX1200HD

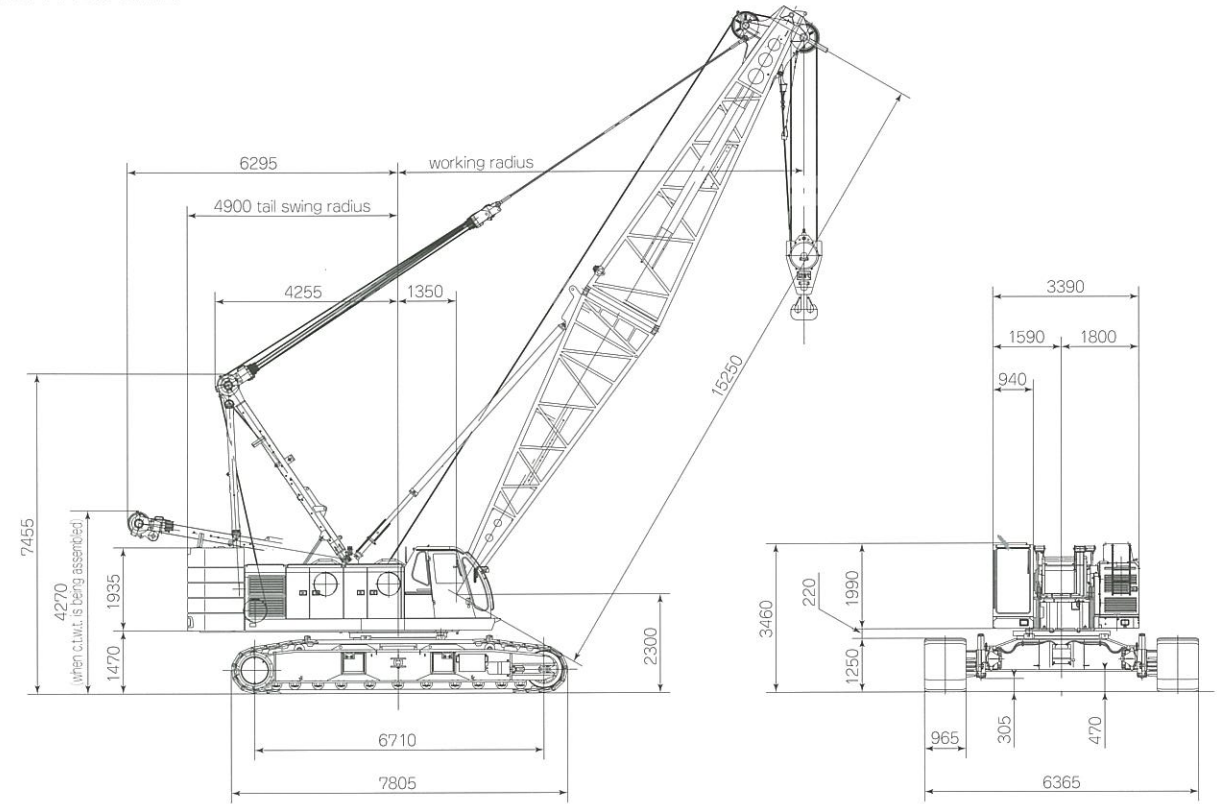

SCX900HD-1

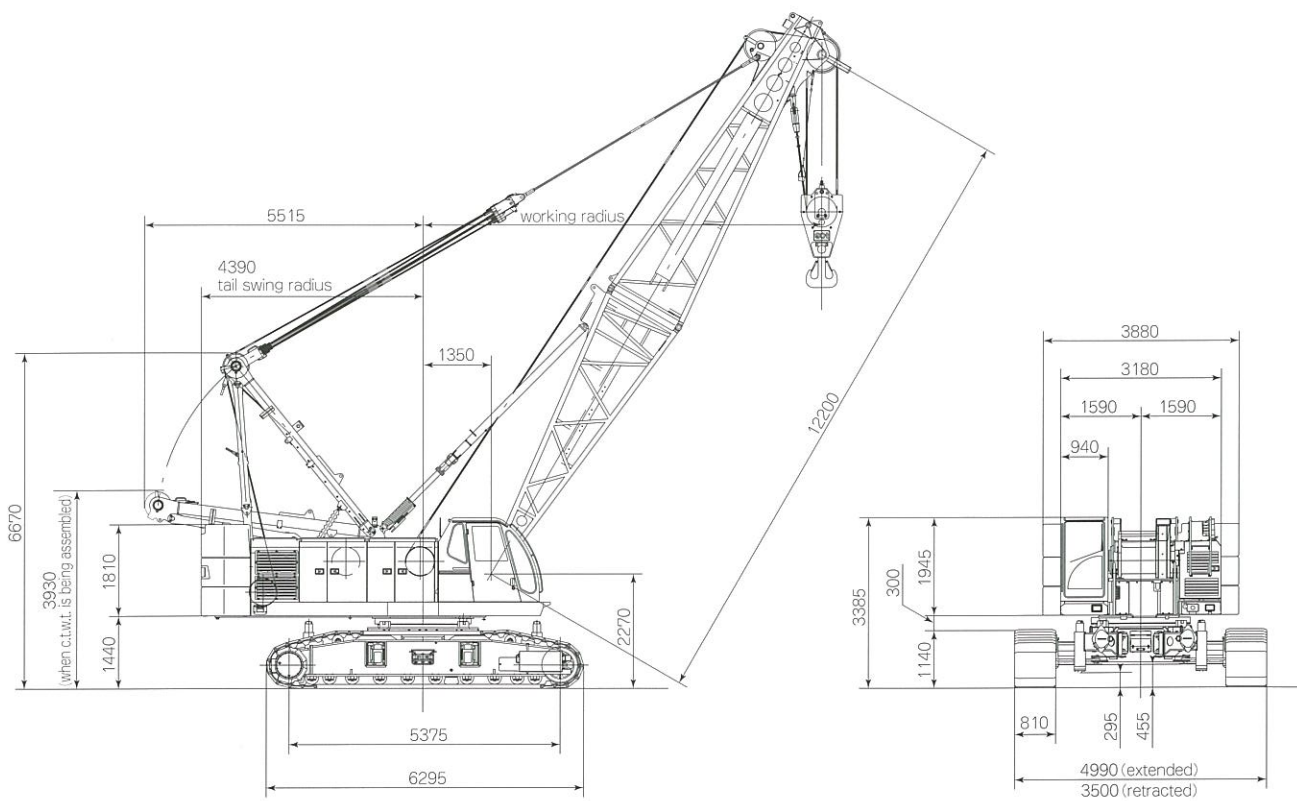

SCX2000HD

