

CASE

CONSTRUCTION

1150M CRAWLER DOZER



1150M LT

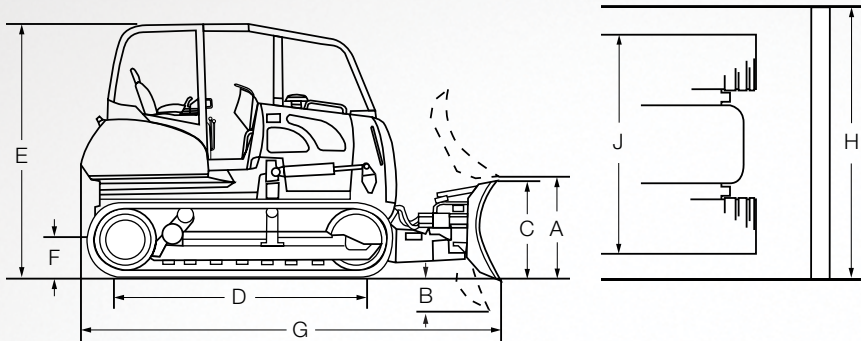

Line drawings are for illustrative purpose only and may not be exact representation of unit.

DIMENSIONS

1150M LT

A. Blade Lift Above Ground	3 ft. 9 in. (956 mm)
B. Blade Depth Below Ground	1 ft. 9 in. (539 mm)
C. Blade Height	3 ft. 8 in. (1 119 mm)
D. Length Of Track On Ground	8 ft. 6 in. (2 591 mm)
E. Height To Top Of Cab	9 ft. 8 in. (2 948 mm)
F. Ground Clearance	1 ft. 1 in. (331 mm)
G. Length, Blade Straight With Ripper	20 ft. 2 in. (6 150 mm)
H. Width, Blade Straight	10 ft. 0 in. (3 050 mm)
J. Width, Over Track	7 ft. 8 in. (2 344 mm)

SPECIFICATIONS	1150M LT
Engine	FPT F4HFE613F
Engine Cylinders	6
Displacement – in. ³ (L)	409 (6.7)
Net hp (kW) @ 2000 RPM	127 (96)
Emissions Certification	Tier 4 Interim (SCR)
Operating Weight* – lb. (kg)	31,134 (14 122)
Blade Width*	10 ft. 0 in. (3 050)
Blade Capacity – yd ³ (m ³)	3.75 (2.87)
Maximum Drawbar Pull** – lb. (kN)	48,000 (213.5)

NOTE: *Various blade options available for each track configuration.

**Measured using standard track chain. Increase travel speeds by 4% and reduce drawbar pull by 4% with the optional CELT track chain.

Protected by

ProCare

The 1150M comes standard with the industry's first all-in-one heavy machine support program that's as powerful as the equipment it protects – CASE ProCare. ProCare includes:

3K 3-year/3000-hr. Full-Machine Factory Warranty*.

We've got your back – for up to three full years!

3-year/3000-hr. Planned Maintenance.

Don't spend another dime for scheduled care from factory-trained CASE technicians.

3-year SiteWatch™ Subscription.

Telematics isn't a luxury, it's a necessity – and we've made it accessible to all.



Scan to learn more
or visit CaseCE.com/procare.

NOTE: *See your dealer for the complete terms of CNH's Warranty and Limitation of Liability, which contains certain limits and exclusions.



©2014 CNH Industrial America LLC. All rights reserved. CASE is a trademark registered in the United States and many other countries, owned by or licensed to CNH Industrial N.V., its subsidiaries or affiliates. CNH Industrial Capital is a trademark in the United States and many other countries, owned by or licensed to CNH Industrial N.V., its subsidiaries or affiliates. Printed in U.S.A.

Form No. CCE2014091150M
Replaces Form No. CCE2014061150M



SAFETY™
NEVER HURTS

Always read the Operator's Manual before operating any equipment. Inspect equipment before using it, and be sure it is operating properly. Follow the product safety signs and use any safety features provided.

NOTE: All engines meet current EPA emissions regulations.

NOTE: All specifications are stated in accordance with SAE Standards or Recommended Practices, where applicable.



Contains 10% post-consumer fiber

IMPORTANT: CASE Construction Equipment Inc. reserves the right to change these specifications without notice and without incurring any obligation relating to such change. Availability of some models and equipment builds vary according to the country in which the equipment is used. The illustrations and text may include optional equipment and accessories and may not include all standard equipment. Your CASE dealer/distributor will be able to give you details of the products and their specifications available in your area.



CASE construction equipment is biodiesel-friendly.