

D9T

Dozer



Engine

Engine Model	Cat® C18 ACERT™	
Emissions	U.S. EPA Tier 4 Final and EU Stage IV	
Net SAE J1349/ISO 9249	325 kW	436 hp

Weights

Operating Weight	48 361 kg	106,618 lb
Shipping Weight	36 316 kg	80,062 lb

D9T Dozer Specifications

Dimensions

All dimensions are approximate.

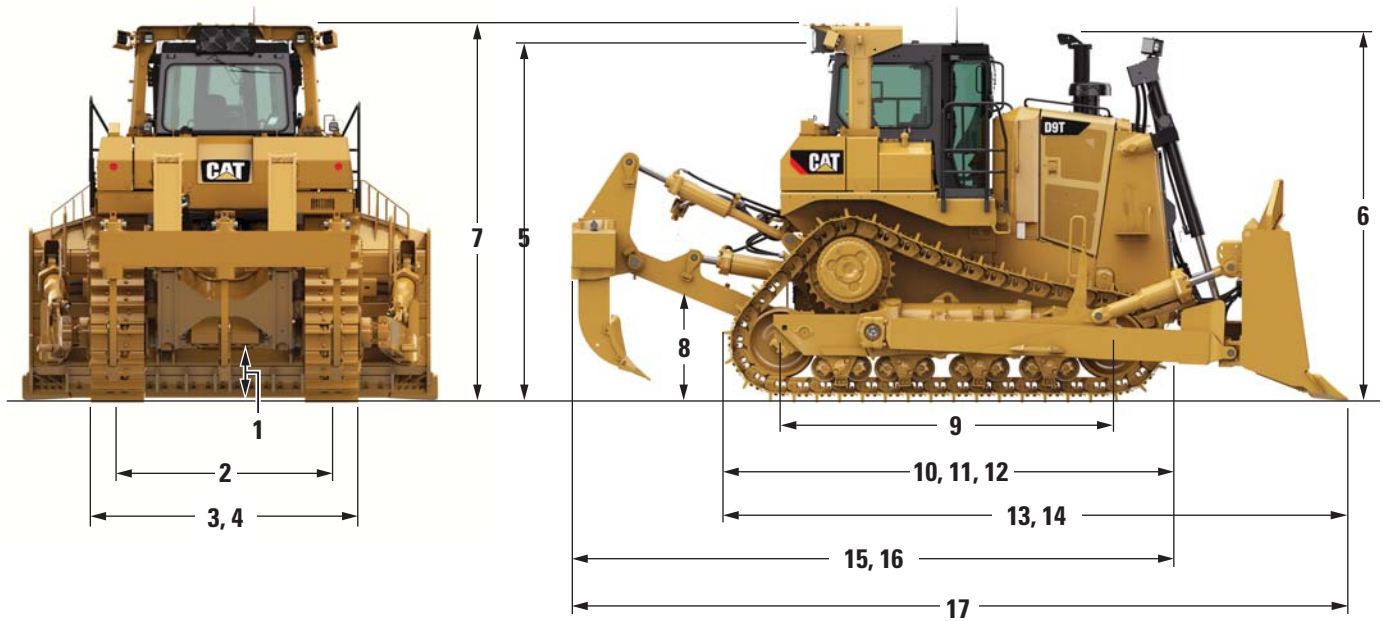

	D9T	
	mm	in
1 Ground Clearance*	596	23.4
2 Track Gauge	2250	88.6
3 Width without Trunnions (Standard Shoe)	2880	113.4
4 Width over Trunnions	3300	129.9
5 Height (FOPS Cab)*	3820	150.4
6 Height (Top of Stack)*	3997	157.4
7 Height (ROPS/Canopy)*	4000	157.5
8 Drawbar Height (Center of Clevis)*	763	30.0
9 Length of Track on Ground	3470	136.6
10 Overall Length Basic Tractor	4910	193.3
11 Length Basic Tractor with Drawbar	5180	204.0
12 Length Basic Tractor with Winch	5545	218.3
13 Length with SU-Blade**	6880	270.9
14 Length with U-Blade	6967	274.3
15 Length with Single-Shank Ripper	6529	257.0
16 Length with Multi-Shank Ripper	6538	257.4
17 Overall Length (SU-Blade/SS Ripper)	8230	324.0

*Includes grouser height for total dimensions on hard surfaces.

**Includes drawbar.

D9T Dozer Specifications

Engine – Tier 4 Final and Stage IV

Engine Model	Cat C18 ACERT	
Bore	145 mm	5.7 in
Stroke	183 mm	7.2 in
Displacement	18.1 L	1,106 in ³
Engine Power		
Gross SAE J1995*	350 kW	469 hp
ISO 14396	343 kW	460 hp
Net Power SAE J1349/ISO 9249	325 kW	436 hp

*Excludes all fan losses.

- Engine ratings apply at 1,800 rpm.
- Net power advertised is the power available at the flywheel when the engine is equipped with air cleaner, muffler, alternator, fan, and engine emissions controls as required.
- Ultra low sulfur diesel (ULSD) and low ash oil (CJ-4) are required.
 - Diesel Exhaust Fluid (DEF) that meets ISO-22241 specifications is required.

Weights

Operating Weight	48 361 kg	106,618 lb
Shipping Weight	36 316 kg	80,062 lb

- D9T Operating Weight includes hydraulic controls, blade tilt cylinder, coolant, lubricants, full fuel tank, ROPS, FOPS cab, SU-Blade, Single-Shank Ripper, 610 mm (24 in) ES shoes, and operator.
- D9T Shipping Weight includes base machine chassis with cab, pivot shaft, roller frames, track and ROPS.

Transmission

1 Forward	3.9 km/h	2.4 mph
2 Forward	6.8 km/h	4.2 mph
3 Forward	11.7 km/h	7.3 mph
1 Reverse	4.7 km/h	2.9 mph
2 Reverse	8.4 km/h	5.2 mph
3 Reverse	14.3 km/h	8.9 mph
1 Forward – Drawbar Pull	716 500 N	161,000 lbf
2 Forward – Drawbar Pull	400 500 N	90,000 lbf
3 Forward – Drawbar Pull	222 500 N	50,000 lbf

Hydraulic Controls

Pump Type	Piston-type pump geared from flywheel	
Pump Output (Steering)	387 L/min	102 gal/min
Pump Output (Implement)	226 L/min	60 gal/min
Tilt Cylinder Rod End Flow	140 L/min	37 gal/min
Tilt Cylinder Head End Flow	188 L/min	50 gal/min
Lift Cylinder Relief Valve Setting	26 200 kPa	3,800 psi
Tilt Cylinder Relief Valve Setting	19 300 kPa	2,800 psi
Ripper (Lift) Relief Valve Setting	26 200 kPa	3,800 psi
Ripper (Pitch) Relief Valve Setting	26 200 kPa	3,800 psi
Steering System Pressure	40 500 kPa	5,875 psi
Tank Capacity	89 L	23.5 gal

- Steering Pump output measured at 1,800 rpm and 30 000 kPa (4,351 psi).
- Implement Pump output measured at 1,800 rpm and 20 000 kPa (2,900 psi).
- Electro-hydraulic pilot valve assists operations of ripper and dozer controls. Standard hydraulic systems includes four valves.
- Complete system consists of pump, tank with filter, oil cooler, valves, lines, linkage and control levers.

Undercarriage

Shoe Type	Extreme Service	
Width of Shoe	610 mm	24 in
Shoes/Side	43	
Grouser Height	84 mm	3.3 in
Pitch	240 mm	9.4 in
Ground Clearance	596 mm	23.5 in
Track Gauge	2250 mm	88.6 in
Length of Track on Ground	3470 mm	136.6 in
Ground Contact Area	4.24 m ²	6569 in ²
Track Rollers/Side	8	
Number of Carrier Rollers	1 per side (optional)	

- Positive Pin Retention Track.

Service Refill Capacities

Fuel Tank	821 L	217 gal
DEF Tank	36 L	9.5 gal
Cooling System	98 L	25.9 gal
Engine Crankcase*	37 L	9.7 gal
Power Train	164 L	43.3 gal
Final Drives (each)	15 L	3.9 gal
Roller Frames (each)	45 L	11.9 gal
Pivot Shaft Compartment	30 L	7.9 gal
Hydraulic Tank Oil (only)	89 L	23.5 gal

*With oil filters.

Winches

Winch Model	PA 140VS	
Weight*	1790 kg	3,950 lb
Oil Capacity	15 L	4 gal
Increased Tractor Length	557 mm	21.9 in
Drum Width	320 mm	12.6 in
Wire Cable Diameter		
Recommended	28 mm	1.13 in
Optional	32 mm	1.25 in
Maximum drum capacity		
Recommended Cable Length	78 m	257 ft
Optional Cable Length	62 m	204 ft
Wire Cable Ferrule Size – Outside Diameter	60 mm	2.4 in
Wire Cable Ferrule Size – Length	70 mm	2.8 in

*Weight shown is base winch only. Does not include mounting arrangement, control arrangement, oil, or wire rope.
With counterweight: 3700 kg (8,150 lb).

- Variable speed, hydraulically driven, dual braking system, three-roller fairlead.

Standards

ROPS/FOPS

- ROPS (Rollover Protective Structure) offered by Caterpillar for the machine meets ROPS criteria SAE J1040 May 94, ISO 3471:1994.
- FOPS (Falling Object Protective Structure) meets ISO 3449:2005 Level II.

Sound

North America

- The declared dynamic operator sound pressure level is 76 dB(A) when “ISO 6396:2008” is used to measure the value for an enclosed cab. The measurement was conducted at 70% of the maximum engine cooling fan speed. The sound level may vary at different engine cooling fan speeds. The cab was properly installed and maintained. The measurement was conducted with the cab doors and the cab windows closed.
- The declared exterior sound power level is 114 dB(A) when the value is measured according to the dynamic test procedures and the conditions that are specified in “ISO 6395:2008.” The measurement was conducted at 70% of the maximum engine cooling fan speed. The sound level may vary at different engine cooling fan speeds.

Europe

- The declared dynamic operator sound pressure level is 74 dB(A) when “ISO 6396:2008” is used to measure the value for an enclosed cab. The measurement was conducted at 70% of the maximum engine cooling fan speed. The sound level may vary at different engine cooling fan speeds. The cab was properly installed and maintained. The measurement was conducted with the cab doors and the cab windows closed.
- The declared exterior sound power level is 113 dB(A) when the value is measured according to the dynamic test procedures and the conditions that are specified in “ISO 6395:2008.” The measurement was conducted at 70% of the maximum engine cooling fan speed. The sound level may vary at different engine cooling fan speeds.

D9T Dozer Specifications

D9T Bulldozer

Tag link dozer coupling brings blade closer for better balance and control.

Blade		9SU	9U
Blade capacity (SAE J1265)	m ³	13.5	16.4
	yd ³	17.7	21.4
Width with blade (over end bits)	mm	4310	4650
	in	169.7	183.1
Blade height	mm	1934	1934
	in	76.1	76.1
Maximum digging depth	mm	606	606
	in	23.9	23.9
Ground clearance at full lift	mm	1422	1422
	in	56	56
Maximum tilt	mm	940	1014
	in	37	39.9
Weight* (without hydraulic controls)	kg	6863	7388
	lb	15,130	16,288
Total operating weight** (with blade and single-shank ripper)	kg	48 361	48 956
	lb	106,618	107,929

* Includes blade installation arrangement, blade tilt cylinder, and blade lift cylinders.

** Total operating weight includes hydraulic controls, blade tilt cylinder, coolant, lubricants, full fuel tank, ROPS, FOPS cab, blade, single-shank ripper, 610 mm (24 in) ES shoes, and operator.

Ripper

Redesigned ripper frame for improved visibility to ripper tip. Hydraulic tip adjustment cylinders vary shank angle to aid penetration and help lift and shatter rock.

		Adjustable Parallelogram	
		Single-shank standard/deep	+ Multi-shank
Overall beam width	mm	—	1330
	in	—	52.4
Maximum penetration force (shank vertical)	kN	158/172	154
	lbf	35,520/38,667	34,621
Maximum penetration (standard tip)	mm	1231/1727	798
	in	48.5/68	31.4
Pryout force (multi-shank ripper with one tooth)	kN	332/331	361
	lbf	74,637/74,412	81,156
Maximum clearance raised (under tip, pinned in bottom hole)	mm	882/817	879
	in	34.7/32.2	34.6
Number of shank holes		3/3	2
Weight (with one shank)	kg	4293/4420	4153
	lb	9,464/9,744	9,156
with 9SU blade and ripper			
Total operating weight*	kg	48 361	48 221
	lb	106,618	106,309

* Total operating weight includes hydraulic controls, blade tilt cylinder, coolant, lubricants, full fuel tank, ROPS, FOPS cab, SU-blade, ripper, 610 mm (24 in) ES shoes, and operator.

+ Includes (1) shank, add 347 kg (765 lb) for each additional shank.

Note: Single-shank ripping arrangement weight includes pin puller.

Standard Equipment

Standard equipment may vary. Consult your Cat dealer for details.

ELECTRICAL

- Alternator, 150-amp
- Back-up alarm
- Batteries (two), 12-volt, 200 amp-hour
- Converter, 12-volt, 10 amp and 20 amp
- Diagnostic connector
- Horn, forward warning
- Light, engine compartment
- Lighting system, six halogen and two LED
- Starting receptacle

OPERATOR ENVIRONMENT

- Armrest, adjustable
- Cab, FOPS
- Cab heater
- Deactivation switch, hydraulic controls
- Decelerator pedal
- Differential steer, power turn
- Governor switch, electronic
- Hydraulic system, electronically controlled for bulldozer and ripper control
- Information display – multi-color
- Mirror, rearview
- MP3/IPOD ready
- Radio ready, entertainment
- ROPS mounted air conditioner
- ROPS rollbar
- Seat
 - Cloth, air suspension
- Seat belt, retractable 76 mm (3 in)
- Steering and transmission control
- Wipers, intermittent low and high speeds

POWER TRAIN

- Aftercooler, air-to-air
- Air filter, with precleaner
- Aluminum bar plate radiator, 6 fpi
- C18 with ACERT Technology, Tier 4 Final and Stage IV
 - 24-volt electric start
 - Clean Emissions Module
- Coolant, extended life
- Shift management
 - Advanced Productivity Electronic Control System (APECS)
 - Enhanced AutoShift (EAS)
- Engine idle shutdown timer
- Ether starting aid, automatic
- Fast fuel system
- Fuel priming pump, key-on, electric
- High speed oil change system, engine and power train
- Muffler
- Parking brake, electronic
- Prescreener
- Separator, water/fuel
- Three planet, double-reduction planetary final drives
- Torque converter
- Transmission, electronic control (ECPC), (3F/3R speeds)

SAFETY AND SECURITY

- Anchorage points
- Fender guard rails
- Heavy duty steps and handles
- Operator Not Present Monitor System
- Seat belt warning system
- Slope and side-slope monitor

UNDERCARRIAGE

- Equalizer bar end pin grease fittings, remote
- Rollers and idlers, lifetime lubricated
- Sprocket rim segments, replaceable
- Suspension-type undercarriage, eight-roller tubular track roller frame
- Three bolt idler caps
- Track adjusters, hydraulic
- Track guides
- Two-piece master links

OTHER STANDARD EQUIPMENT

- Automated Blade Assist ready (for dual tilt)
- CD ROM parts book
- Ecology drains
- Engine enclosure
- Fluid sampling ports
- Grade control ready
- Ground level service center
- Product Link (Satellite)
- Vandalism protection (eight caplocks)
- VIMS 3G