

# D3K2

Track-Type Tractor



## Engine

Engine Model\* Cat® C4.4 ACERT™

## Rated Net Power at 2,200 rpm

SAE J1349 59.7 kW 80 hp

ISO 9249/EEC 80/1269 59.7 kW 80 hp

## Weights

Operating Weight – XL 7958 kg 17,544 lb

Operating Weight – LGP 8403 kg 18,525 lb

Operating Weight – LGP, 762 mm (30 in) 8609 kg 18,980 lb

\*Engine meets U.S. EPA Tier 4 Interim/EU Stage IIIB/Japan MLIT Step 4 emission standards.

# D3K2 Track-Type Tractor Specifications

## Engine

Engine model	Cat C4.4 ACERT	
Rated Net Power @ 2,200 rpm		
SAE J1349	59.7 kW	80 hp
ISO 9249/EEC 80/1269	59.7 kW	80 hp
Bore	105 mm	4.13 in
Stroke	127 mm	5 in
Displacement	4.4 L	269 in <sup>3</sup>

- Ratings at 2,200 rpm.
- Net power advertised is the power available at the flywheel when engine is equipped with fan, air cleaner, muffler and alternator.
- No derating required up to 3000 m (9,843 ft) altitude.

## Weights

Operating weight – XL	7958 kg	17,544 lb
Operating weight – LGP	8403 kg	18,525 lb
Operating Weight – LGP, 762 mm (30 in)	8609 kg	18,980 lb

- Specifications shown are for machine equipped with dozer blade, canopy ROPS, back-up alarm, operator, coolant, lubricants and full fuel tank.

## Drawbar

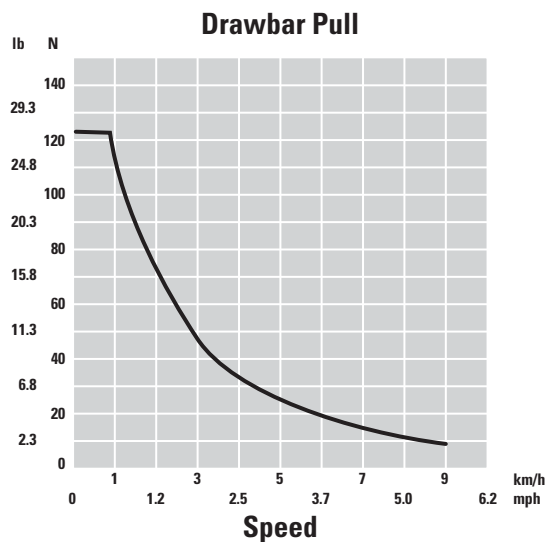

## Transmission

Drive pumps	2	
Track motors	2	
Relief valve settings	47 700 kPa	6,918 psi
Maximum travel speed – forward	9 km/h	5.6 mph
Maximum travel speed – reverse	10 km/h	6.2 mph

- Dual-path, closed loop hydrostatic drive provides infinitely variable speeds from 0-9 km/h (0-5.6 mph) forward and 0-10 km/h (0-6.2 mph) reverse.
- Full-flow filtering of hydrostatic charge system oil.
- Drive pumps: two variable-displacement, slipper-axial piston pumps mounted tandem-style to engine flywheel housing.
- Track motors: two variable-displacement, link-type piston motors.

## Service Refill Capacities

Fuel tank	195 L	51.5 gal
Crankcase and filter	11 L	2.91 gal
Final drives, XL (each side)	10 L	2.6 gal
Final drives, LGP (each side)	10 L	2.6 gal
Cooling system	22.4 L	5.92 gal
Transmission/hydraulic tank	59.5 L	15.7 gal

## Hydraulic Controls

Pump output	73.5 L/min	19.4 gal/min
Relief valve setting	20 600 kPa	2,988 psi

- Pump output ratings at 2,150 rpm and 6895 kPa (1,000 psi).
- Control positions:
  - Lift cylinders – raise, hold, lower, float.
  - Tilt cylinders – left, hold, right.
  - Angle cylinders – left, hold, right.
  - Ripper cylinders – raise, hold, lower.

## Final Drive

- Features:
- Double-reduction planetary gear set.
  - Mounted independently of track frames to isolate them from machine weight and ground-induced shock loads.

## Steering and Braking

- Features:
- Full powerturn.
  - Counter-rotation.
  - Single lever steering, speed and direction control.
  - Hydrostatic (dynamic) braking through machine drive system using transmission control lever, center brake pedal or decel pedal.

# D3K2 Track-Type Tractor Specifications

## Undercarriage

Number of rollers (each side)	6	
Number of shoes (each side) – SALT (Sealed and Lubricated Track) Undercarriage	43	
Number of shoes (each side) – SystemOne Undercarriage	38	
Shoe width – XL	406 mm	16 in
Shoe width – LGP	635 mm	25 in
Shoe width – LGP, 762 mm (30 in)	762 mm	30 in
Length of track on ground – XL	2248 mm	89 in
Length of track on ground – LGP	2248 mm	89 in
Length of track on ground – LGP, 762 mm (30 in)	2248 mm	89 in
Track gauge – XL	1495 mm	59 in
Track gauge – LGP	1725 mm	68 in
Track gauge – LGP, 762 mm (30 in)	1860 mm	73 in
Ground contact area – XL	18 254 cm <sup>2</sup>	2,829 in <sup>2</sup>
Ground contact area – LGP	28 550 cm <sup>2</sup>	4,425 in <sup>2</sup>
Ground contact area – LGP, 762 mm (30 in)	34 452 cm <sup>2</sup>	5,340 in <sup>2</sup>
Ground pressure – XL	42.8 kPa	6.2 psi
Ground pressure – LGP	30.0 kPa	4.2 psi
Ground pressure – LGP, 762 mm (30 in)	24.8 kPa	3.6 psi

- Hydraulic track adjusters.
- Box section track roller frames.
- Bolt-on rear track guiding guards.
- Full length recoil guarding with sprocket guards and wipers.
- Master link – SystemOne and SALT.
- Single-grouser shoes.
- Segmented sprocket (SALT).
- Sealed and lubricated rollers and idlers.

## Standards

Sound levels:	
ISO 6396:2008	77 dB(A)
SAE J1166 FEB2008	78 dB(A)
ROPS	SAE J397-OCT95, SAE J1040-MAY94, ISO 3471-94, ISO 3164-95
FOPS	SAE J231-JAN81, ISO 3449-92

## Ripper

Type	Parallelogram	
Number of shanks	3	
Maximum digging depth	337.5 mm	13.3 in
Maximum reach at ground line	766 mm	30.2 in
Maximum ground clearance under tip	448 mm	17.6 in
Overall width	1710 mm	67.3 in
Height	165 mm	6.5 in
Weight	554 kg	1,222 lb

## Winch

Weight	610 kg	1,345 lb
Winch drive	Hydrostatic	
Control	Hydraulic	
Speed	Variable	
Winch length	705 mm	27.76 in
Overall width	741 mm	29.2 in
Drum diameter	254 mm	10 in
Drum width	274 mm	10.8 in
Throat clearance	171.5 mm	6.75 in
Rope diameter – recommended	16 mm	0.63 in
Rope diameter – optional	19 mm	0.75 in
Drum capacity – recommended cable	113 m	371 ft
Drum capacity – optional cable	78 m	256 ft
Maximum line pull – bare drum	18 144 kg	40,000 lb
Maximum line pull – full drum	11 340 kg	25,000 lb
Maximum line speed – bare drum	40 m/min	131 ft/min
Maximum line speed – full drum	63 m/min	207 ft/min

- Infinitely variable line speed and line pull from 0 to maximum.
- Power in/power out, brake off, free spool (standard equipment).
- Single lever, low effort hydraulic control.
- Precise load control and speed modulation.
- Integral mounted drawbar.
- 3 roller fairlead available. Kit available to add a 4th roller.



## Dimensions

All dimensions are approximate.

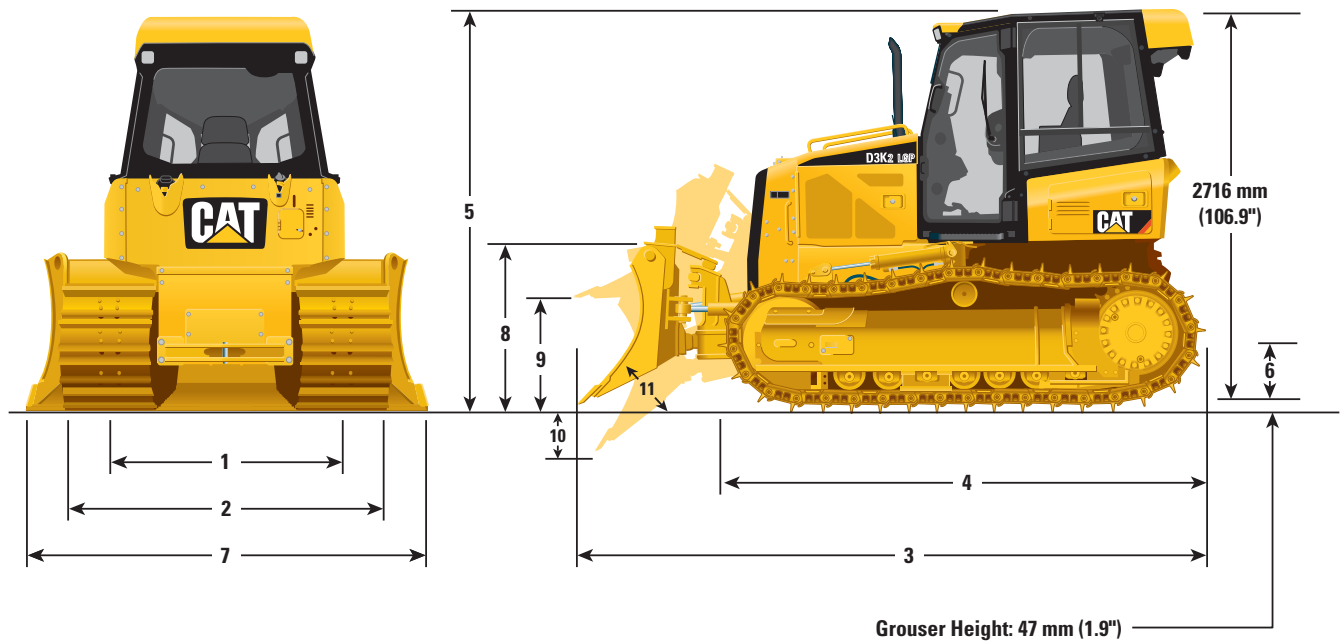

	XL		LGP		LGP, 762 mm (30 in)	
<b>1</b> Track gauge	1495 mm	58.9 in	1725 mm	67.9 in	1860 mm	73 in
<b>2</b> Width of tractor (standard shoes, no blade)	1901 mm	74.8 in	2360 mm	92.9 in	2411 mm	94.9 in
<b>3</b> Overall length (with blade)	4266 mm	168 in	4255 mm	167.6 in	4255 mm	167.6 in
<b>4</b> Length of basic tractor (without blade)	3275 mm	128.9 in	3275 mm	128.9 in	3275 mm	128.9 in
<b>5</b> Tractor height	2763 mm	108.8 in	2763 mm	108.8 in	2763 mm	108.8 in
<b>6</b> Ground clearance	332 mm	13 in	332 mm	13 in	332 mm	13 in

BLADE	XL		Intermediate		LGP	
<b>7</b> Blade width	2646 mm	104.2 in	2921 mm	115 in	3149 mm	124 in
<b>8</b> Blade height	910 mm	35.8 in	860 mm	33.9 in	860 mm	33.8 in
<b>9</b> Blade lift height	730 mm	28.7 in	743 mm	29.3 in	730 mm	28.7 in
<b>10</b> Digging depth	573 mm	22.5 in	573 mm	22.5 in	573 mm	22.5 in
<b>11</b> Blade cutting edge angle, adjustable	52° to 58°		52° to 58°		52° to 58°	
Maximum tilt	368 mm	14.5 in	448 mm	17.7 in	438 mm	17.2 in
Maximum angle (either side)	25°		25°		25°	
Blade width at maximum angle	2417 mm	95.2 in	2669 mm	105.1 in	2874 mm	113.1 in
Blade capacity (SAE)	1.52 m <sup>3</sup>	1.99 yd <sup>3</sup>	1.50 m <sup>3</sup>	1.96 yd <sup>3</sup>	1.66 m <sup>3</sup>	2.17 yd <sup>3</sup>