

# D6T

## Track-Type Tractor



### Engine

Engine Model	Cat® C9.3 ACERT™	
Emissions	U.S. EPA Tier 4 Final	
Engine Power (Maximum)		
SAE J1995	192 kW	257 hp
ISO 14396	190 kW	255 hp
ISO 14396 (DIN)		258 hp

### Engine (continued)

Net Power (Rated)			
ISO 9249/SAE J1349	154 kW		207 hp
ISO 9249/SAE J1349 (DIN)			210 hp
Net Power (Maximum)			
ISO 9249/SAE J1349	180 kW		241 hp
ISO 9249/SAE J1349 (DIN)			244 hp

# D6T Track-Type Tractor Specifications

## Service Refill Capacities

Fuel Tank	411 L	108.7 gal
DEF Tank	17.1 L	4.5 gal
Cooling System	51 L	13.4 gal
Engine Crankcase	24.6 L	6.5 gal
Power Train	148.0 L	39.1 gal
Final Drives (each)	13.5 L	3.6 gal
Roller Frames (each)	25.0 L	6.6 gal
Pivot Shaft Compartment	5.0 L	1.3 gal
Hydraulic Tank	65.5 L	17.3 gal

## Hydraulic Controls – Pressures

Maximum Operating Pressures		
Non-VPAT	19 300 kPa	2,800 psi
VPAT	21 550 kPa	3,125 psi
Steering	40 000 kPa	5,800 psi
Relief Pressures		
Non-VPAT	21 700 kPa	3,150 psi
VPAT	24 400 kPa	3,540 psi

## Hydraulic Controls – Pump

Pump Output		
Fan	93 L/min	25 gal/min
Implement	205 L/min	54 gal/min
Steering	195 L/min	52 gal/min
Lift Cylinder Flow	205 L/min	54 gal/min
Tilt Cylinder Flow	110 L/min	29 gal/min
Ripper Cylinder Flow	205 L/min	54 gal/min
Angle Cylinder Flow – VPAT	190 L/min	50 gal/min

## Ripper

Type	Fixed Parallelogram	
Ramp Angle	26 degrees	
Pocket Spacing	1000 mm	39.4 in
Shank Gauge	2000 mm	78.8 in
Shank Section	74 mm × 175 mm	2.9 in × 6.9 in
Number of Pockets	3	
Overall Beam Width	2202 mm	87 in
Beam Cross Section	219 mm × 304 mm	8.8 in × 12 in
Maximum Clearance Raised (under tip)	514 mm	20.2 in
Maximum Penetration	457 mm	18.0 in
Maximum Penetration Force	65.6 kN	14,747 lb
Pryout Force	116.5 kN	26,190 lb
Weight		
With One Shank	1498 kg	3,302 lb
Each Additional Shank	73 kg	161 lb

## Weights

Operating Weight		
XL A	21 306 kg	46,791 lb
XL SU	20 985 kg	46,263 lb
XL VPAT	23 663 kg	52,167 lb
XW A	22 191 kg	48,922 lb
XW SU	21 788 kg	48,034 lb
XW VPAT	24 118 kg	53,170 lb
LGP S	22 902 kg	50,490 lb
LGP A	24 020 kg	52,954 lb
LGP VPAT	24 336 kg	53,651 lb
Shipping Weight		
XL A/SU	17 753 kg	39,138 lb
XL VPAT	21 394 kg	47,165 lb
XW A/SU	18 414 kg	40,596 lb
XW VPAT	20 793 kg	45,840 lb
LGP S/A	19 806 kg	43,664 lb
LGP VPAT	22 009 kg	48,521 lb

- Operating weight includes blade, lubricants, coolant, full fuel tank, standard track, ROPS/FOPS cab, drawbar and operator.
- Shipping weight includes blade lift cylinders (C-frame for VPAT), lubricants, coolant, ROPS/FOPS cab, standard track and 10% fuel.

# D6T Track-Type Tractor Specifications

## Blades

	6 SU – XL		6A – XL		6 VPAT – XL	
Capacity	5.55 m <sup>3</sup>	7.26 yd <sup>3</sup>	3.95 m <sup>3</sup>	5.17 yd <sup>3</sup>	4.64 m <sup>3</sup>	6.07 yd <sup>3</sup>
Width	3260 mm	10.7 ft	4160 mm	13.7 ft	3880 mm	12.8 ft
Height	1407 mm	4.6 ft	1151 mm	3.8 ft	1294 mm	4.2 ft
Digging Depth	501 mm	19.7 in	555 mm	21.8 in	792 mm	31.2 in
Ground Clearance	1180 mm	46.5 in	1112 mm	43.8 in	1053 mm	41.5 in
Maximum Tilt	812 mm	32.0 in	424 mm	16.7 in	410 mm	16.1 in
Weight	1338.0 kg	2,949.8 lb	1194.6 kg	2,633.6 lb	1669.5 kg	3,680.6 lb

	6 SU – XW		6A – XW		6 VPAT – XW	
Capacity	5.64 m <sup>3</sup>	7.38 yd <sup>3</sup>	4.35 m <sup>3</sup>	5.69 yd <sup>3</sup>	5.02 m <sup>3</sup>	6.57 yd <sup>3</sup>
Width	3560 mm	11.7 ft	4520 mm	14.8 ft	4160 mm	13.7 ft
Height	1407 mm	4.6 ft	1153 mm	3.8 ft	1294 mm	4.2 ft
Digging Depth	502 mm	19.7 in	541 mm	21.3 in	743 mm	29.3 in
Ground Clearance	1180 mm	46.5 in	1139 mm	44.8 in	1102 mm	43.4 in
Maximum Tilt	791 mm	31.2 in	424 mm	16.7 in	442 mm	17.4 in
Weight	1415.4 kg	3,120.4 lb	1299.6 kg	2,865.2 lb	1763.8 kg	3,888.4 lb

	6S LGP		6A – LGP		6 VPAT – LGP	
Capacity	3.79 m <sup>3</sup>	4.96 yd <sup>3</sup>	4.94 m <sup>3</sup>	6.46 yd <sup>3</sup>	5.02 m <sup>3</sup>	6.57 yd <sup>3</sup>
Width	4063 mm	13.3 ft	5070 mm	16.7 ft	4160 mm	13.7 ft
Height	1108 mm	3.6 ft	1150 mm	3.8 ft	1294 mm	4.2 ft
Digging Depth	590 mm	23.2 in	853 mm	33.6 in	743 mm	29.3 in
Ground Clearance	1094 mm	43.1 in	1004 mm	39.5 in	1102 mm	43.4 in
Maximum Tilt	735 mm	28.9 in	618 mm	24.3 in	442 mm	17.4 in
Weight	1189.7 kg	2,622.2 lb	1456.5 kg	3,211.0 lb	1763.8 kg	3,888.4 lb

# D6T Track-Type Tractor Specifications

## Winch

Winch Model	PA56	
Winch Drive	Mechanical	
Control	Mechanical	
Weight	1203 kg	2,652 lb
Oil Capacity	67 L	17.8 gal
Increased Tractor Length		
XL/XW	516 mm	20.4 in
LGP	365 mm	14.4 in
Drum Diameter	254 mm	10.0 in
Rope Diameter		
Recommended	22 mm	0.88 in
Optional	25 mm	1.00 in
Drum Capacity		
22 mm (0.88 in)	88 m	288.7 ft
25 mm (1.0 in)	67 m	219.8 ft
Cable Ferrule Size (O.D. × Length)	54 mm × 67 mm	2.1 in × 2.6 in
Maximum Bare Drum		
Line Pull*	40 700 kg	89,800 lb
Line Speed	39.6 m/min	130 ft/min
Maximum Full Drum		
Line Pull*	34 600 kg	76,300 lb
Line Speed	68.3 m/min	224 ft/min

\* Maximum line pull is lesser of calculated line pull at maximum tractor PTO output torque or catalog breaking strength of maximum optional size new IWRC IPS wire rope.

## Drive Train

Type	Mechanical
------	------------

## Standards

ROPS/FOPS	ROPS meets ISO 3471:2008, FOPS meets ISO 3449:2005 Level II
Brakes	Brakes meet the International Standard ISO 10265:2008
Cab	Meets appropriate standards as listed below

- The declared dynamic operator sound pressure level is 76 dB(A) when “ISO 6396:2008” is used to measure the value for an enclosed cab. The measurement was conducted at 70% of the maximum engine cooling fan speed. The sound level may vary at different engine cooling fan speeds. The cab was properly installed and maintained. The measurement was conducted with the cab doors and the cab windows closed. The cab was properly installed and maintained.
- **Sound Level Information for Machines in European Union Countries and in Countries that Adopt the “European Union Directives”** – The information below applies to only the machine configurations that have the “CE” mark on the Product Identification Plate.
- The declared dynamic operator sound pressure level is 75 dB(A) when “ISO 6396:2008” is used to measure the value for an enclosed cab. The measurement was conducted at 70% of the maximum engine cooling fan speed. The sound level may vary at different engine cooling fan speeds. The cab was properly installed and maintained. The measurement was conducted with the cab doors and the cab windows closed. The cab was properly installed and maintained.
- Hearing protection is recommended when operating with an open operator station and cab (when not properly maintained or doors/windows open) for extended periods or in noisy environment.
- The declared exterior sound power level is 111 dB(A) when the value is measured according to the dynamic test procedures and the conditions that are specified in “ISO 6395:2008.” The measurement was conducted at 70% of the maximum engine cooling fan speed. The sound level may vary at different engine cooling fan speeds.

# D6T Track-Type Tractor Specifications

## Dimensions

All dimensions are approximate.

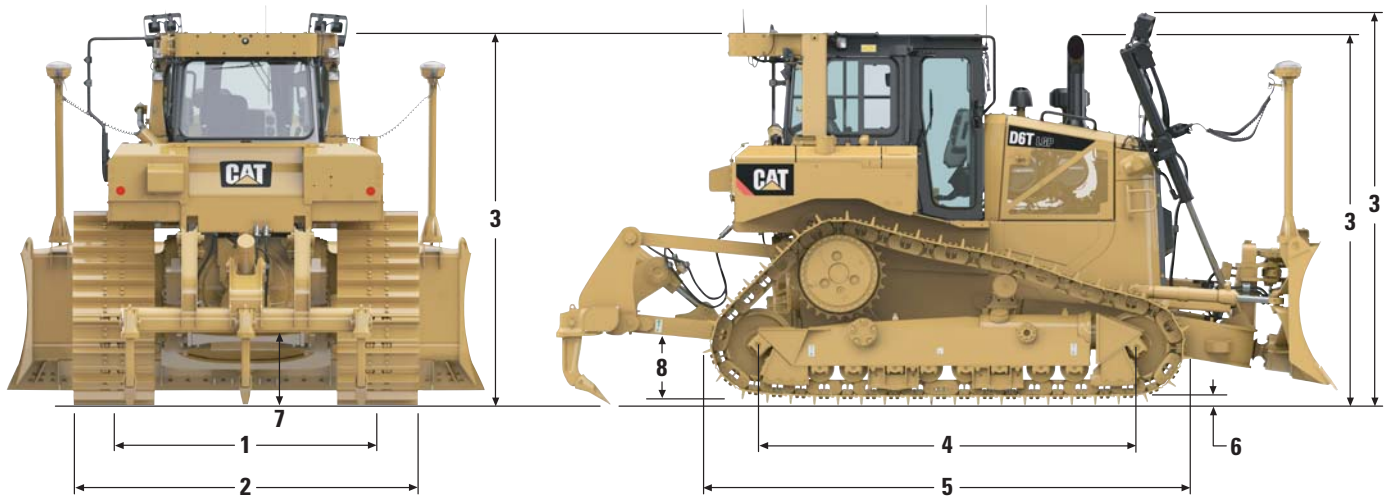

	XL		XW		LGP	
<b>1</b> Track gauge	1880 mm	6 ft 2 in	2032 mm	6 ft 8 in	2286 mm	7 ft 6 in
<b>2</b> Width of tractor over trunnions	2690 mm	8 ft 10 in	2944 mm	9 ft 8 in	3480 mm	11 ft 5 in
Width of tractor without trunnions (standard track)	2590 mm	8 ft 6 in	2792 mm	9 ft 2 in	3201 mm	10 ft 6 in
<b>3</b> Machine height** from tip of grouser:						
ROPS	3185 mm	10 ft 5 in	3185 mm	10 ft 5 in	3235 mm	10 ft 7 in
Premium Light Package	3341 mm	11 ft 0 in	3341 mm	11 ft 0 in	3097 mm	11 ft 1 in
Height to top of Sweeps (not shown)	3199 mm	10 ft 6 in	3199 mm	10 ft 6 in	3249 mm	10 ft 8 in
<b>4</b> Length of track on ground	2860 mm	9 ft 5 in	2860 mm	9 ft 5 in	3270 mm	10 ft 9 in
<b>5</b> Length of basic tractor	4250 mm	13 ft 9 in	4250 mm	13 ft 9 in	4546 mm	14 ft 11 in
With following attachments add:						
Drawbar	218 mm	9 in	218 mm	9 in	229 mm	9 in
Ripper Multi-shank (tip at ground line)	1395 mm	4 ft 7 in	1395 mm	4 ft 7 in	1259 mm	4 ft 2 in
Winch	570 mm	22 in	570 mm	22 in	435 mm	17 in
S Blade	—	—	—	—	947 mm	3 ft 1 in
SU Blade	1068 mm	3 ft 6 in	1068 mm	3 ft 6 in	—	—
A Blade	1007 mm	3 ft 4 in	1068 mm	3 ft 6 in	1305 mm	4 ft 4 in
A Blade angled approximately 25° for transport	837 mm	33 in	889 mm	35 in	989 mm	38.9 in
<b>6</b> Height of grouser	65 mm	2.6 in	65 mm	2.6 in	65 mm	2.6 in
<b>7</b> Ground clearance	372 mm	15 in	372 mm	15 in	406 mm	16 in
Oscillation at front idler	141 mm	5.5 in	137 mm	5.4 in	163 mm	6.4 in
Track pitch	203 mm	8 in	203 mm	8 in	203 mm	8 in
Number of shoes per side	41		41		45	
Track rollers/carrier rollers per side	7/1		7/1		8/1	
Standard shoe width (moderate service)	560 mm	22 in	760 mm	30 in	915 mm	36 in
Ground contact area (standard track)*	3.54 m <sup>2</sup>	5,489 in <sup>2</sup>	4.81 m <sup>2</sup>	7,449 in <sup>2</sup>	6.53 m <sup>2</sup>	10,122 in <sup>2</sup>
Ground pressure*	58.1 kPa	8.4 psi	44.5 kPa	6.4 psi	34.4 kPa	4.99 psi
<b>8</b> Drawbar height	576 mm	23 in	576 mm	23 in	626 mm	25 in
From ground face of shoe	511 mm	20 in	511 mm	20 in	561 mm	22 in

\*All dimensions above with SystemOne undercarriage. XL and XW with SU blade, LGP with S blade with no rear attachments unless otherwise specified and calculated per ISO 16754.

\*\*When Cat Grade Control 3D antennas are installed, overall machine height increases by approximately 82 mm/3.2 in.

# D6T Track-Type Tractor Specifications

## Dimensions

All dimensions are approximate.

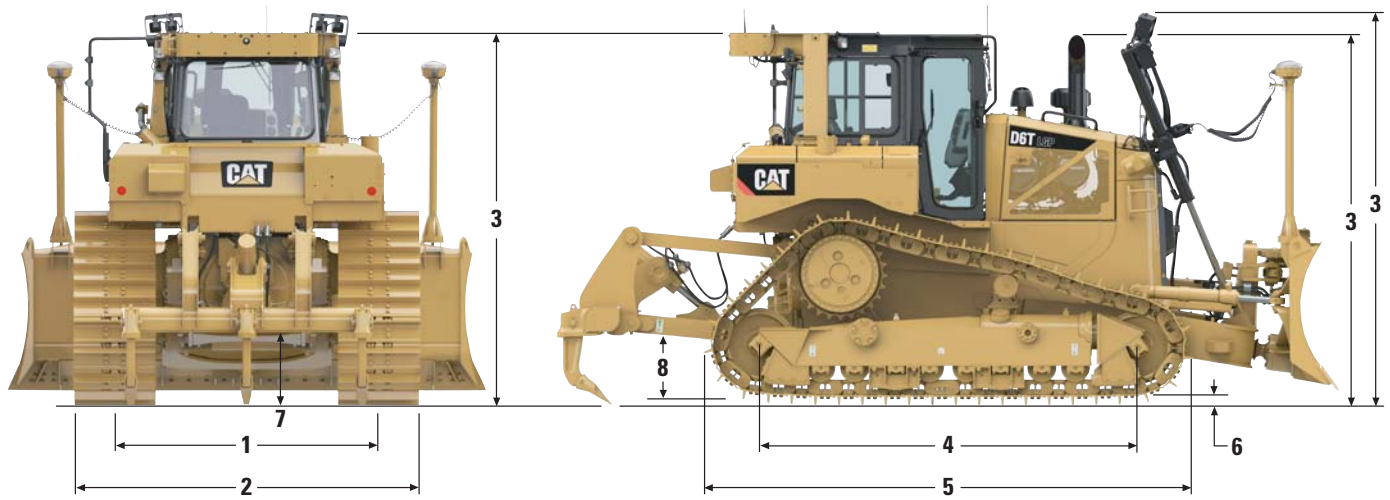

	XL VPAT		XW VPAT		LGP VPAT	
<b>1</b> Track gauge	2134 mm	7 ft 0 in	2286 mm	7 ft 6 in	2286 mm	7 ft 6 in
<b>2</b> Width of tractor over trunnions	—	—	—	—	—	—
Width of tractor without trunnions (standard track)	2717 mm	8 ft 11 in	2996 mm	9 ft 10 in	3143 mm	10 ft 4 in
<b>3</b> Machine height** from tip of grouser:						
ROPS	3185 mm	10 ft 5 in	3235 mm	10 ft 7 in	3235 mm	10 ft 7 in
Premium Light Package	3308 mm	10 ft 10 in	3358 mm	11 ft 1 in	3358 mm	11 ft 1 in
Height to top of Sweeps (not shown)	3199 mm	10 ft 6 in	3249 mm	10 ft 8 in	3249 mm	10 ft 8 in
<b>4</b> Length of track on ground	2860 mm	9 ft 5 in	3270 mm	10 ft 9 in	3270 mm	10 ft 9 in
<b>5</b> Length of basic tractor	4950 mm	16 ft 3 in	5086 mm	16 ft 8 in	5086 mm	16 ft 8 in
With following attachments add:						
Drawbar	218 mm	9 in	229 mm	9 in	229 mm	9 in
Ripper Multi-shank (tip at ground line)	1395 mm	4 ft 7 in	1259 mm	4 ft 2 in	1259 mm	4 ft 2 in
Winch	570 mm	22 in	435 mm	17 in	435 mm	17 in
S Blade	—	—	—	—	—	—
SU Blade	—	—	—	—	—	—
VPAT Blade	420 mm	1 ft 5 in	420 mm	1 ft 5 in	420 mm	1 ft 5 in
VPAT Blade angled approximately 25° for transport	670 mm	26.4 in	720 mm	28.3 in	720 mm	28.3 in
<b>6</b> Height of grouser	65 mm	2.6 in	65 mm	2.6 in	65 mm	2.6 in
<b>7</b> Ground clearance	372 mm	15 in	406 mm	16 in	406 mm	16 in
Oscillation at front idler	141 mm	5.5 in	163 mm	6.4 in	163 mm	6.4 in
Track pitch	203 mm	8 in	203 mm	8 in	203 mm	8 in
Number of shoes per side		41		45		45
Track rollers/carrier rollers per side		7/1		8/1		8/1
Standard shoe width (moderate service)	560 mm	22 in	710 mm	28 in	785 mm	31 in
Ground contact area (standard track)*	3.54 m <sup>2</sup>	5,489 in <sup>2</sup>	5.10 m <sup>2</sup>	7,909 in <sup>2</sup>	5.60 m <sup>2</sup>	8,684 in <sup>2</sup>
Ground pressure*	65.5 kPa	9.5 psi	46.4 kPa	6.7 psi	42.6 kPa	6.2 psi
<b>8</b> Drawbar height	576 mm	23 in	626 mm	25 in	626 mm	25 in
From ground face of shoe	511 mm	20 in	561 mm	22 in	561 mm	22 in

\*All dimensions above with SystemOne undercarriage. XL and XW with SU blade, LGP with S blade with no rear attachments unless otherwise specified and calculated per ISO 16754.

\*\*When Cat Grade Control 3D antennas are installed, overall machine height increases by approximately 82 mm/3.2 in.