

KOMATSU®

D65EXi-18 **D65PXi-18** Tier 4 Final Engine

CRAWLER DOZER

D65i



Photos may include optional equipment.

intelligent™
MACHINE CONTROL

NET HORSEPOWER

217 HP @ 1950 rpm
162 kW @ 1950 rpm

OPERATING WEIGHT

SIGMADOZER®
D65EXi-18: 45,780 lb 20810 kg
Straight Tilt Dozer
D65PXi-18: 48,620 lb 22100 kg
Power Angle Tilt Dozer
D65PXi-18: 50,420 lb 22960 kg

BLADE CAPACITY

SIGMADOZER®
D65EXi-18: 7.3 yd³ 5.6 m³
Straight Tilt Dozer
D65PXi-18: 4.8 yd³ 3.7 m³
Power Angle Tilt Dozer
D65PXi-18: 5.8 yd³ 4.4 m³

SPECIFICATIONS



FINAL DRIVES

Double-reduction final drive of spur and planetary gear sets to increase tractive effort and reduce gear tooth stresses for long final drive life. Segmented sprocket teeth are bolt-on for easy replacement.



SERVICE REFILL CAPACITIES

Fuel tank	415 ltr	109.6 U.S. gal
DEF tank	23.5 ltr	6.2 U.S. gal
Coolant	49 ltr	12.9 U.S. gal
Engine.....	30.5 ltr	8.1 U.S. gal
Torque converter, transmission, bevel gear, and steering system	48 ltr	12.7 U.S. gal
Final drive (each side)		
D65EXi-18 non PAT	16.5 ltr	4.4 U.S. gal
D65PXi-18	22 ltr	5.8 U.S. gal



HYDRAULIC SYSTEM

Closed-center load sensing system (CLSS) designed for precise and responsive control, and for efficient simultaneous operation.

Hydraulic control units:

All spool valves externally mounted beside the hydraulic tank.
Piston type hydraulic pump with capacity (discharge flow) of 248 ltr/min **65.5 U.S. gal/min** at rated engine rpm.

Relief valve setting 27.9 MPa 285 kg/cm² **4,050 psi**

Control valves:

Spool control valves for SIGMADOZER® or straight tilt dozer

 Positions: Blade lift Raise, hold, lower, and float
 Blade tilt Right, hold, and left
 Rear attachment.....Raise, hold, and lower

Spool control valves for Power Angle Tilt dozer

 Positions: Blade lift Raise, hold, lower, and float
 Blade tilt Right, hold, and left
 Blade angle Right, hold, and left
 Rear attachment.....Raise, hold, and lower

Hydraulic cylinders..... Double-acting, piston

	Number of cylinders	Bore	
		SIGMADOZER® Straight Tilt Dozer	Power Angle Power Tilt Dozer
Blade lift	2	85 mm 3.3"	90 mm 3.5"
Blade tilt	1	125 mm 4.9"	130 mm 5.1"
Blade angle	2	N/A	110 mm 4.3"
Ripper lift	1	125 mm 4.9"	125 mm 4.9"
Pitch angle	1	39° - 53°	52° - 58°

Hydraulic oil capacity (refill): 62 ltr **16.4 U.S. gal**

Ripper equipment (additional volume):

 Multi-shank ripper 7 ltr **1.8 U.S. gal**



DOZER EQUIPMENT

Blade capacities are based on the SAE recommended practice J1265.

Use of high tensile strength steel in moldboard for strengthened blade construction.

	Overall Length With Dozer mm ft.in	Blade Capacity m ³ yd ³	Blade Width x Height mm ft.in	Max. Lift Above Ground mm ft.in	Max. Drop Below Ground mm ft.in	Max. Tilt Adjustment mm ft.in	Weight Dozer equipment kg lb	Ground Pressure* kPa kg/cm ² psi
D65EXi-18	5490	5.61	3410 x 1425	1135	500	870	2390	55.8/0.57/ 8.13
SIGMADOZER®	18'0"	7.34	11'2" x 4'8"	3'9"	1'8"	2'10"	5,260	
D65PXi-18	5680	3.69	3970 x 1100	1130	535	890	2100	
Straight Tilt Dozer	18'8"	4.83	13'0" x 3'7"	3'8"	1'9"	2'11"	4,630	36.0/0.37/ 5.20
D65PXi-18	5790	4.42	4010 x 1235	1170	695	520	2990	
Power Angle Tilt Dozer	19'0"	5.78	13'2" x 4'1"	3'10"	2'3"	1'8"	6,590	46.4/0.47/ 6.73

*Ground pressure shows tractor, ROPS cab, full fluids, operator, standard equipment and applicable blade.



DIMENSIONS — OUTSIDE MOUNTED DOZER BLADE

	D65EXi-18 SIGMADOZER®	D65PXi-18 Straight Tilt Dozer
A	5490 mm 18'0"	5680 mm 18'8"
B	1880 mm 6'2"	2050 mm 6'9"
C	3330 mm 10'11" *	3330 mm 10'11" *
D	3085 mm 10'1"	3085 mm 10'1"
E	2970 mm 9'9"	3275 mm 10'9"
F	610 mm 24"	915 mm 36"
G	65 mm 2.6"	65 mm 2.6"

Ground clearance 415 mm **1'4"**

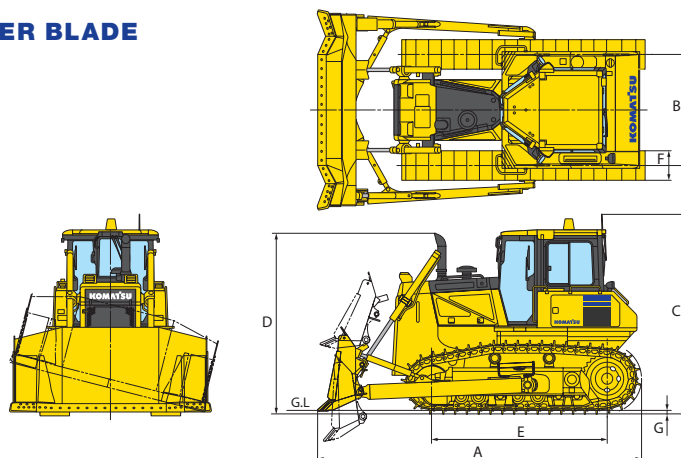

Shown with SIGMADOZER® single grouser shoe.



DIMENSIONS — PAT DOZER BLADE

	D65PXi-18 PAT Dozer
A	5790 mm 19'0"
B	2230 mm 7'4"
C	3330 mm 10'11" *
D	3085 mm 10'1"
E	3275 mm 10'9"
F	760 mm 30"
G	65 mm 2.6"
H	3670 mm 12'0"

Ground clearance 415 mm **1'4"**

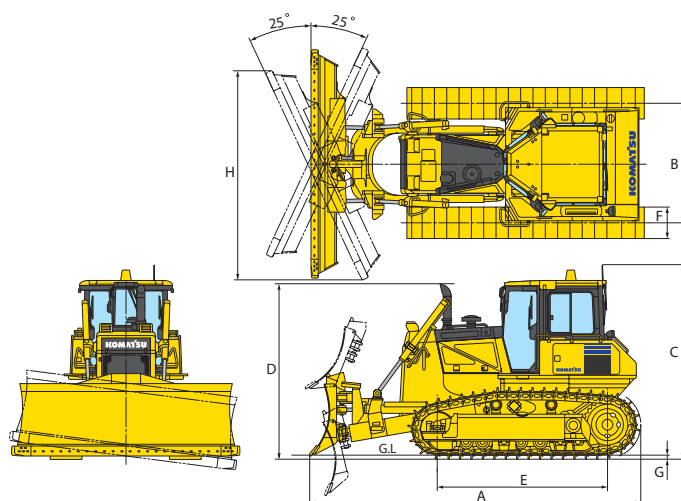

Shown with Power Angle Tilt dozer single grouser shoe.



OPERATING WEIGHT

Tractor weight:

Including ROPS cab, rated capacity of lubricant, hydraulic control unit, coolant, full fuel tank, operator, and standard equipment.

D65EXi-18 18420 kg **40,520 lb**

D65PXi-18 20000 kg **44,000 lb**

for PAT dozer

D65PXi-18 19970 kg **43,930 lb**

Operating weight:

Including SIGMADOZER® (EX) or straight tilt dozer (PX) or Power Angle Tilt dozer, ROPS cab, operator, standard equipment, rated capacity of lubricant, hydraulic control unit, coolant, and full fuel tank.

D65EXi-18 20810 kg **45,780 lb**

D65PXi-18 22100 kg **48,620 lb**

for PAT dozer

D65PXi-18 22960 kg **50,420 lb**