

# KOMATSU®

## D61EX-23

## D61PX-23

Tier 4 Interim Engine

D  
6  
1

### NET HORSEPOWER

168 HP @ 2200rpm

125 kW @ 2200rpm

### OPERATING WEIGHT

D61EX-23 17735 kg **39,099 lb**

D61PX-23 18660 kg **41,138 lb**

### BLADE CAPACITY

4.5–5.1 yd<sup>3</sup>

3.4–3.9 m<sup>3</sup>



PHOTOS MAY INCLUDE OPTIONAL EQUIPMENT



## ENGINE

Model..... Komatsu SAA6D107E-2\*  
 Type..... 4-cycle, water-cooled, direct injection  
 Aspiration..... Komatsu variable geometry Turbocharged, air-to-air aftercooled  
 Number of cylinders..... 6  
 Bore x stroke..... 107 mm x 124 mm **4.21" x 4.88"**  
 Piston displacement..... 6.69 ltr **408 in³**  
 Governor..... All-speed and mid-range, electronic  
 Horsepower  
     SAE J1995..... Gross 127 kW **170 HP**  
     (ISO 14396..... 126 kW **169 HP**)  
     ISO 9249 / SAE J1349..... Net 125 kW **168 HP**  
 Rated rpm..... 2200 rpm  
 Fan drive type..... Hydraulic  
 Lubrication system  
     Method..... Gear pump, force lubrication  
     Filter..... Full-flow  
 \*EPA Tier 4 Interim and EU stage 3B emissions certified



## HYDROSTATIC TRANSMISSION

Dual-path, hydrostatic transmission provides infinite speed changes up to 9.0 km/h **5.6 mph**. The variable capacity travel motors allow the operator to select the optimum speed to match specific jobs. Travel control lock lever and neutral switch.

Travel speed (quick shift mode)*	Forward	Reverse
<b>1st</b>	0-3.4 km/h <b>0-2.1 mph</b>	0-4.1 km/h <b>0-2.5 mph</b>
<b>2nd</b>	0-5.6 km/h <b>0-3.5 mph</b>	0-6.5 km/h <b>0-4.0 mph</b>
<b>3rd</b>	0-9.0 km/h <b>0-5.6 mph</b>	0-9.0 km/h <b>0-5.6 mph</b>

Travel speed (variable mode)	Forward	Reverse
	0-9.0 km/h <b>0-5.6 mph</b>	0-9.0 km/h <b>0-5.6 mph</b>

\*Quick shift speeds are adjustable in the monitor.

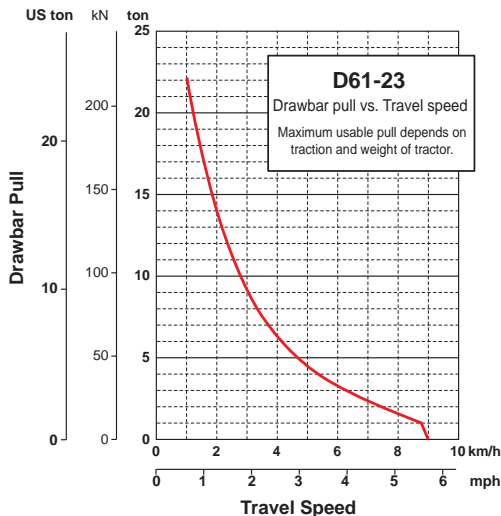

## FINAL DRIVES

In-shoe mounted axial piston type travel motors with integrated two-stage planetary gear reduction. Compact in-shoe mount reduces risk of damaged by debris. Bolt-on sprocket teeth for easy displacement.



## STEERING SYSTEM

Palm Command Control System (PCCS) joystick control for all directional movements. Pushing the joystick forward results in forward machine travel, while pulling it rearward reverses the machine. Simply tilt the joystick to the left or right to make a turn. Tilting the joystick fully to the left or right activates counter-rotation.

Hydrostatic Transmission (HST) provides smooth powerful turns. Fully electronic control enables smooth control that can be adjusted in the monitor. The PCCS utilizes shift buttons to increase and decrease speed.

Minimum turning radius\*  
 D61EX-23.....2.1 m **83"**  
 D61PX-23..... 2.3 m **91"**

\*As measured by track marks on the ground at pivot turn.



## UNDERCARRIAGE

Suspension..... Oscillating-type with equalizer bar and pivot shafts  
 Track roller frame..... Monocoque, large section, durable construction  
 Rollers and idlers..... Lubricated track rollers  
 Lubricated tracks

Parallel Link Undercarriage System (PLUS) with lubricated rotating bushings for extended system wear life and lower maintenance costs. Track tension is easily adjusted with grease gun.

	D61EX-23	D61PX-23
Number of track rollers (each side)	8	8
Type of shoes (standard)	Single grouser	Single grouser
Number of shoes (each side)	46	46
Grouser height	mm in 57.5 <b>2.3"</b>	57.5 <b>2.3"</b>
Shoe width (standard)	mm in 600 <b>24"</b>	860 <b>34"</b>
Ground contact area	cm²	54520
	in²	<b>4,836</b>
		<b>8,451</b>
Ground pressure (with dozer, ROPS cab)	kPa	55.7
	kgf/cm²	0.57
	psi	<b>8.08</b>
		<b>4.87</b>
Track gauge	mm ft.in 1900 <b>6'3"</b>	2130 <b>7'0"</b>
Length of track on ground	mm ft.in 3161 <b>10'5"</b>	3161 <b>10'5"</b>



## SERVICE REFILL CAPACITIES

Coolant..... 45 ltr **11.9 U.S. gal**  
 Fuel tank..... 372 ltr **98.3 U.S. gal**  
 Engine oil..... 27 ltr **7.2 U.S. gal**  
 Hydraulic tank..... 101 ltr **26.7 U.S. gal**  
 Final drive (each side)..... 8.1 ltr **2.2 U.S. gal**



## OPERATING WEIGHT

Tractor weight:

Including ROPS cab, U frame for power angle tilt dozer, rated capacity of lubricant, coolant, full fuel tank, operator, and standard equipment.

D61EX-23..... 16780 kg **36,999 lb**  
 D61PX-23..... 17500 kg **38,581 lb**

Operating weight:

Including Power Angle Tilt dozer, ROPS cab, operator, standard equipment, rated capacity of lubricant, hydraulic control unit, coolant, and full fuel tank.

D61EX-23..... 17735 kg **39,099 lb**  
 D61PX-23..... 18660 kg **41,138 lb**



## DIMENSIONS

	D61EX-23		D61PX-23	
A	3250 mm	<b>10'8"</b>	3860 mm	<b>12'8"</b>
B	435 mm	<b>1'5"</b>	515 mm	<b>1'8"</b>
C	1195 mm	<b>3'11"</b>	1155 mm	<b>3'9"</b>
D	1025 mm	<b>3'4"</b>	1025 mm	<b>3'4"</b>
E	580 mm	<b>1'11"</b>	580 mm	<b>1'11"</b>
F	3165 mm	<b>10'5"</b>	3165 mm	<b>10'5"</b>
G	5480 mm	<b>17'12"</b>	5480 mm	<b>17'12"</b>
H	3180 mm	<b>10'5"</b>	3180 mm	<b>10'5"</b>
I	57.5 mm	<b>2"</b>	57.5 mm	<b>2"</b>
J	1900 mm	<b>6'3"</b>	2130 mm	<b>7'0"</b>
K	600 mm	<b>2'0"</b>	860 mm	<b>2'10"</b>
L	2500 mm	<b>8'2"</b>	2990 mm	<b>9'10"</b>
M	2980 mm	<b>9'9"</b>	3530 mm	<b>11'7"</b>
N	6100 mm	<b>20'0"</b>	6220 mm	<b>20'5"</b>

Ground clearance ..... 390 mm **15"**

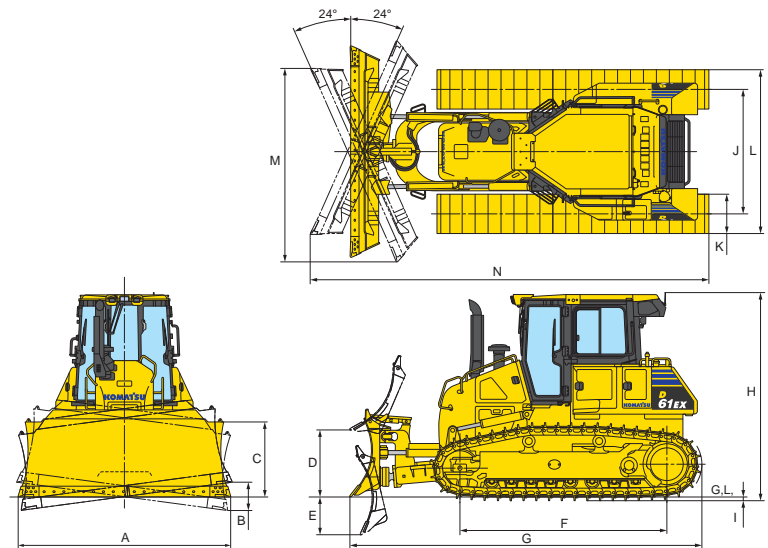

## HYDRAULIC SYSTEM

Closed-center Load Sensing System (CLSS) designed for precise and responsive control, and for efficient simultaneous operation.

Hydraulic control unit:

All spool control valves externally mounted remote to the hydraulic tank. Piston-type hydraulic pump with capacity (discharge flow) of 171 ltr/min **45 U.S. gal/min** at rated engine rpm.

Relief valve setting ..... 27.4 MPa 280 kg/cm<sup>2</sup> **3,974 psi**

Hydraulic cylinders..... Double-acting, piston type

	Number of cylinders	Bore
Blade lift	2	100 mm <b>4"</b>
Blade tilt	1	120 mm <b>5"</b>
Blade angle	2	110 mm <b>4"</b>

Hydraulic oil capacity (refill):

Power angle tilt dozer ..... 101 ltr **26.7 U.S. gal**

Control valves:

3-spool control valve for Power Angle Tilt dozer

Positions:

Blade lift ..... Raise, hold, lower, and float

Blade tilt ..... Right, hold, and left

Blade angle ..... Right, hold, and left

Additional control valve required for ripper

Positions:

Ripper lift ..... Raise, hold, and lower



## DOZER EQUIPMENT

Blade capacities are based on the SAE recommended practice J1265.

Use of high tensile strength steel in moldboard for strengthened blade construction.

	Overall Length With Dozer mm ft.in	Blade Capacity m <sup>3</sup> yd <sup>3</sup>	Blade Width x Height mm ft.in	Max. Lift Above Ground mm ft.in	Max. Drop Below Ground mm ft.in	Max. Tilt Adjustment mm ft.in
<b>D61EX-23</b>	5480	3.4	3250 x 1195	1025	580	435
Power Angle Tilt Dozer	<b>18'0"</b>	<b>4.5</b>	<b>10'8" x 3'11"</b>	<b>3'4"</b>	<b>1'11"</b>	<b>17"</b>
<b>D61PX-23</b>	5480	3.8	3860 x 1155	1025	580	515
Power Angle Tilt Dozer	<b>18'0"</b>	<b>5.0</b>	<b>12'8" x 3'9"</b>	<b>3'4"</b>	<b>1'11"</b>	<b>20"</b>