

KOMATSU®

D85EX-18 **D85PX-18**

Tier 4 Final Engine
Waste Handler

CRAWLER DOZER

D85
WASTE HANDLER



Photos may include optional equipment.

NET HORSEPOWER

264 HP @ 1900 rpm
197 kW @ 1900 rpm

OPERATING WEIGHT

Straight Tilt Dozer
D85PX-18: 70,702 lb 32070 kg
Semi-U Tilt Dozer
D85EX-18: 69,922 lb 31716 kg

BLADE CAPACITY

Straight Tilt Dozer
D85PX-18: 15.4 yd³ 11.7 m³
Semi-U Tilt Dozer
D85EX-18: 18.4 yd³ 14.1 m³

SPECIFICATIONS



ENGINE

Model.....Komatsu SAA6D125E-7*
 Type..... 4-cycle, water-cooled, direct injection
 Aspiration.....Variable geometry turbocharged, air-to-air aftercooled
 Number of cylinders..... 6
 Bore x stroke..... 125 mm x 150 mm **4.49" x 5.69"**
 Piston displacement..... 11.04 ltr **674 in³**
 Governor.....All-speed and mid-range, electronic
 Horsepower
 SAE J1995.....Gross 199 kW **267 HP**
 ISO 9249 / SAE J1349.....Net 197 kW **264 HP**
 Rated rpm..... 1900 rpm
 Fan drive type.....Hydraulic
 Lubrication system
 Method..... Gear pump, force lubrication
 Filter..... Full-flow
 **EPA Tier 4 Final emissions certified



TORQFLOW TRANSMISSION

Komatsu TORQFLOW transmission consists of a water-cooled, 3-element, 1-stage, 1-phase and a planetary gear, multiple-disc clutch transmission which is electronically controlled, hydraulically actuated and force-lubricated for optimum heat dissipation. Shift lock lever and neutral safety switch.

Travel speed	Forward	Reverse
1st	3.3 km/h 2.1 mph	4.4 km/h 2.7 mph
2nd	6.1 km/h 3.8 mph	8.0 km/h 5.0 mph
3rd L	7.8 km/h 4.8 mph	9.2 km/h 5.7 mph
3rd	10.1 km/h 6.3 mph	13.0 km/h 8.1 mph

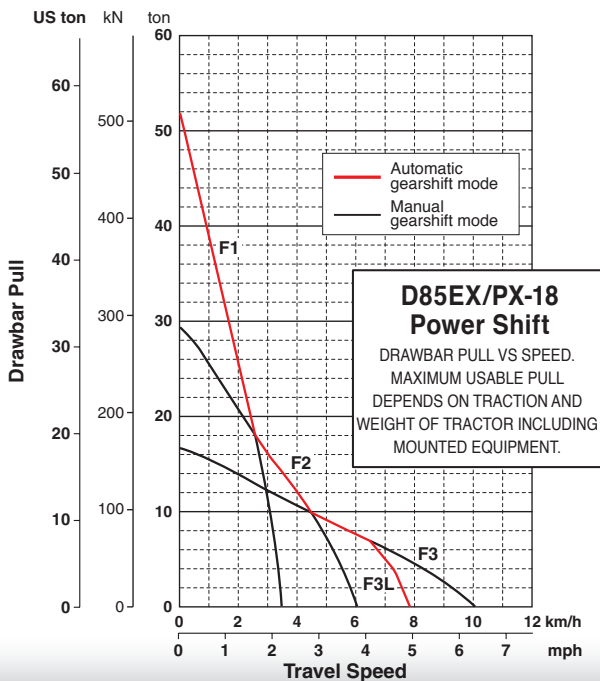

STEERING SYSTEM

Palm Command Control System (PCCS) lever controls for all directional movements. Pushing the PCCS lever forward results in forward machine travel, while pulling it rearward reverses the machine. Simply tilt the PCCS lever to left to make a left turn. Tilt it to the right for a right turn.

Hydrostatic Steering System (HSS) is powered by steering planetary units and a hydraulic pump and motor. Counter-rotation turns are also available. Wet, multiple-disc, pedal-controlled service brakes are spring-actuated and hydraulically released. Gear shift lock lever also applies parking brake.

Minimum turning radius
 D85EX-18..... 2.0 m **6'6"**
 D85PX-18..... 2.2 m **7'3"**



UNDERCARRIAGE

Suspension..... Oscillating equalizer bar and pivot shaft
 Track roller frame..... Monocoque, large section, durable construction

Rollers and idlers..... Lubricated

Track shoes

Lubricated tracks. Unique dust seals for preventing entry of foreign abrasives into pin-to-bushing clearance for extended service life. Track tension is easily adjusted with grease gun.

	D85EX-18	D85PX-18
Number of track rollers (each side)	7	8
Type of shoes (standard)	Single grouser	Single grouser
Number of shoes (each side)	41	45
Grouser height	mm in 72 2.8"	72 2.8"
Shoe width (standard)	mm in 660 26"	910 36"
Ground contact area	cm ² 40260	63340
	in² 6,240	9,820
Ground pressure (tractor)	kPa 59.5	39.8
	kgf/cm ² 0.61	0.40
	psi 8.62	5.77
Track gauge	mm ft.in 2000 6'7"	2250 7'5"
Length of track on ground	mm ft.in 3050 10'0"	3480 11'5"

D85EX/PX-18 WASTE HANDLER



FINAL DRIVES

Double-reduction final drive of spur and planetary gear sets to increase tractive effort and reduce gear tooth stresses for long final drive life. Segmented sprocket teeth are bolt-on for easy replacement. Triple labyrinth protects seals and improves durability.



SERVICE REFILL CAPACITIES

Fuel tank	470 ltr	124.1 U.S. gal
DEF tank	23.5 ltr	6.2 U.S. gal
Coolant	65 ltr	17.2 U.S. gal
Engine.....	38 ltr	10.0 U.S. gal
Damper case	1.6 ltr	0.42 U.S. gal
Torque converter, transmission, bevel gear, and steering system	60 ltr	15.8 U.S. gal
Final drive (each side)		
D85EX-18	26 ltr	6.9 U.S. gal
D85PX-18	36 ltr	9.5 U.S. gal



HYDRAULIC SYSTEM

Closed-center load sensing system (CLSS) designed for precise and responsive control, and for efficient simultaneous operation.

Hydraulic control units:

All spool valves externally mounted beside the hydraulic tank.
Piston type hydraulic pump with capacity (discharge flow) of 331 ltr/min **87.4 U.S. gal/min** at rated engine rpm.

Relief valve setting 22.6 MPa 230 kg/cm² **3,270 psi**

Control valves:

Spool control valves for semi-u tilt or straight tilt dozer

- Positions: Blade lift Raise, hold, lower, and float
- Blade tilt Right, hold, and left
- Rear attachment.....Raise, hold, and lower

	Number of cylinders		Bore
	Straight Tilt Dozer	Semi-U Tilt Dozer	
Blade lift	2		100 mm 4.0"
Blade tilt	1		150 mm 5.9"
Blade angle	-		150 mm 5.9"
Ripper lift	2		130 mm 5.1"
Pitch angle	52° - 58°		-

Hydraulic oil capacity (refill):..... 69 ltr **18.2 U.S. gal**

Ripper equipment (additional volume):

 Multi-shank ripper 11 ltr **2.9 U.S. gal**



DOZER EQUIPMENT

Blade capacities are based on the SAE recommended practice J1265.

Use of high tensile strength steel in moldboard for strengthened blade construction.

	Overall Length With Dozer mm ft.in	Blade Capacity m ³ yd ³	Blade Width x Height mm ft.in	Max. Lift Above Ground mm ft.in	Max. Drop Below Ground mm ft.in	Max. Tilt Adjustment mm ft.in	Weight Dozer equipment kg lb	Ground Pressure* kPa kg/cm ² psi
D85EX-18 Strengthened Semi-U Tilt Dozer	5820 19' 1"	14.1 18.4	3635 x 2180 11' 11" x 7' 2"	1175 3' 10"	530 1' 9"	735 2' 5"	4143 9130	77.3 / 0.79 / 11.2
D85PX-18 Straight Tilt Dozer	6025 19' 9"	11.7 15.4	4355 x 1828 14' 4" x 6'	1230 4' 0"	560 1' 10"	500 1' 8"	3503 7720	49.7 / 0.51 / 7.2

*Ground pressure shows tractor, ROPS cab, full fluids, operator, standard waste handler equipment and applicable blade (EX or PX).

SPECIFICATIONS



DIMENSIONS

	D85EX-18 Semi-U Dozer with counterweight		D85PX-18 Straight Tilt Dozer with counterweight	
A	5924 mm	19'5"	5924 mm	19'5"
B	2000 mm	6'7"	2250 mm	7'5"
C	3322 mm	10'11"	3322 mm	10'11"
C1	3668 mm	12'0"	3668 mm	12'0"
D	3290 mm	10'10"	3290 mm	10'10"
E	3050 mm	10'0"	3480 mm	11'5"
F	395 mm	1'4"	395 mm	1'4"
G	660 mm	2'2"	910 mm	3'0"
H	72 mm	2.8"	72 mm	2.8"

Ground clearance 450 mm **1'6"**

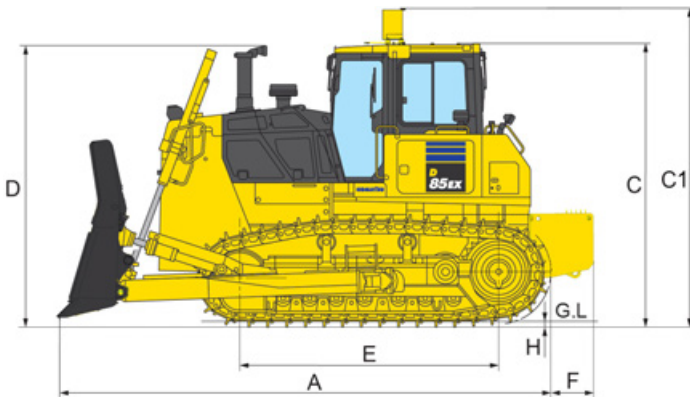
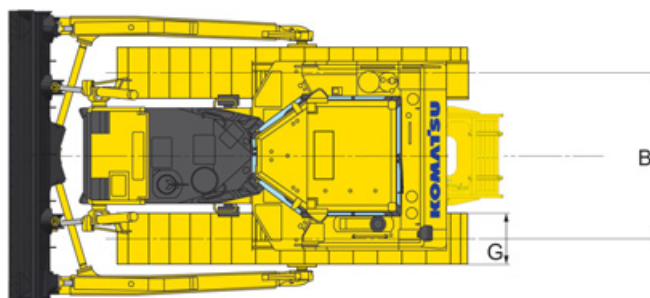

Dimension with straight tilt dozer (D85PX-18) single grouser shoe.



OPERATING WEIGHT

Tractor weight:

Including ROPS cab, rated capacity of lubricant, hydraulic control unit, coolant, full fuel tank, operator, and standard equipment.

D85EX-18 24390 kg **53,770 lb**
 D85PX-18 25700 kg **56,660 lb**

Operating weight:

Including SEMI-U (EX) or straight tilt dozer (PX), landfill counterweight, rear striker bars, standard waste handler equipment, ROPS cab, rated capacity of lubricant, hydraulic control unit, coolant, and full fuel tank.

D85EX-18 31716 kg **69,922 lb**
 D85PX-18 32070 kg **70,702 lb**

D85EX/PX-18 WASTE HANDLER