



STANDARD EQUIPMENT

- Alternator 75 ampere/24V
- Backup alarm
- Batteries 170 Ah/2 x 12V
- Blower fan
- Decelerator pedal
- Dry-type air cleaner with dust evacuator and dust indicator
- Final drive case wear guard
- Hinged front mask
- Hinged underguard with front pull hook
- Hydraulic track adjusters
- Hydrostatic Steering System (HSS)
- Lighting system (including four front and two rear lights)
- Lockup torque converter
- Muffler with rain cap
- Palm lever steering control
- Radiator reserve tank
- ROPS brackets
- Segmented sprockets
- Seven-roller track frames
- Shoes, 610 mm 24" extreme service, single-grouser
- Starting motors 11 kW/24 V
- Suspension seat
- TORQFLOW transmission
- Track roller guards
- Warning horn



OPTIONAL EQUIPMENT

- Air conditioner with heater and defroster
- Alternator 90 ampere/24 V
- Batteries 200 Ah/2 x 12V
- Counterweight
- Cushion dozer
- Cushion push block
- Fire extinguisher
- Hitch
- Hydraulics for ripper
- Light for ripper point
- Mirror, rearview
- Panel cover
- Perforated engine side covers
- Perforated single door radiator mask
- Pusher plate
- Radio, stereo
- Seat
 - Air suspension seat
 - Suspension seat
 - Fabric seat
 - Fabric seat, high backrest
- Seat belt
- Shoes:
 - 710 mm 28"
 - 760 mm 30"
- Spill guard for Semi-U dozer
- Spill guard for Full-U dozer
- Sun visor
- Track shoe slip control system
- Vandalism protection kit

ROPS:*

Weight 605 kg 1,330 lb
 Dimensions
 Width 1980 mm 6'6"
 Height from compartment floor 1835 mm 6'0"

*Meets ISO 3471 and SAE J/ISO 3471 ROPS standards.

Steel cab:*

Weight 455 kg 1,000 lb
 Dimensions:
 Length 1790 mm 5'10"
 Width 1455 mm 4'9"
 Height from compartment floor to ceiling 1530 mm 5'0"

*Meets ISO 3449 FOPS standard.

Multi-shank ripper:

Hydraulically controlled parallelogram ripper with three shanks. Ripping angle infinitely adjustable.

Weight (including hydraulic control unit) 4462 kg 9,840 lb
 Beam length 2495 mm 8'2"
 Maximum lift above ground . . . 955 mm 3'2"
 Maximum digging depth 900 mm 2'11"

Variable giant ripper:

Variable, parallelogram single-shank ripper ideal for ripping up tough material. Ripping angle is infinitely adjustable. Ripping depth is adjustable in three stages by a hydraulically controlled pin puller.

Weight (including hydraulic control unit) 3600 kg 7,940 lb
 Beam length 1252 mm 4'1"
 Maximum lift above ground . . . 870 mm 2'10"
 Maximum digging depth 1300 mm 4'3"

www.Komatsu.com

Printed in Japan 200712 IP.AD (10)



CEN00098-01

Materials and specifications are subject to change without notice.
KOMATSU is a trademark of Komatsu Ltd. Japan.

KOMATSU®

D275AX-5E0

HORSEPOWER

Gross: 337 kW 452 HP @ 2000 rpm

Net: 335 kW 449 HP @ 2000 rpm

OPERATING WEIGHT

51,530 kg 113,600 lb

ecot3

D
275AX

CRAWLER DOZER



Photo may include optional equipment.

SPECIFICATIONS

ENGINE

Model Komatsu SAA6D140E-5
 Type 4-cycle, water-cooled, direct injection
 Aspiration Turbocharged, air-to-air aftercooled, cooled EGR
 Number of cylinders 6
 Bore x stroke 140 mm x 165 mm 5.51" x 6.50"
 Piston displacement 15.24 ltr 930 in³
 Governor All-speed, electronic
 Horsepower
 SAE J1995 Gross **337 kW** 452 HP
 ISO 9249 / SAE J1349* Net **335 kW** 449 HP
 Rated rpm 2000 rpm
 Fan drive type Hydraulic
 Lubrication system
 Method Gear pump, force lubrication
 Filter Full-flow
 *Net horsepower at the maximum speed of radiator cooling fan **306 kW** 410 HP

TORQFLOW TRANSMISSION

Komatsu TORQFLOW transmission consists of a water-cooled, 3-element, 1-stage, 1-phase, torque converter with lockup clutch and a planetary gear, multiple-disc clutch transmission which is hydraulically-actuated and force-lubricated for optimum heat dissipation. Gearshift lock lever and neutral safety switch prevent accidental starts.

Gear	Forward		Reverse	
	km/h	mph	km/h	mph
1st	3.6	2.2	4.7	2.9
2nd	6.7	4.2	8.7	5.4
3rd	11.2	7.0	14.9	9.3

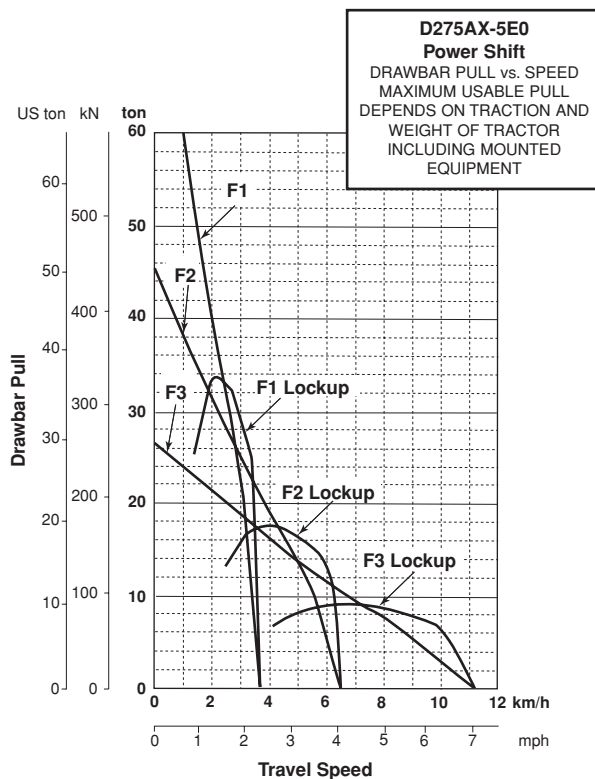

FINAL DRIVES

Double-reduction final drive of spur and planetary gear sets to increase tractive effort and reduce gear tooth stresses for long final drive life. Segmented sprocket rims are bolt-on for easy replacement.

STEERING SYSTEM

PCCS lever controls for all directional movements. Pushing the PCCS lever forward results in forward machine travel, while pulling it rearward reverses the machine. Simply tilt the PCCS lever to left to make a left turn.

Hydrostatic Steering System (HSS) is powered by steering planetary units and an independent hydraulic pump and motor. Counter-rotation turns are also available. Wet, multiple-disc, pedal-controlled service brakes are spring-actuated and hydraulically released. Gear shift lock lever also applies parking brake.

Minimum turning radius **3.9 m** 12'10"

UNDERCARRIAGE

Suspension Oscillating equalizer bar and pivot shaft
 Track roller frame Cylindrical, high-tensile-strength steel construction
 Rollers and idlers Lubricated track rollers

K-Bogie undercarriage
 Lubricated track rollers are resiliently mounted to the roller frame with a series of K-Bogies whose oscillating motion is cushioned by rubber pads.

Extreme service track shoes
 Lubricated tracks. Unique seals prevent entry of foreign abrasive material into pin to bushing clearances to provide extended service life. Track tension is easily adjusted with grease gun.

Number of shoes (each side) 39
 Grouser height:
 Single grouser **88 mm** 3.5"
 Shoe width (standard) **610 mm** 24"
 Ground contact area **42456 cm²** 6,580 in²
 Ground pressure (tractor only) **87.3 kPa** 0.89 kg/cm² 12.7 psi
 Number of track rollers 7
 Number of carrier rollers 2

Extreme service shoes	Additional weight	Ground contact area	Ground pressure
710 mm 28"	570 kg 1,260 lb	49416 cm ² 7,659 in ²	103 kPa 1.05 kg/cm ² 15.0 psi
760 mm 30"	850 kg 1,870 lb	52,896 cm ² 8,199 in ²	97 kPa 0.99 kg/cm ² 14.1 psi

COOLANT AND LUBRICANT CAPACITY (REFILL)

Fuel tank **840 ltr** 222 U.S. gal
 Coolant **100 ltr** 26.4 U.S. gal
 Engine **52.0 ltr** 13.7 U.S. gal
 Torque converter, transmission,
 bevel gear, and steering system **90 ltr** 23.8 U.S. gal
 Final drive (each side) **40 ltr** 10.6 U.S. gal

DIMENSIONS

SIGMADOZER WITH GIANT RIPPER

A	2260 mm	7'5"
B	4440 mm	14'7"
C	3915 mm	12'10"
D	2150 mm	7'1"
E	3480 mm	11'5"
F	8995 mm	29'6"
G	3030 mm	9'11"
H	1300 mm	4'3"
I	870 mm	2'10"
J	3990 mm	13'1"

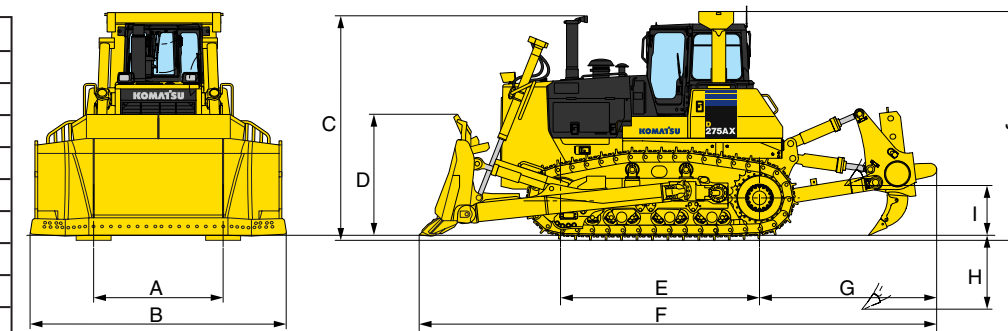

Ground Clearance: 507 mm 1'8"

OPERATING WEIGHT

Tractor weight **37680 kg** 83,070 lb
 Including rated capacity of lubricant, coolant, full fuel tank, operator, and standard equipment.

Operating weight **51,530 kg** 113,600 lb
 Including Strengthened Dual tilt SIGMADOZER, giant ripper, steel cab, ROPS, operator, standard equipment, rated capacity of lubricant, coolant, and full fuel tank.

Ground pressure **119 kPa** 1.21 kg/cm² 17.2 psi

HYDRAULIC SYSTEM

Closed-center Load Sensing System (CLSS) designed for precise and responsive control, and for efficient simultaneous operation.

Hydraulic control units:
 All spool valves externally mounted beside the hydraulic tank.
 Plunger type hydraulic pump with capacity (discharge flow) of **230 ltr/min** 60.8 U.S. gal/min at rated engine rpm.

Relief valve setting **27.5 MPa** 280 kg/cm² 3,980 psi

Control valves:
 Spool control valves for SIGMADOZER, Semi-U tilt dozer and Full-U tilt dozer
 Positions: Blade lift Raise, hold, lower, and float
 Blade tilt Right, hold, and left

Additional control valve required for variable digging angle multi-shank ripper and giant ripper.
 Positions: Ripper lift Raise, hold, and lower
 Ripper tilt Increase, hold, and decrease

DOZER EQUIPMENT

Blade capacities are based on the SAE recommended practice J1265.

	Overall length with dozer	Blade capacity	Blade length x height	Maximum lift above ground	Maximum drop below ground	Maximum tilt adjustment	Weight*		Ground pressure**
							Dozer equipment	Hydraulic oil	
Strengthened Dual tilt SIGMADOZER	6665 mm 21'10"	14.6 m ³ 19.1 yd ³	4440 mm x 2150 mm 14'7" x 7'1"	1390 mm 4'7"	745 mm 2'5"	1070 mm 3'6"	9110 kg 20,080 lb	35 kg 77 lb	119 kPa 1.21 kg/cm ² 17.2 psi
Strengthened SIGMADOZER	6665 mm 21'10"	14.6 m ³ 19.1 yd ³	4440 mm x 2150 mm 14'7" x 7'1"	1390 mm 4'7"	745 mm 2'5"	1000 mm 3'3"	9030 kg 19,910 lb	29 kg 64 lb	119 kPa 1.21 kg/cm ² 17.2 psi
Semi-U tilt dozer	6930 mm 22'9"	13.7 m ³ 17.9 yd ³	4300 mm x 1960 mm 14'1" x 6'5"	1450 mm 4'9"	640 mm 2'1"	1000 mm 3'3"	7480 kg 16,490 lb	29 kg 64 lb	115 kPa 1.17 kg/cm ² 16.6 psi
Full-U tilt dozer	7265 mm 23'10"	16.6 m ³ 21.7 yd ³	4615 mm x 1973 mm 15'2" x 6'6"	1450 mm 4'9"	640 mm 2'1"	1070 mm 3'6"	8405 kg 18,530 lb	29 kg 64 lb	118 kPa 1.20 kg/cm ² 17.1 psi
Dual tilt Semi-U dozer	6930 mm 22'9"	13.7 m ³ 17.9 yd ³	4300 mm x 1960 mm 14'1" x 6'5"	1450 mm 4'9"	640 mm 2'1"	1140 mm 3'9"	7560 kg 16,670 lb	35 kg 77 lb	116 kPa 1.18 kg/cm ² 16.8 psi
Dual tilt Full-U dozer	7265 mm 23'10"	16.6 m ³ 21.7 yd ³	4615 mm x 1973 mm 15'2" x 6'6"	1450 mm 4'9"	640 mm 2'1"	1220 mm 4'0"	8485 kg 18,710 lb	35 kg 77 lb	118 kPa 1.20 kg/cm ² 17.1 psi

* Additional weight to obtain the weight of strengthened type dozer equipment.
 For strengthened Semi-U dozer: + 1050 kg For strengthened Full-U tilt dozer: + 1200 kg
 ** When calculating the operating weight of dual tilt dozer, add the 50 kg weight of additional hydraulic system to the tractor weight.
 ** Ground pressure shows tractor, cab, ROPS, operator, giant ripper standard equipment and applicable blade.