

WASTE HANDLER SPECIFICATIONS



ENGINE

Model.....Komatsu SAA6D114E-5*
 Type..... 4-cycle, water-cooled, direct injection
 Aspiration..... Komatsu variable geometry turbocharged, air-to-air aftercooled
 Number of cylinders..... 6
 Bore x stroke..... 114 mm x 144.5 mm **4.49" x 5.69"**
 Piston displacement.....8.85 ltr **540 in³**
 Governor.....All-speed and mid-range, electronic
 Horsepower
 SAE J1995.....Gross 155 kW **207 HP**
 ISO 9249 / SAE J1349..... Net 153 kW **205 HP**
 Rated rpm..... 1950 rpm
 Fan drive typeHydraulic
 Lubrication system
 Method..... Gear pump, force lubrication
 Filter..... Full-flow
 *EPA Tier 4 Interim and EU stage 3B emissions certified



TORQFLOW TRANSMISSION

Komatsu TORQFLOW transmission consists of a water-cooled, 3-element, 1-stage, 2-phase, torque converter with lockup clutch, and a planetary gear, multiple-disc clutch transmission which is electronically controlled, hydraulically actuated and force-lubricated for optimum heat dissipation. Shift lock lever and neutral safety switch.

Travel speed	Forward	Reverse
1st	3.6 km/h 2.2 mph	4.4 km/h 2.7 mph
2nd	5.5 km/h 3.4 mph	6.6 km/h 4.1 mph
3rd L	7.2 km/h 4.5 mph	8.6 km/h 5.3 mph
3rd	11.2 km/h 7.0 mph	13.4 km/h 8.3 mph

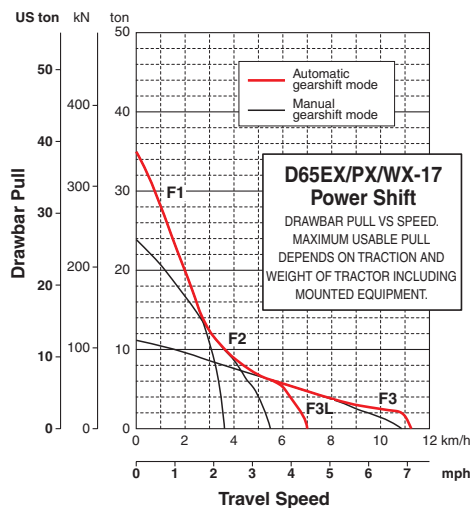

STEERING SYSTEM

Palm Command Control System (PCCS) lever controls for all directional movements. Pushing the PCCS lever forward results in forward machine travel, while pulling it rearward reverses the machine. Simply tilt the PCCS lever to left to make a left turn. Tilt it to the right for a right turn.

Hydrostatic Steering System (HSS) is powered by steering planetary units and a hydraulic pump and motor. Counter-rotation turns are also available. Wet, multiple-disc, pedal-controlled service brakes are spring-actuated and hydraulically released. Gear shift lock lever also applies parking brake.

Minimum turning radius	
D65EX-17	1.9 m 6'3"
D65EX-17 with PAT	2.0 m 6'7"
D65PX-17	2.2 m 7'3"
D65WX-17	2.1 m 6'11"



UNDERCARRIAGE

Suspension..... Oscillating equalizer bar and pivot shaft
 Track roller frameMonocoque, large section, durable construction

Rollers and idlers Lubricated

Track shoes

Parallel Link Undercarriage System (PLUS) with lubricated rotating bushings for extended system wear life and lower maintenance costs. Track tension is easily adjusted with grease gun.

Tractor for outside mounted blade (Straight Tilt, SIGMADOZER)*

	D65EX-17	D65PX-17	D65WX-17
Number of track rollers (each side)	7	8	7
Type of shoes (standard)	Single grouser	Single grouser	Single grouser
Number of shoes (each side)	42	45	42
Grouser height	mm in 65 2.6"	65 2.6"	65 2.6"
Shoe width (standard)	mm in 610 24"	915 36"	760 30"
Ground contact area	cm ² 36234	59935	45145
	in ² 5,616	9,290	6,997
Ground pressure (tractor)	kPa 51	32	41
	kgf/cm ² 0.52	0.33	0.42
	psi 7.44	4.69	6.01
Track gauge	mm ft.in 1880 6'2"	2050 6'9"	2050 6'9"
Length of track on ground	mm ft.in 2970 9'9"	3275 10'9"	2970 9'9"

Tractor for inside mounted blade (PAT)*

	D65EX-17	D65PX-17	D65WX-17
Number of track rollers (each side)	7	8	7
Type of shoes (standard)	Single grouser	Single grouser	Single grouser
Number of shoes (each side)	42	45	42
Grouser height	mm in 65 2.6"	65 2.6"	65 2.6"
Shoe width (standard)	mm in 560 22"	760 30"	760 30"
Ground contact area	cm ² 33265	49780	45145
	in ² 5,156	7,716	6,997
Ground pressure (tractor)	kPa 52	40	43
	kgf/cm ² 0.53	0.41	0.44
	psi 7.61	5.85	6.23
Track gauge	mm ft.in 2050 6'9"	2230 7'4"	2230 7'4"
Length of track on ground	mm ft.in 2970 9'9"	3275 10'9"	2970 9'9"

*See page 14 for tractor/blade combinations.



FINAL DRIVES

Double-reduction final drive of spur and planetary gear sets to increase tractive effort and reduce gear tooth stresses for long final drive life. Segmented sprocket teeth are bolt-on for easy replacement.



HYDRAULIC SYSTEM

Closed-center load sensing system (CLSS) designed for precise and responsive control, and for efficient simultaneous operation.

Hydraulic control units:

All spool valves externally mounted beside the hydraulic tank. Piston type hydraulic pump with capacity (discharge flow) of 248 ltr/min **65.5 U.S. gal/min** at rated engine rpm.

Relief valve setting 27.9 MPa 285 kg/cm² **4,050 psi**

Control valves:

Spool control valves for SIGMADOZER or straight tilt dozer

- Positions: Blade lift Raise, hold, lower, and float
- Blade tilt Right, hold, and left
- Rear attachment..... Raise, hold, and lower



SERVICE REFILL CAPACITIES

Fuel tank	415 ltr	109.6 U.S. gal
Coolant	54 ltr	14.3 U.S. gal
Engine.....	25 ltr	6.6 U.S. gal
Torque converter, transmission, bevel gear, and steering system	48 ltr	12.7 U.S. gal
Final drive (each side)		
D65EX-17	16.5 ltr	4.4 U.S. gal
D65EX-17 with PAT	16.5 ltr	4.4 U.S. gal
D65PX-17	22 ltr	5.8 U.S. gal
D65WX-17	22 ltr	5.8 U.S. gal

Spool control valves for Power Angle Tilt dozer

- Positions: Blade lift Raise, hold, lower, and float
- Blade tilt Right, hold, and left
- Blade angle Right, hold, and left
- Rear attachment..... Raise, hold, and lower

Hydraulic cylinders..... Double-acting, piston

	Number of cylinders	Bore	
		SIGMADOZER Straight Tilt Dozer	Power Angle Power Tilt Dozer
Blade lift	2	85 mm 3.3"	90 mm 3.5"
Blade tilt	1	125 mm 4.9"	130 mm 5.1"
Blade angle	2	N/A	110 mm 4.3"
Ripper lift	1	125 mm 4.9"	125 mm 4.9"
Pitch angle	1	39° - 53°	52° - 58°

Hydraulic oil capacity (refill):..... 55 ltr **14.5 U.S. gal**

Ripper equipment (additional volume):

Multi-shank ripper 7 ltr **1.8 U.S. gal**



DOZER EQUIPMENT

Blade capacities are based on the SAE recommended practice J1265.

Use of high tensile strength steel in moldboard for strengthened blade construction.

Blades With Trash Racks	Overall Length With Dozer mm ft.in	Blade Capacity m ³ yd ³	Blade Width x Height mm ft.in	Max. Lift Above Ground mm ft.in	Max. Drop Below Ground mm ft.in	Max. Tilt Adjustment mm ft.in	Weight Dozer equipment kg lb	Ground Pressure* kPa kg/cm ² psi
D65EX-17 SIGMADOZER	5490 18'0"	12.5 16.3	3410 x 2125 11'2" x 7'0"	1135 3'9"	500 1'8"	870 2'10"	2698 5,940	60/0.61/ 8.68
D65EX-17 Straight Tilt Dozer	5330 17'6"	10.1 13.2	3901 x 1800 12'10" x 5'11"	1105 3'8"	430 1'5"	870 2'10"	2462 5,428	58/0.59/ 8.40
D65EX-17 Power Angle Tilt Dozer	5790 19'0"	11.1 14.5	3870 x 1935 12'8" x 6'4"	1170 3'10"	695 2'3"	500 1'8"	3265 7,196	67/0.68/ 9.67
D65PX-17 Straight Tilt Dozer	5680 18'8"	9.9 12.9	3970 x 1800 13'0" x 5'11"	1130 3'8"	535 1'9"	890 2'11"	2405 5,301	38/0.39/ 5.55
D65PX-17 Power Angle Tilt Dozer	5790 19'0"	11.5 15.1	4010 x 1935 13'2" x 6'4"	1170 3'10"	695 2'3"	520 1'8"	3295 7,262	50/0.51/ 7.25
D65WX-17 SIGMADOZER	5500 18'1"	13.1 17.2	3580 x 2125 11'9" x 7'0"	1135 3'9"	500 1'8"	770 2'6"	2805 6,182	49/0.50/ 7.11
D65WX-17 Power Angle Tilt Dozer	5790 19'0"	11.5 15.1	4010 x 1935 13'2" x 6'4"	1170 3'10"	695 2'3"	520 1'8"	3295 7,262	54/0.55/ 7.82

*Ground pressure shows tractor, ROPS cab, operator, standard equipment and applicable blade (EX, WX, PAT with counterweight).



DIMENSIONS — OUTSIDE MOUNTED DOZER BLADE

	D65EX-17 SIGMADOZER	D65PX-17 Straight Tilt Dozer	D65WX-17 SIGMADOZER
A	5490 mm 18'0"	5680 mm 18'8"	5500 mm 18'1"
B	1880 mm 6'2"	2050 mm 6'9"	2050 mm 6'9"
C	3370 mm 11'1"*	3370 mm 11'1"*	3370 mm 11'1"*
C1	4267 mm 14'0"	4267 mm 14'0"	4267 mm 14'0"
D	3085 mm 10'1"	3085 mm 10'1"	3085 mm 10'1"
E	2970 mm 9'9"	3275 mm 10'9"	2970 mm 9'9"
F	560 mm 22"	915 mm 36"	760 mm 30"
G	65 mm 2.6"	65 mm 2.6"	65 mm 2.6"

*3338 mm **10'11"** is overall height if Komatsu sweeps are installed.

C1: Roof mounted AC can be relocated for shipping.

Ground clearance 415 mm **1'4"**

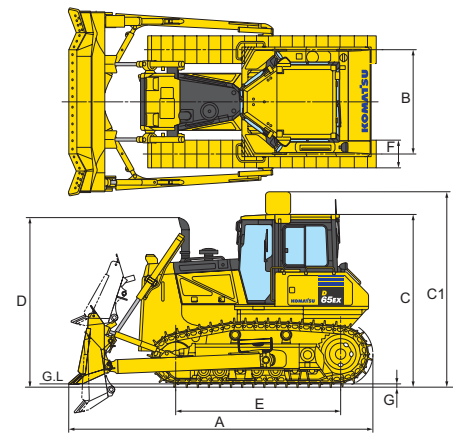
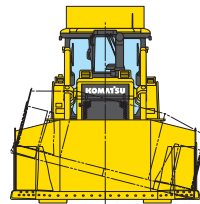

Shown with SIGMADOZER (D65EX-17) single grouser shoe.
Blade shown without Trash Rack.



DIMENSIONS — PAT DOZER BLADE

	D65EX-17 PAT Dozer	D65PX-17 PAT Dozer	D65WX-17 PAT Dozer
A	5790 mm 19'0"	5790 mm 19'0"	5790 mm 19'0"
B	2050 mm 6'9"	2230 mm 7'4"	2230 mm 7'4"
C	3370 mm 11'1"*	3370 mm 11'1"*	3370 mm 11'1"*
C1	4267 mm 14'0"	4267 mm 14'0"	4267 mm 14'0"
D	3085 mm 10'1"	3085 mm 10'1"	3085 mm 10'1"
E	2970 mm 9'9"	3275 mm 10'9"	2970 mm 9'9"
F	560 mm 22"	760 mm 30"	760 mm 30"
G	65 mm 2.6"	65 mm 2.6"	65 mm 2.6"
H	3545 mm 11'8"	3670 mm 12'0"	3670 mm 12'0"

*3338 mm **10'11"** is overall height if Komatsu sweeps are installed.

C1: Roof mounted AC can be relocated for shipping.

Ground clearance 415 mm **1'4"**

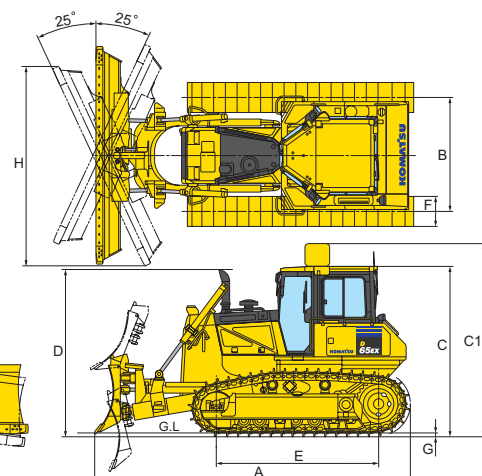
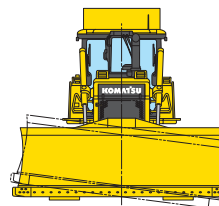

Shown with Power Angle Tilt dozer (D65EX-17) single grouser shoe.
Blade shown without Trash Rack.



OPERATING WEIGHT

Tractor weight:

Including ROPS cab, rated capacity of lubricant, hydraulic control unit, coolant, full fuel tank, operator, and standard equipment.

D65EX-17	18961 kg 41,802 lb
D65PX-17	19781 kg 43,610 lb
D65WX-17	19081 kg 42,066 lb

for PAT dozer (EX, WX with rear counterweight)

D65EX-17	19380 kg 42,725 lb
D65PX-17	20470 kg 45,128 lb
D65WX-17	19770 kg 43,585 lb

Operating weight:

Including SIGMADOZER (EX/WX) or straight tilt dozer (PX) or Power Angle Tilt dozer, ROPS cab, operator, standard equipment, rated capacity of lubricant, hydraulic control unit, coolant, and full fuel tank.

D65EX-17	22165 kg 48,865 lb
D65PX-17	23255 kg 51,268 lb
D65WX-17	22555 kg 49,725 lb

for PAT dozer (EX, WX with rear counterweight)

D65EX-17	24483 kg 53,975 lb
D65PX-17	25573 kg 56,379 lb
D65WX-17	24873 kg 54,835 lb