

SD22 推土机(军用型) Bulldozer



SD22系列推土机性能参数 Specifications

发动机ENGINE

型式TYPE 康明斯NT855-C280 (S10)Cummins
 直列、水冷、四冲程、顶阀直接喷射、涡轮增压柴油机
 in-line, water cooled 4-cycle, overhead valve direct injection, turbocharged diesel
 额定转速Rated revolution 1800rpm
 额定功率Rated horsepower 162KW
 缸数-缸径×行程Cylinder number-bore×stroke 6-139.7mm×152.4
 活塞排量piston displacement 14010ml
 最小耗油量Min fuel consumption 205g/KW.h
 油箱容量Tank capacity 450L
 水箱容量water capacity 79L
 最大扭矩Max torque 1030NM/1250rpm

速度档Gear	I档1st	II档2nd	III档3rd
前进Forward(km)	0-3.6	0-6.5	0-11.2
后退Reverse(km)	0-4.3	0-7.7	0-13.2

传动系统特点POWER TRANSMITTING SYSTEM

液力变矩器Torque Converter 三元件一级一相
 3-element 1 stage 1 phase
 变速箱Transmission 行星齿轮、多片离合器、液
 压结合强制润滑式
 Planetary gear, multi-disc clutch, hydraulically connected, forced lubrication
 中央传动Main Drive 螺旋锥齿轮、一级减速、飞溅润滑。
 Spiral bevel gear, splash lubrication, single-stage speed reduction
 转向离合器Steering Clutch 湿式、多片弹簧压紧、液
 压分离、液压操作
 Wet, multi-disc, spring loaded, hydraulically separated, hydraulic control
 转向制动器Steering Brake 湿式、浮式、直接离合、
 液压助力、联动操作
 Wet, floating, direct on-off hydraulic inter-linking operation
 最终传动Final drive 二级直齿轮减速、飞溅润滑
 2-stage speed reduction of spur gear, splash lubrication

行走系统UNDERCARRIAGE SYSTEM

型式Type 八字梁摆动式，平衡梁悬挂结构
 Swing type of sprayed beam, suspended structure of equalizer bar
 托轮数Carrier rollers 2个/每边(each side)
 支重轮数Track rollers 6个/每边(单边4个双边2个)(E型7个/每边)
 6/each side(single flange 4, double flange 2)(E-7/each side)
 履带型式Track type 装配式单履齿(每边38块) Assembled
 single-tooth shoes(38/each side)
 履带板宽度Width of track shoes 560mm
 链轨节距Pitch 216mm

动力输出轴POWER TAKE OFF SHAFT

位置Location 后桥箱后面中间At the middle
 of the back of steering case
 转速Revolution 1800rpm

液压系统HYDRAULIC SYSTEM

最高工作油压Max. pressure 14MPa
 油泵型式Pump type 齿轮油泵gear pump
 流量Discharge 262L/min(发动机转速1800rpm)
 (at revolution of 1800rpm)
 工作油缸内径×数量 120mm×2(双作用式)bore
 of working cylinder×number (double-acting type)

外形尺寸OVERALL DIMENSIONS

(直倾铲)

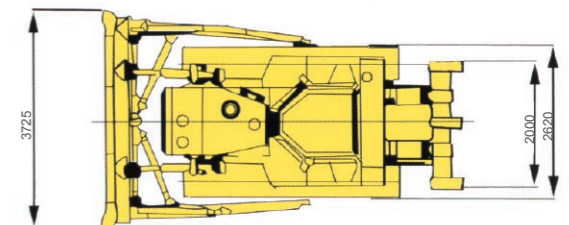
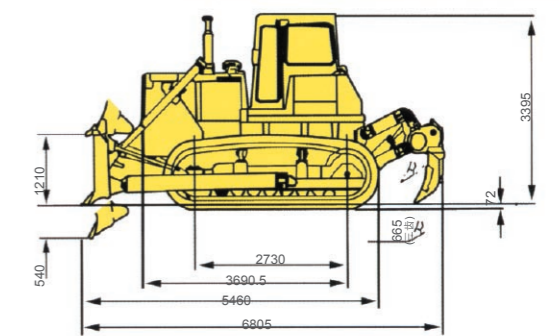

铲型Dozer	直倾铲 straight-tilt	角铲 angle	U型铲 Udozer	环卫铲 R-blade	推煤铲 Coal blade
最小离地间隙Min. ground clearance(mm)	405	405	405	513	405
使用质量Operating weight(kg)	23450	23670	24020	25700	24850
接地比压Ground pressure(MPa)	0.077	0.077	0.078	0.041	0.078
最小转弯半径Min. turning radius(m)	3.3	3.3	3.3	3.8	3.3
爬坡性能Gradeability(°)	30	30	30	30	30
履带中心距Track gauge(mm)	2000	2000	2000	2250	2000
单铲容量Dozing capacity(m ³)	6.4	4.7	7.5	10.2	9
生产率Efficiency(m ³ /h)(理论值Theoretical value远距为40米)	330	245	365	413	450
铲刀宽度Blade width(mm)	3725	4365	3800	4160	4200
铲刀高度Blade height(mm)	1315	1055	1343	1870	1350
最大切削深度Max. drop below ground (mm)	540	535	540	540	540
铲刀最大倾斜Max. tilt adjustment(mm)	>735	>500	>755	>755	>755
质量Weight(kg)	3630	3850	4196	3067	3464



绞车



单齿松土器



三齿松土器