

ST35, ST45

The Wacker Neuson Compact Track Loaders (CTL) deliver high operating capacity and maneuverability across rugged terrain. The ST35 radial lift delivers 3,500 lbs of ROC at 50% of tip load and a lift height up to 125". The ST45 vertical lift delivers 4,500 lbs of ROC at 50% and a lift height up to 134". Both machines are equipped with a 74.3 hp turbo-charged Perkins Tier 4 Final engine. Available in both H-pattern and ISO joystick hydraulic pilot controls, the machines can fit the preferences of any user. The ergonomically designed controls and pressurized cab deliver comfort and visibility, reducing operator fatigue and increasing safety.

	ST35	ST45
Horsepower	74.3 hp	74.3 hp
Operating weight	9,827 lbs	10,245 lbs
ROC @ 50%	3,500 lbs	4,500 lbs
Bucket hinge height	125.9"	135.4"
Std. hydraulic flow	22.5 gpm	22.5 gpm



Versatility
Wide range of attachments for any and all jobs.



Vertical Lift
Class leading 134" lift height.

- Optional features:**
- Fully enclosed pressurized cab with HVAC system
 - Engine Block Heater
 - Ride Control
 - AM/FM Radio
 - One-way Hydraulic Self-leveling
 - Adjustable Auxiliary High Flow
 - Additional Counterweights
 - Rotating Beacon
 - Additional options available

Technical data

		SW24	SW28	ST35	ST45
UNIT					
Bucket dump angle w/ bucket at max. height	Degrees	45°	38°	45°	38°
Engine power	hp (kW)	74.3 (55.4)	74.3 (55.4)	74.3 (55.4)	74.3 (55.4)
Engine make/model		Perkins 854F-E34T Tier 4 Final	Perkins 854F-E34T Tier 4 Final	Perkins 854F-E34T Tier 4 Final	Perkins 854F-E34T Tier 4 Final
Operating weight	lb (kg)	7,865 (3,568)	8,283 (3,757)	9,827 (4,457)	10,245 (4,647)
ROC 50%	lb (kg)	2,350 (1,068)	2,800 (1,273)	3,500 (1,591)	4,500 (2,045)
ROC 35%	lb (kg)	-	-	2,450 (1,114)	3,150 (1,432)
Fuel capacity	gal (l)	24.3 (92.0)	24.3 (92.0)	24.3 (92.0)	24.3 (92.0)
Aux. flow (standard)	gal (l)/min	22.5 (85)	22.5 (85)	22.5 (85)	22.5 (85)
Aux. flow (high flow)	gal (l)/min	35.9 (136)	35.9 (136)	35.9 (136)	35.9 (136)
Aux. relief pressure	psi (bar)	3,338 (230)	3,338 (230)	3,338 (230)	3,338 (230)
Travel speed (low)	mph (kph)	6.8 (11)	6.8 (11)	4.3 (6.9)	4.3 (6.9)
Travel speed (high)	mph (kph)	11.2 (18)	11.2 (18)	8.7 (14)	8.7 (14)
Traction force	lb (kg)	12,300 (5,579)	12,300 (5,579)	12,300 (5,579)	12,300 (5,579)

		SW24	SW28	ST35	ST45
UNIT					
A Height to top of ROPS	ft in (mm)	81.9 (2,080)	81.9 (2,080)	81.9 (2,080)	81.9 (2,080)
B Overall length with bucket	ft in (mm)	144.2 (3,662)	143.9 (3,655)	144.2 (3,662)	143.9 (3,655)
C Bucket hinge pin lift height	ft in (mm)	125.2 (3,179)	134.6 (3,418)	125.9 (3,199)	135.4 (3,438)
D Bucket dump height at max. height	ft in (mm)	95.2 (2,419)	107.1 (2,721)	95.2 (2,419)	107.1 (2,721)
E Bucket dump angle w/ bucket pin at 124 in	degrees	30.5°	30.5°	30.5°	30.5°
F Ground Clearance	in (mm)	9.4 (240)	9.4 (240)	9.4 (240)	9.4 (240)
G Angle of Departure	degrees	25°	25°	30°	30°
H Overall Width	in (mm)	72 (1,830)	72 (1,830)	78 (1,981)	78 (1,981)
I Dump Reach at Max Height	in (mm)	22.6 (574)	35.2 (894)	21.7 (552)	34.3 (872)

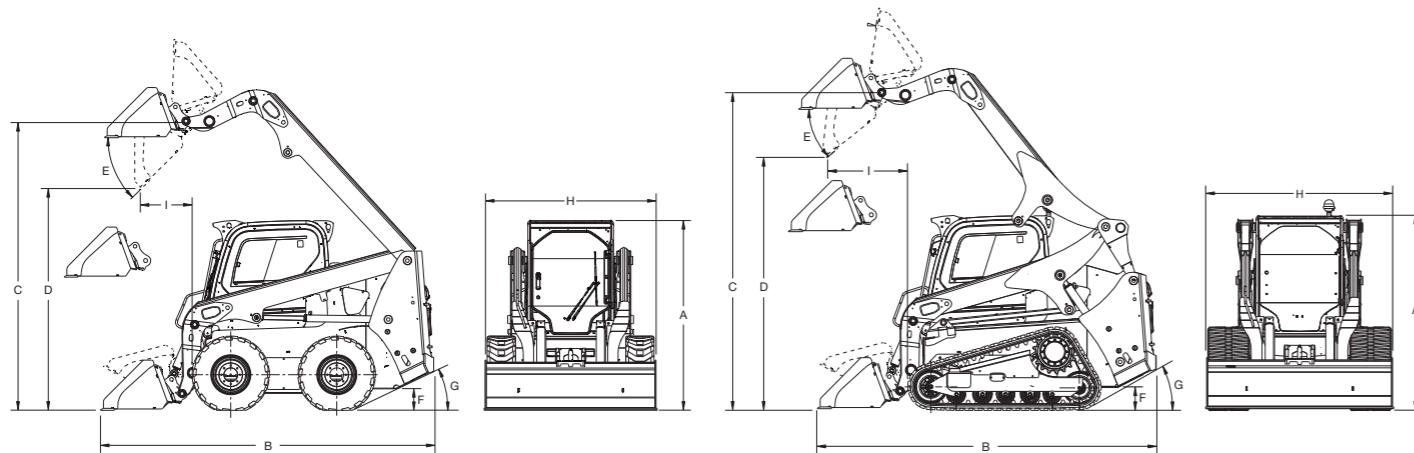

Standard equipment and options

	SW24	SW28	ST35	ST45
Two speed transmission	●	●	●	●
Adjustable full suspension seat	●	●	●	●
Hydraulic pilot controls - ISO or H-pattern available	●	●	●	●
Back up alarm	●	●	●	●
Front and rear working lights	●	●	●	●
Rear and top windows	●	●	●	●
Auxiliary hydraulics with Faster quick coupler pressure relief	●	●	●	●
12 x 16.5 inch standard duty tires	●	●	-	-
17.7 inch wide rubber tracks	-	-	●	●
Mechanical coupler	●	●	●	●

