

	S850	T870
Machine Rating		
Rated operating capacity (ISO 14397-1)	1850 kg	1584 kg
Tipping load	3700 kg	4526 kg
Pump capacity	87.1 l/min	90.1 l/min
Pump capacity (with high flow option)	140 l/min	141.6 l/min
System relief at quick couplers	238–245 bar	238–245 bar
Max. travel speed (low range)	11.4 km/h	10.5 km/h
Max. travel speed (high range)	19.8 km/h	18.3 km/h

Engine		
Make / Model	Kubota / V3800-DI-T-E3	
Fuel / Cooling	Diesel / Liquid	
Maximum power	68.6 kW	74 kW
Torque (SAE J1995)	314.5 Nm (at 1600 RPM)	325 Nm (at 1600 RPM)
Number of cylinders	4	
Displacement	3769 cm ³	

Weights		
Operating weight	4540 kg	5751 kg

Controls		
Vehicle steering	Direction and speed controlled by two joysticks	
Loader hydraulics tilt and lift	Selectable Joystick Control (SJC)	
Front auxiliary (standard)	Electrical switch on right-hand joystick	

Drive System		
Transmission	Infinitely variable tandem hydrostatic piston pumps, driving two fully reversing hydrostatic motors	

Fluid Capacities		
Cooling system capacity with heater	14.4 l	18.5 l
Cooling system capacity w/o heater	-	15.1 l
Engine oil with filter capacity	11.4 l	11.4 l
Fuel tank capacity	124.2 l	134.8 l
Hydraulic reservoir capacity	11.4 l	11.4 l
Hydraulic / hydrostatic system capacity	36 l	36 l

Environmental		
Operator LpA (EU Directive 2006/42/EC) / (uncertainty)	81.7 dB (A) / 2.5 dB (A)	82.4 dB (A) / 2.5 dB (A)
Noise level LWA (EU Directive 2000/14/EC)	102 dB (A)	104 dB (A)
Whole body vibration (ISO 2631-1) / (uncertainty)	0.6 ms ⁻² / 0.3 ms ⁻²	1.5 ms ⁻² / 0.6 ms ⁻²
Hand-arm vibration (ISO 5349-1)	0.71 ms ⁻²	0.49 ms ⁻²

Standard Features

S850	T870
Selectable Joystick Controls (SJC)	Selectable Joystick Controls (SJC)
2nd speed	Roller Suspension™ undercarriage
14 x 17.5 HD tyres, 12 ply	450 mm rubber tracks
	Enclosed cab

Options

S850	T870
High Flow Hydraulics	High Flow Hydraulics
Cab enclosure with heating	Cab enclosure with heating
Cab enclosure with heating and air conditioning	Cab enclosure with heating and air conditioning
Deluxe instrumentation panel	Deluxe instrumentation panel
Power Bob-Tach	Power Bob-Tach
SCPA (Standard Control Power Assist)	2 nd speed
14 x 17.5, 12 ply, Severe Duty tyres	
14 x 17.5, 12 ply, Solid Flex tyres	
14 x 17.5, 12 ply, Severe Duty tyres, Poly-filled	

Attachments

Angle Broom	Mower
Auger	Pallet Forks, Hydraulic
Bale Fork	Pallet Forks, Standard
Brush Saw	Snowblower
Buckets	Sod Layer
Concrete Pump	Soil Conditioners
Dozer Blade	Spreader
Dumping Hopper	Stabilizer, Rear Quick-Tach
Flail Cutter	Stump Grinder
Forestry Cutter	Tree Transplanter
Grader	Vibratory Rollers
Grapple, Industrial	Water Kit
Grapple, Root	Wheel Saw
Hydraulic Breaker	Wood Chipper
Mixing Bucket	

Dimensions

All dimensions in mm.

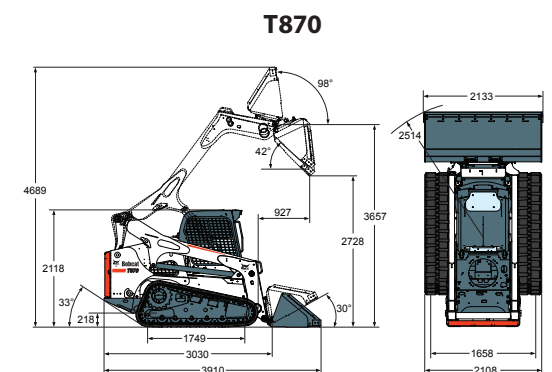
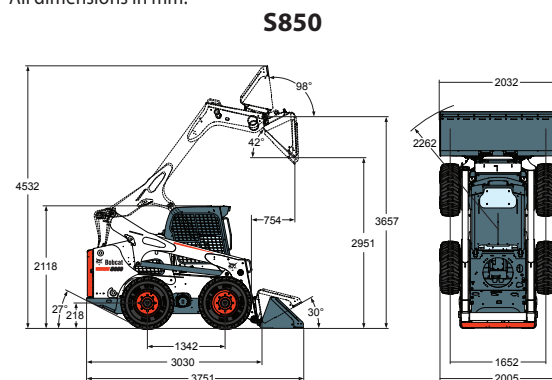

Specifications and design are subject to change without notice. Pictures of Bobcat products may show other than standard equipment.

www.bobcat.eu



Bobcat®

