

312D/312D L Hydraulic Excavator Specifications

Engine

Engine Model	Cat® C4.2 ACERT™
Gross Power	72 kW/98 hp
Net Power	
ISO 9249	67 kW/91 hp
80/1269/EEC	67 kW/91 hp
Bore	102 mm
Stroke	130 mm
Displacement	4.25 liter

- All engine horsepower (hp) are metric including front page.
- Net power advertised is the power available at the flywheel when the engine is equipped with fan, air cleaner, muffler and alternator.
- No engine derating required below 2300 m altitude.
- The 312D/312D L meet EU Stage IIIA Directive 97/68/EC emissions requirements.

Hydraulic System

Main Implement System	
Maximum Flow (2x)	127 l/min
Maximum Pressure	
Implements	305 bar
Travel	350 bar
Swing	230 bar
Pilot System	
Maximum Flow	22 l/min
Maximum Pressure	41 bar
Boom Cylinders	
Bore	110 mm
Stroke	1015 mm
Stick Cylinder	
Bore	120 mm
Stroke	1197 mm
Bucket Cylinder	
Bore	100 mm
Stroke	939 mm

Sound

Operator Sound

- The operator sound pressure level measured according to the procedures specified in ISO 6396:1992 is 72 dB(A), for cab offered by Caterpillar, when properly installed and maintained and tested with the doors and windows closed.

Exterior Sound

- The European Union 2000/14/EC labeled exterior sound power level is 98 dB(A) for the machines certified to that requirement.

Operating Weights

Weights will depend on final machine configuration.

Reach Boom

Stick	Short	Medium	Long	Short	Medium	Long
	2100 mm	2500 mm	3000 mm	2100 mm	2500 mm	3000 mm
	Without Blade			With Blade		
	kg	kg	kg	kg	kg	kg
312D						
500 mm triple grouser shoes	12 860	12 900	12 920	13 650	13 690	13 720
600 mm triple grouser shoes	13 090	13 130	13 150	16 890	13 930	13 950
700 mm triple grouser shoes	13 340	13 380	13 410	14 150	14 190	14 220
770 mm triple grouser shoes	13 480	13 520	13 540	14 290	14 330	14 350
312D L						
500 mm triple grouser shoes	13 410	13 180	13 200	13 930	13 970	14 000
600 mm triple grouser shoes	13 390	13 430	13 450	14 180	14 220	14 250
700 mm triple grouser shoes	13 660	13 700	13 720	14 470	14 510	14 530
770 mm triple grouser shoes	13 800	13 840	13 870	14 610	14 650	14 680

Dimensions with Reach Boom and VA Boom

All dimensions are approximate.

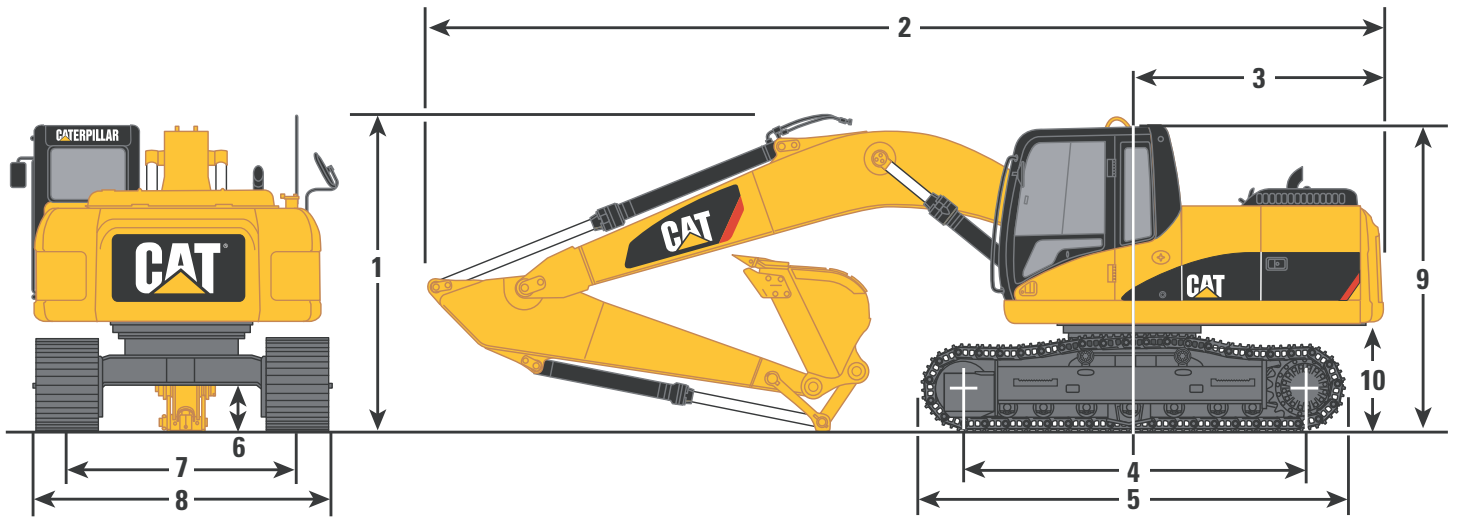

Boom	Reach Boom			VA Boom			
Stick	mm	2100	2500	3000	2100	2500	3000
1 Shipping height	mm	2830	2970	2830	2830	2970	2830
2 Shipping length	mm	7610	7590	7610	7610	7590	7610
3 Tail swing radius	mm	2140	2140	2140	2140	2140	2140
4 Length to centers of idler and sprocket							
312D	mm	2780	2780	2780	2780	2780	2780
312D L	mm	3040	3040	3040	3040	3040	3040
5 Track length							
312D	mm	3490	3490	3490	3490	3490	3490
312D L	mm	3750	3750	3750	3750	3750	3750
6 Ground clearance	mm	430	430	430	430	430	430
7 Track gauge	mm	1990	1990	1990	1990	1990	1990
8 Transport width (500 mm shoes)	mm	500	600	700	500	600	700
312D	mm	2490	2590	2690	2490	2590	2690
312D L	mm	2490	2590	2690	2490	2590	2690
9 Cab height	mm	2760	2760	2760	2760	2760	2760
10 Counterweight clearance	mm	915	915	915	915	915	915

Swing Mechanism

Maximum Swing Torque	31 kNm
Maximum Swing Speed	12.4 rpm

Drive

Maximum Drawbar Pull	114 kN
Maximum Travel Speed	5.5 km/h

Service Refill Capacities

	liter
Fuel Tank	250
Cooling System	18
Engine Oil	20
Swing Drive	3
Final Drive (each)	3
Hydraulic System (including tank)	162
Hydraulic Tank	150

Cab/FOGS

Bolt-on Falling Object Guard System (FOGS) is available as an attachment. Optional Falling Object Guard System is designed to protect the operator from falling objects, and is certified under ISO 3449-1984 specifications.