

SPECIFICATIONS

		M08	Z17 GEN:2	Z25	Z35 GEN:2
ENGINE	Make	Yanmar	Yanmar	Yanmar	Yanmar
	Model	2TE67L-BV4 Tier IV	3TNV74F-SPBV Tier IV	3TNV80F Tier IV	3TNV88F-ESBV Tier IV
	Type	Diesel	Diesel	Diesel	Diesel
	Displacement (L)	30.9 cu.in. (.507)	60.6 cu.in. (0.993)	77.3 cu.in. (1.26)	100.2 cu.in. (1.64)
	Gross Power (kW) @ rpm	10.6 hp (7.9) @ 2,800	15.01 hp (11.2) @ 2400	20.4 hp (15.2) @ 2500	24.5 hp (18.2) @ 2200
	Net Power (kW) @ rpm	10.0 hp (7.5) @ 2,800	14.5 hp (10.8) @ 2400	19.7 hp (14.7) @ 2500	23.9 hp (17.8) @ 2200
	Fuel Tank (L)	2.6 gal. (9.7)	5.3 gal. (20)	8.1 gal. (30.5)	10.8 gal. (41)
	Fuel Consumption (L/hr)	0.28 gal./hr. (1.1)	0.53 gal./hr. (2)	0.95 gal./hr (3.6)	1.03 gal./hr (3.9)
HYDRAULIC SYSTEM	Pumps	2 gear	2 variable, 2 gear	2 variable, 2 gear	2 variable, 2 gear
	Total Flow Rate (L/min)	5.2 gpm (19.6)	15.4 gpm (58.3)	24.5 gpm (92.7)	29.3 gpm (110.8)
	Working Pressure (bar)	2,625 psi (181)	2,987 psi (206)	2,987 psi (206)	3,060 psi (211)
	Swing System Pressure (bar)	1,001 psi (69)	2,103 psi (145)	2,103 psi (145)	2,844 psi (196)
	Oil Cooler	Standard	Standard	Standard	Standard
	Hydraulic Tank (L)	1.5 gal. (5.7)	6.6 gal. (25)	6.6 gal. (25)	10.6 gal. (40)
UNDERCARRIAGE AND SLEWING SYSTEM	Travel Speed - dual (km/hr)	1.1 mph (1.8)	1.3/2.7 mph (2.1/4.3)	1.7/2.8 mph (2.8/4.5)	1.7/2.8 mph (2.7/4.5)
	Gradeability	20°	20°	20°	20°
	Track Type / Width (mm)	Rubber / 7.1" (180)	Rubber / 9.1" (230)	Rubber / 9.8" (250)	Rubber / 11.8" (300)
	No. of Rollers per Side (track/idle)	2/1	3/1	4/1	4/1
	Track Length on Ground (mm)	3' 3.6" (1006)	4' 3.4" (1305)	5' 8.8" (1748)	5' 10" (1778)
	Ground Clearance (mm)	5.1" (130)	6.9" (175)	12.6" (320)	12.6" (320)
	Ground Pressure - Cab/Canopy (kPa)	4.2 psi (28.8)	4.1 psi (28.6)	4.6/4.4 psi (31.7/30.2)	5.0/4.8 psi (34.3/33.1)
	Slew Speed	8.4 rpm	9.5 rpm	10 rpm	9.5 rpm
	Maximum Drawbar Pull (kg)	1,550 lbs (703)	4,181 lbs. (1897)	5,490 lbs. (2490)	7,306 lbs. (3314)
	Maximum Bucket Breakout (kg) with quick coupler	N/A	N/A	4,079 lbs. (1850)	5,643 lbs. (2560)
	Maximum Bucket Breakout (kg) without quick coupler	2,360 lbs. (1071)	3,417 lbs. (1550)	5,203 lbs. (2360)	7,216 lbs. (3273)
	Maximum Arm Digging Force (kg) with quick coupler	N/A	N/A	2,624 lbs. (1190)	4,226 lbs. (1917)
Maximum Arm Digging Force (kg) without quick coupler	1,390 lbs. (631)	1,918 lbs. (870)	2,844 lbs. (1290)	4,586 lbs. (2080)	
DIMENSIONS	Operating Weight with Canopy (kg)	2,348 lbs (1065)	3,836 lbs. (1740)	5,919 lbs. (2685)	7,905 lbs. (3585)
	Operating Weight with Cab (kg)	N/A	N/A	6,217 lbs. (2820)	8,214 lbs. (3725)
	A. Max. Digging Depth (mm)	4' 11.1" (1500)	7' 2.6" (2200)	9' 8" (2950)	10' 8" (3250)
	B. Max. Vertical Wall Digging Depth (mm)	4' 1.6" (1260)	6' 0.8" (1850)	7' 9" (2370)	7' 11" (2410)
	C. Max. Reach at Ground Level (mm)	8' 11.5" (2730)	12' 2.1" (3710)	15' 9" (4800)	17' 3.5" (5270)
	D. Transport Length (mm)	8' 6.4" (2600)	11' 3.8" (3450)	13' 5" (4090)	15' 8" (4770)
	E. Undercarriage Length (mm)	4' 0" (1220)	5' 0" (1525)	6' 8" (2040)	7' 1" (2160)
	F. Max. Digging Height (mm)	9' 0.3 (2750)	12' 1.3" (3690)	14' 8.4" (4480)	16' 9.2" (5110)
	G. Max. Dump Height (mm)	6' 4.8" (1950)	8' 7.5" (2630)	9' 1.4" (2780)	11' 2.3" (3410)
	H. Minimum Front Swing Radius (mm)	3' 10.5" (1180)	5' 0.4" (1535)	7' 1" (2160)	7' 1.4" (2170)
	I. Transport Height (mm)	7' 2.6" / 5' 1.0" (2200 / 1550)	7' 6.6" (2300)	8' 2" (2490)	8' 1" (2470)
	J. Blade Below Ground (mm)	8.3" (210)	8.1" (205)	14" (355)	14.6" (370)
	K. Overall Base Width (mm)	2' 2.8" / 2' 9.1" (680 / 840)	3' 1.4"/4' 2.4" (950/1280)	4' 11.1" (1500)	5' 8.5" (1740)
	L. Track Width (mm)	7.1" (180)	9.1" (230)	9.8" (250)	11.8" (300)
	M. Ground Clearance (mm)	5.1" (130)	6.9" (175)	12.6" (320)	12.6" (320)
	N. Parallel Offset Right (mm)	1' 1" (330)	15.7" (400)	1' 7" (485)	2' 1.2" (640)
	O. Parallel Offset Left (mm)	1' 9.3" (540)	2' 1.2" (640)	2' 3" (705)	1' 11.2" (590)
	P. Rear End Swing Radius (mm)	2' 4.5" (725)	2' 1.2" (640)	2' 5.5" (750)	2' 6.5" (775)
	Q. Boom Swing Angle - Left	45°	42°	47°	43°
	R. Boom Swing Angle - Right	90°	65°	74°	65°
	Max. Dig Depth with 8ft. (2.5 m) Flat Bottom	1' 8" to 2' 9" (840)	5' 0" (1520)	8' 2.4" (2500)	9' 1" (2770)
	DOZER BLADE	Width (mm)	2' 3" (680) to 2' 9" (840)	3' 1" (950) to 4' 2" (1280)	4' 11.1" (1500)
Height (mm)		7.1" (180)	9.3" (235)	11.6" (295)	14.6" (370)

Z45 GEN:2	Z55	Z80 GEN:2	M100
Yanmar	Yanmar	Yanmar	Yanmar
4TNV88C-PBV Tier IV	4TNV86CT Tier IV	4TNV98C-WBV Tier IV	4TNV98CT-VBV Tier IV
Diesel	Diesel	Diesel	Diesel
133.6 cu.in. (2.19)	128 cu.in. (2.09)	202.5 cu.in. (3.32)	202.5 cu.in. (3.32)
39.0 hp (29.1) @ 2400	47.6 hp (35.5) @ 2400	56.9 hp (42.4) @ 2000	72.0 hp (53.7) @ 2100
37.7 hp (28.1) @ 2400	44.9 hp (33.5) @ 2400	55.7 hp (41.5) @ 1900	69.3 hp (51.7) @ 2100
17.4 gal. (66)	17.4 gal. (66)	30.4 gal. (115)	30.4 gal. (115)
1.24 gal./hr (4.7)	1.35 gal./hr (5.1)	1.9 gal./hr (7.2)	2.4 gal./hr (9.1)
2 variable, 2 gear	2 variable, 2 gear	2 variable, 2 gear	2 variable, 2 gear
35.1 gpm (132.8)	36.9 gpm (139.4)	56.7 gpm (214.5)	61.6 gpm (233.2)
3,133 psi (216)	3,553 psi (245)	3,699 psi (255)	3,989 psi (275)
3,133 psi (216)	3,133 psi (216)	3,481 psi (240)	3,481 psi (240)
Standard	Standard	Standard	Standard
10.0 gal. (38)	10.0 gal. (38)	15.9 gal. (60)	15.9 gal. (60)
1.5/2.9 mph (2.4/4.6)	1.4/2.6 mph (2.2/4.2)	1.6/2.8 mph (2.5/4.5)	1.6/2.5 mph (2.7/4.4)
20°	20°	20°	20°
Rubber / 13.8" (350)	Rubber / 15.7" (400)	Rubber / 17.7" (450)	Rubber / 19.1" (485)
4/1	4/1	5/1	5/1
7' 4.4" (2246)	8' 6" (2590)	8' 2.4" (2500)	8' 5" (2565)
13.6" (345)	13.6" (345)	15.4" (390)	1' 5.7" (450)
4.4/4.3 psi (30.6/29.4)	4.4/4.25 psi (30.3/29.3)	5.2 psi (35.8)	5.5 psi (37.9)
10 rpm	10 rpm	9 rpm	9.1 rpm
10,611 lbs. (4813)	12,544 lbs. (5690)	14,500 lbs. (6577)	17,243 lbs. (7821)
6,497 lbs. (2947)	7,464 lbs. (3385)	11,332 lbs. (5140)	12,216 lbs. (5541)
8,206 lbs. (3722)	9,419 lbs. (4272)	14,286 lbs. (6480)	N/A
4,676 lbs. (2121)	5,058 lbs. (2294)	8,356 lbs.(3790)	9,500 lbs. (4309)
5,103 lbs. (2315)	5,485 lbs. (2488)	9,171 lbs. (4160)	N/A
10,417 lbs. (4725)	11,850 lbs. (5375)	N/A	N/A
10,814 lbs. (4905)	12,247 lbs. (5555)	18,136 lbs. (8225)	21,550 lbs. (9775)
11' 7.8" (3550)	12' 9.5" (3900)	14' 4.4" (4380)	14' 10.3" (4530)
7' 9.7" (2380)	8' 4.8" (2560)	12' 10.3" (3920)	13' 1.9" (4010)
18' 10" (5740)	20' 1.7" (6140)	23' 5.1" (7140)	24' 3.3" (7400)
17' 5.4" (5320)	18' 3.7" (5580)	21' 2.3" (6460)	21' 3.5" (6490)
8' 6" (2590)	8' 6" (2590)	9' 5.8" (2890)	10' 0.9" (3070)
18' 8.4" (5700)	19' 10.6" (6060)	23' 9.4" (7250)	25' 4.3" (7730)
12' 0.9" (3680)	13' 3.4" (4050)	15' 2.7" (4640)	16' 9.6" (5120)
7' 9.7" (2380)	6' 11.1" (2110)	8' 11.1" (2720)	9' 1.8" (2790)
8' 4" (2540)	8' 4" (2540)	8' 9.9" (2690)	9' 2.6" (2810)
1' 9.3" (540)	1' 10.4" (570) / 1' 9.3" (540) ¹	1' 6.9" (480)	1' 6.1" (460)
6' 4.4" (1940)	6' 6.3" (1990)	7' 5.4" (2270)	7' 7.3" (2320)
13.8" (350)	15.7" (400)	1' 5.7" (450)	1' 7.1" (485)
13.6" (345)	13.6" (345)	15.4" (390)	1' 5.7" (450)
2' 6.3" (770)	2' 6.3" (770)	2' 0.4" (620)	2' 1" (835)
2' 2.8" (680)	2' 2.8" (680)	2' 9.1" (840)	2' 8.9" (835)
3' 2.2" (970)	3' 3.2" (995)	3' 8.7" (1135)	4' 4.4" (1330)
68°	68°	57°	60°
68°	68°	60°	60°
10' 3" (3135)	11' 5.4" (3490)	13' 5" (4100)	14' 8" (4480)
6' 5.6" (1970)	6' 5.6" (1970)	7' 5" (2260)	7' 7" (2320)
15.7" (400)	15.7" (400)	17.7" (450)	20.5" (520)



REFERENCE DIAGRAMS

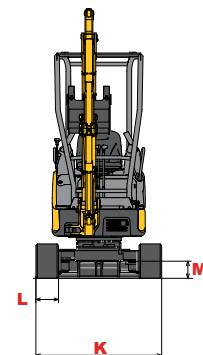
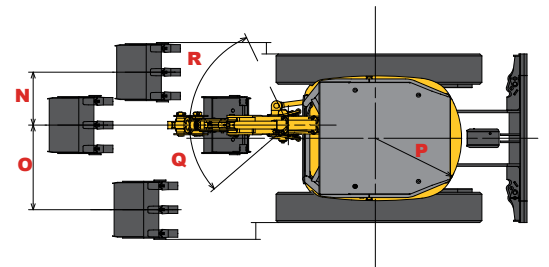
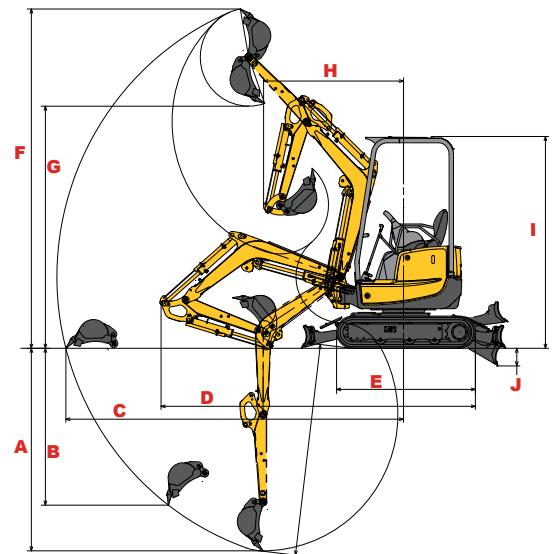

ATTACHMENTS

● ATTACHMENTS

CRAVE VERSATILITY? GEHL COMPACT EXCAVATORS ARE THE PERFECT SOLUTION.

With a wide variety of EDGE® attachments available, Gehl Compact Excavators are easily transformed to meet your needs. Perfect for landscape, utilities, construction or rental - these machines are up for any challenge.



	M08	Z17 GEN:2	Z25	Z35 GEN:2	Z45 GEN:2	Z55	Z80 GEN:2	M100
AUGERS - PLANETARY DRIVE								
PA 150H Planetary Auger Drive with top link only, Hex		●	●	●				
PA 210H Planetary Auger Drive with top link only, Hex			●	●	●	●	●	●
BREAKER								
EBX150 150 ft/lb Breaker		●						
EBX550 550 ft/lb Breaker			●	●				
EBX800 800 ft/lb Breaker					●	●	●	
EB1000 1,000 ft/lb Breaker					●	●	●	●
EB1500 1,500 ft/lb Breaker							●	●
BUCKETS								
12" (305 mm) (1.0 ft³, .028 m³) Heavy Duty Bucket	●							
24" (610 mm) (2.2 ft³, .062 m³) Heavy Duty Bucket		●						
24" (610 mm) (4.25 ft³, .12 m³) Heavy Duty Bucket			●	●				
24" (610 mm) (6.3 ft³, .178 m³) Heavy Duty Bucket					●	●		
24" (610 mm) (9.2 ft³, .261 m³) Heavy Duty Bucket							●	●
30" (762 mm) (2.7 ft³, .076 m³) Ditching Bucket		●						
48" (1219 mm) (8.5 ft³, .241 m³) Ditching Bucket			●	●	●	●		
48" (1219 mm) (15.8 ft³, .447 m³) Ditching Bucket							●	●
COMPACTION WHEEL								
CW16 16" (406 mm) Compaction Wheel			●	●	●	●		
CW122 22" (559 mm) Compaction Wheel							●	●
COMPACTION PLATE								
EC35 Compaction Plate		●	●	●				
EC65 Compaction Plate					●	●		
EC75 Compaction Plate							●	●
FROST RIPPER								
21" (533 mm) Frost Ripper			●	●				
24" (610 mm) Frost Ripper					●	●	●	●
THUMB								
Hydraulic Dual Tine Thumb			●	●	●	●	●	●

OWNER DRIVEN

Gehl authorized dealers offer a full line of compact equipment, backed up by exceptional sales, service and parts experience.

For more information on Gehl equipment, visit gehl.com

Gehl Company reminds users to read and understand the operator's manual before operating any equipment. Also, make sure all safety devices and shields are in place and functioning properly.

Gehl reserves the right to add improvements or make changes in specifications at any time without notice or obligation.



GEHL COMPACT EQUIPMENT



West Bend, WI 53095 U.S.A.
Tel: 262-334-9461 | Fax: 262-338-7517

● STANDARD ● OPTIONAL

	M08	Z17 GEN:2	Z25		Z35 GEN:2		Z45 GEN:2		Z55		Z80 GEN:2	M100
	CANOPY	CANOPY	CANOPY	CAB	CANOPY	CAB	CANOPY	CAB	CANOPY	CAB	CAB	CAB
ENGINE												
Electric Glow Plug Starting Aid	●	●	●	●	●	●	●	●	●	●	●	●
Yanmar, Naturally-Aspirated Diesel Engine	●	●	●	●	●	●	●	●			●	
Yanmar, Turbocharged Diesel Engine									●	●		●
ECO Mode & Auto Deceleration					●	●	●	●	●	●	●	●
Engine Block Heater	●	●	●	●	●	●	●	●	●	●	●	●
HYDRAULIC SYSTEM												
Power-A-Tach® Hydraulic Quick-Attach System			●	●	●	●	●	●	●	●	●	●
Factory Installed Hydraulic Thumb Attachment			●	●	●	●	●	●	●	●	●	●
Hydraulic Pumps	2	4	4	4	4	4	4	4	4	4	4	4
ISO / SAE Pattern Control Valve	●	●	●	●	●	●	●	●	●	●	●	●
Proportional Auxiliary Hydraulic Joystick Control			●	●	●	●	●	●	●	●	●	●
Two-way Auxiliary Hydraulics with Quick Couplers and Direct-to-Tank Bypass Valve	● ²	●	●	●	●	●	●	●	●	●	●	●
UNDERCARRIAGE												
Angle Blade with Float					●	●	●	●	●	●		
Bolt-On Cutting Edge					●	●	●	●	●	●		
Automatic 2-Speed Transmission											●	●
Hydraulically Extendable Undercarriage	●	●										
Rubber Tracks	●	●	●	●	●	●	●	●	●	●	●	●
Selectable 2-Speed Transmission	●	●	●	●	●	●	●	●	●	●		●
Track Rollers	2	3	4	4	4	4	4	4	4	4	5	5
UPPER STRUCTURE												
360° Continuous Movement	●	●	●	●	●	●	●	●	●	●	●	●
Zero-Tail-Swing		●	●	●	●	●	●	●	●	●	●	
Travel Alarm		●	●	●	●	●	●	●	●	●	●	●
OPERATOR STATION												
Enclosed Cab (ROPS / FOPS)				●		●		●		●	● ¹	● ¹
Canopy (ROPS / FOPS)	● ¹	●	●		●		●		●			
Fold-Up Front Window				●		●		●		●	●	●
3" Retractable Safety Belt			●	●	●	●	●	●	●	●	●	●
Adjustable Armrests - height and angle		●	●	●	●	●	●	●	●	●	●	●
Adjustable Suspension Seat			●	●	●	●	●	●	●	●	●	●
Air Conditioning						●		●		●	●	●
Radio-Ready with Speakers and Antennae				●		●		●		●	●	●
Horn	●	●	●	●	●	●	●	●	●	●	●	●
Fuel Consumption Display								●	●	●	●	●
LIGHTS												
Work Light		●	●	●	●	●	●	●	●	●	●	●
Protected Boom Light	●	●	●	●	●	●	●	●	●	●	●	●
Dome Light				●		●		●		●	●	●

1 Not FOPS compliant. 2 No tank bypass.