

MAIN FEATURES

B100C

18" tires 2-wheel steer
 1.0 m³ bucket
 97 hp
 Powershuttle Transmission (standard)
 Pilot / Mechanical Control
 3.4 litre FPT Industrial engine turbocharged,
 common rail injection
 97 hp @ 2200 rpm / 460 Nm @ 1400 rpm

SPECIFICATIONS

HYDRAULICS

Type of pump	Variable Displacement
Maximum flow	6 to 165 l/min @ 2200 l/min
Maximum pressure level	205 bars

BATTERY

12V 95Ah, 900 A (SAE) - 120 A

OPERATING WEIGHT

- with standard backhoe and 6-in-1 bucket	8120 kg
- with Extendible Backhoe and 6-in-1 bucket	8350 kg

TURNING RADIUS (front tyres 12.5/80-18, wheel not braked, 4WD engaged)

- at ext. edge of front tyres	4300 mm
- at bucket corner	5600 mm

AXLES, TYRES & BRAKE

Brakes	Power Brake with 2472 cm ² friction area
Tires can be multipurpose, hard soil specific or soft soil specific	
Tires	18" front with 26" or 28" rear
Front axle with +/- 11° oscillation	Standard
Rear axle	100% lockable

CAPACITIES

Fuel tank	145 l
Cooling system	24 l

EMISSIONS

CO ₂ emissions (g/kWh)	890
NO _x emissions	3.03
HC emissions	0.004
CO emissions	0.05
PM emissions	0.01
NO _x + NMHC emissions	3.034

NOISE

Internal (dB(A))	77
External (dB(A))	103

VIBRATION LEVELS

Upper limbs 2,5 m/s ²	2,5
Abdomen 0,5 m/s ²	0,5

BI00C TC	BI10C TC	BI15C TC
20" or 18" tires 2-wheel steer 1.2 m ³ bucket or 1.0 m ³ bucket 97 hp Powershift /Powershuttle Transmission Pilot / Mechanical Control 3.4 litre FPT Industrial engine turbocharged, common rail injection 97 hp @ 2200 rpm / 460 Nm @ 1400 rpm	20" or 18" tires 2-wheel steer 1.2 m ³ bucket or 1.0 m ³ bucket 110 hp Powershift /Powershuttle Transmission Pilot / Mechanical Control 3.4 litre FPT Industrial engine turbocharged, common rail injection 110 hp @ 2200 rpm / 460 Nm @ 1400 rpm	4 equal-sized wheel steer 1.2 m ³ bucket 110 hp Powershift Transmission (standard) Pilot / Mechanical Control 3.4 litre FPT Industrial engine turbocharged, common rail injection 110 hp @ 2200 rpm / 453 Nm @ 1400 rpm
Variable Displacement 6 to 165 l/min @ 2200 l/min 205 bars	Variable Displacement 6 to 165 l/min @ 2200 l/min 205 bars	Variable Displacement 6 to 156 l/min @ 2200 l/min 205 bars
12V 95Ah, 900 A (SAE) - 120 A	12V 95Ah, 900 A (SAE) - 120 A	12V 95Ah, 900 A (SAE) - 120 A
8270 kg 8500 kg	8270 kg 8500 kg	8870 kg 9100 kg
4300 mm 5600 mm	4300 mm 5600 mm	4300 mm 5600 mm
Power Brake with 2472 cm ² friction area	Power Brake with 2472 cm ² friction area	Power Brake with 2472 cm ² friction area
18" front with 26" or 28" rear or 20" front with 30" rear Standard 100% lockable	18" front with 26" or 28" rear or 20" front with 30" rear Standard 100% lockable	24" front with 24" or 28" front with 28" rear Standard Limited Slip Differential
145 l 24 l	145 l 24 l	145 l 24 l
890 3.03 0.004 0.05 0.01 3.034	890 3.03 0.004 0.05 0.01 3.034	890 3.03 0.004 0.05 0.01 3.034
77 103	77 103	77 103
2,5 0,5	2,5 0,5	2,5 0,5

SPECIFICATIONS

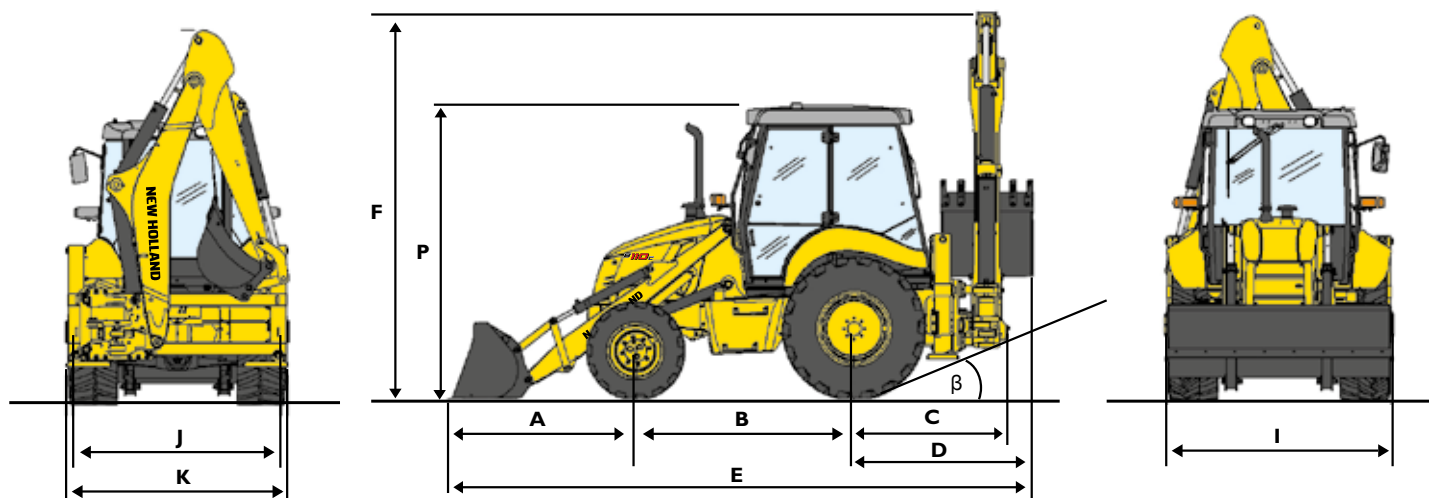

		B100C	
OVERALL DIMENSIONS			
A	Ground distance over front axle	mm	1870
B	Wheelbase	mm	2175
C	Pivot distance over rear axle	mm	1320
D	Max distance over rear axle (with 915 mm backhoe bucket)	mm	1780
E	Overall length	mm	5825
F	Height to top of boom	mm	3875
β	Back ramp angle	°	23
P	Cab height	mm	2940
I	Loader bucket width	mm	2250
J	Stabiliser width	mm	2250
K	Overall width	mm	2325
LOADER SPECIFICATIONS			
	Maximum loader breakout force	daN	6900
	Lifting capacity to maximum height	kg	3550
L	Digging depth	mm	75
M	Bucket roll back angle on ground	°	40
N	Reach at full height	mm	785
O	Maximum operating height	mm	4330
G	Hinge pin height	mm	3500
H	Maximum dump height under bucket at 45 °	mm	2780
BACKHOE SPECIFICATIONS			
	Bucket Breakout force	daN	retracted 6400
	Dipper breakout force	daN	retracted 4620 extended 3200
	Digging reach at max height	mm	retracted 2330 extended 3190
R	Bucket rotation	°	retracted 204 extended 204
S	Digging height	mm	retracted 5650 extended 6305
T	Dumping height	mm	retracted 3930 extended 4585
U	Digging reach at ground level	mm	retracted 5870 extended 6815
V	Digging depth	mm	retracted 4710 extended 5750
Z	Bucket rotation	°	retracted 203

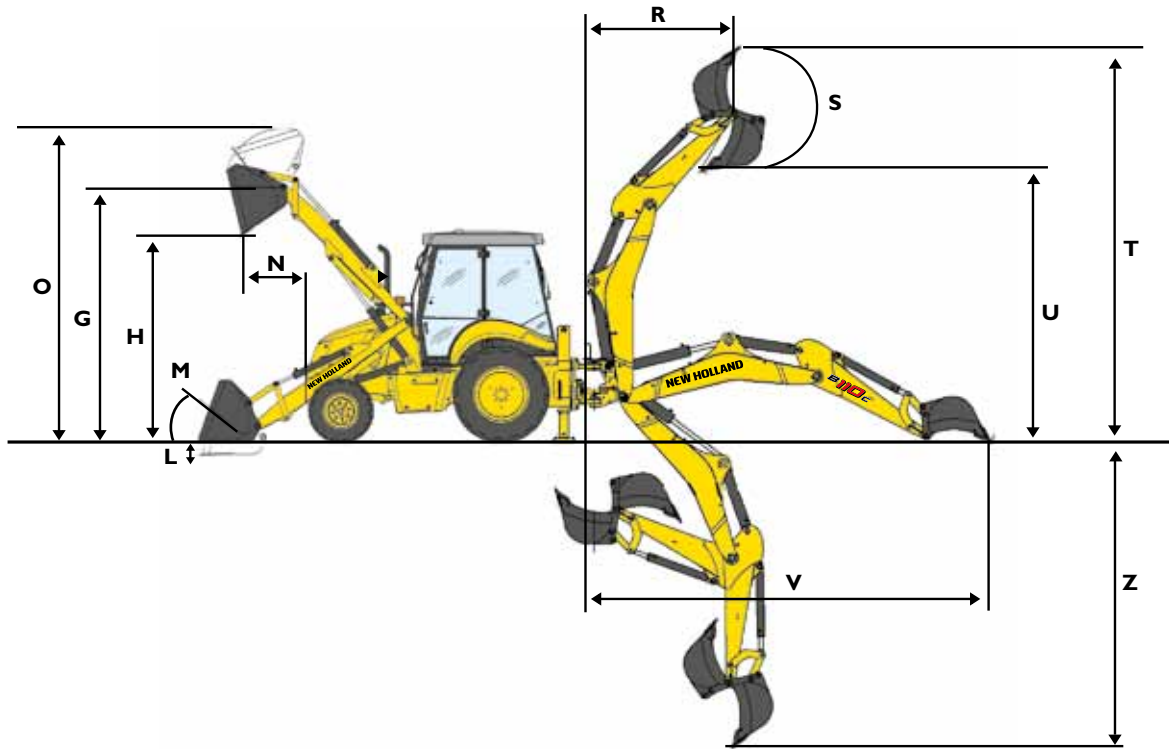

BI00CTC		BI10CTC		BI15CTC	
	1870		1870		1965
	2175		2175		2200
	1320		1320		1325
	1780		1780		1780
	5825		5825		5945
	3825		3825		3930
	23		23		22
	2940		2940		2960
	2250/2400		2250/2400		2400
	2250		2250		2250
	2325		2325		2325
	6650		6650		7400
	3195		3195		3550
	125		125		155
	46°		46°		45
	813		813		825
	4405		4405		4480
	3460		3460		3490
	2693		2693		2650
retracted	extended	retracted	extended	retracted	extended
6400		6400		6400	
4620	3200	4620	3200	4620	3200
2330	3190	2330	3190	2315	3130
204	204	204	204	204	204
5650	6305	5650	6305	5815	6475
3930	4585	3930	4585	4090	4750
5860	6815	5860	6815	5850	6810
4710	5750	4710	5750	4565	5600
203		203		203	

ATTACHMENTS OFFERING

	Width	Capacity	Weight	Hydraulics	
BUCKETS LOADER					
 6 in l  4 in l	2250 mm	1000 l	300 Kg	Hydraulic line, double acting	B100C B110C - B115C
	2400 mm	1150 l	380 Kg		
BUCKETS BACKHOE					
	305 mm	76 l	108 Kg	Not required	
	460 mm	109 l	130 Kg		
	610 mm	153 l	160 Kg		
	760 mm	196 l	180 Kg		
	915 mm	238 l	210 Kg		
DITCH CLEANING BUCKET					
	1200 mm	240 mm	170 mm	Not required	
	1500 mm	280 mm	190 mm		
V-TYPE BUCKET					
	1000 mm (Sup.)	243 l	229 kg	Not required	
	200 mm (Inf.)	150 l	160 kg		
HAMMER					
	Model	Tool dia.	Weight	Hydraulic line, single acting valve	
	CB65S CB90S	63 mm 80 mm	315 Kg 360 Kg		
SNOW BLADE					
	2640 mm	Specially designed for snow removal in tough conditions. Hydraulically powered with 30° angle to the right or left. Double acting valve is necessary.			
AUGERS					
	A complete range of augers from 150 to 1,050 mm diameter is available for each application: installation of telegraph poles, electricity pylons, signposts, pillars, tree and shrub planting. For more details contact your dealer.				

AT YOUR OWN DEALERSHIP

The information contained in this brochure is intended to be a general nature only. The NEW HOLLAND KOBELCO CONSTRUCTION MACHINERY S.p.A. company may at any time and from time to time, for technical or other necessary reasons, modify any of the details or specifications of the product described in this brochure. Illustrations do not necessarily show products in standard conditions. The dimensions, weights and capacities shown herein, as well as any conversion data used, are approximate only and are subject to variations within normal manufacturing techniques.

Printed on recycled paper
CoC-FSC 000010 CQ Mixed sources



Published by NEW HOLLAND KOBELCO CONSTRUCTION MACHINERY S.p.A
Printed in Italy - MediaCross Firenze - Cod. 31621GB - Printed 02/12



www.newholland.com

