

SPECIFICATIONS

ENGINE	
Maker / Model	CUMMINS / QS86.7
Type	Watercooled, 4-cycle, turbocharged charge aircooled, direct injection, electronic controlled diesel engine.
Gross power	149 kW (200 HP) / 2,200 rpm
Net power	147 kW (197 HP) / 2,200 rpm
Maximum torque	95 kg.m (685 lb.ft) / 1,400 rpm
No. of cylinders	6
Bore x Stroke	107 mm (4.21") x 124 mm (4.88")
Displacement	6.7 l (409 cu in)
Compression ratio	17.3 : 1
Air cleaner	Dry, two stage dual elements
Alternator	Denso (24 V - 95 A)
Battery	2 x 12 V, 900 CCA
Starting motor	Denso PA90L (24 V - 7.8 kW)

TRANSMISSION	
Torque converter type	3-elements, single-stage single-phase
Tire	20.5 R25, L3

* Full automatic power shift, countershaft type with soft-shift in range and direction. Properly matched torque converter to engine and transmission for excellent working ability.

Travel speed, km/h (mph)	4 speed T/M	5 speed T/M with lock up clutch	
Forward	1st	6.9 (4.3)	6.4 (4.0)
	2nd	11.4 (7.1)	11.1 (6.9)
	3rd	23.0 (14.3)	17.1 (10.6)
	4th	38.5 (23.9)	26.6 (16.5)
	5th	-	40.0 (24.9)
Reverse	1st	7.3 (4.5)	6.7 (4.2)
	2nd	12.0 (7.5)	11.7 (7.3)
	3rd	24.3 (15.1)	28.0 (17.4)

AXLES	
Drive system	Four-wheel drive system
Mount	Rigid front axle and oscillating rear axle
Rear axle oscillation	Oscillation $\pm 11^\circ$ of center pin-loaded
Hub reduction	Planetary reduction at wheel end
Differential	Conventional
Reduction ratio	23.680

OVERVIEW				
Description	UNIT	HL955	HL955 XT	
Operating weight	kg (lb)	15,100 (33,290)	15,600 (34,390)	
Bucket capacity	Heaped	m ³ (yd ³)	2.8 (3.6)	2.8 (3.6)
	Struck	m ³ (yd ³)	2.4 (3.1)	2.4 (3.1)
Breakout force-bucket	kg (lb)	13,000 (28,660)	12,920 (28,480)	
Tipping load	Straight	kg (lb)	11,580 (25,530)	10,080 (22,220)
	Full turn	kg (lb)	10,150 (22,380)	8,800 (19,400)

TIRES	
Type	Tubeless, loader design tires
Standard	20.5 R25, ★, L3
Options include	20.5-25, 16 PR, L2 20.5-25, 16 PR, L3 20.5-25, 16 PR, L5 17.5-25, 12 PR, L3

HYDRAULIC SYSTEM	
Type	Load sensing hydraulic system
Pump	Variable displacement piston pump, 185 lpm
Control valve	2 Spool (Bucket, Boom) 3 Spool (Bucket, Boom, Aux)
System pressure	280 kgf/cm ²
Lift Circuit	The valve has four functions; Raise / Hold / Lower / Float Can adjust automatic kickout from horizontal to full lift.
Tilt Circuit	The valve has three functions; Tilt back / Hold / Dump Can adjust automatic bucket positioner to desired load angle.
Cylinder	Type : Double acting No. of cylinders-bore x stroke; Lift: 2 - 125 mm (4.9") x 745 mm (29.3") Tilt: 1 - 140 mm (5.5") x 485 mm (19.1") Tilt: 1 - 140 mm (5.5") x 490 mm (19.3")
Cylinder	HL955 HL955 XT
Cycle Time	Raise: 5.8 sec Dump: 1.2 sec Lower: 3.8 sec Total: 10.8 sec

BRAKES	
Service Brakes	Hydraulically actuated, wet disc brakes actuate all 4 wheels independent axle-by-axle system. Self adjusting & wheel speed brake.
Parking Brake	Spring applied, hydraulic released brake
Emergency Brake	When brake oil pressure drops, indicator light alerts operator and parking brake automatically applies.

STEERING SYSTEM	
Type	Load sensing hydrostatic articulated steering
Pump	Variable displacement pump, 109 lpm
Relief Valve Setting	250 kgf/cm ²
Cylinder	Double acting 2 - 65 mm (2.6") x 418 mm (16.5")
Steering Angle	40° to both right and left angle, respectively

Features:
Center-point frame articulation. Tilt and telescopic steering column.

SERVICE REFILL CAPACITIES	
Fuel tank	250 liters (66 US gal)
DEF tank	27 liters (7.1 US gal)
Cooling system	42 liters (11.1 US gal)
Crankcase	18 liters (4.8 US gal)
Transmission	33 liters (8.7 US gal)
Front axle	32 liters (8.5 US gal)
Rear axle	24 liters (6.3 US gal)
Hydraulic tank	108 liters (28.5 US gal)
Hydraulic system (including tank)	188 liters (49.7 US gal)

DIMENSIONS			
All dimensions are approximate.			

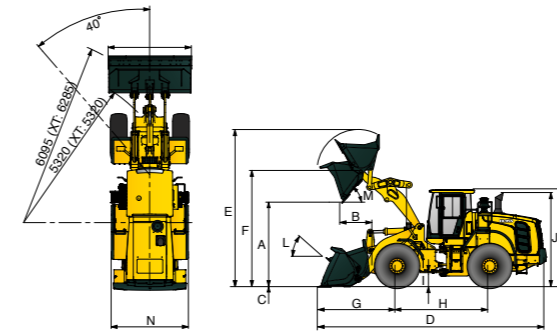

Description	UNIT	HL955	HL955 XT	
Bucket Type	General purpose bolt-on cutting edge			
A. Dumping clearance at max. height and 45° dump angle.	mm (ft-in)	2,840 (9' 3.8")	3,235 (10' 7.4")	
B. Reach	Full lift	mm (ft-in)	1,125 (3' 8.3")	1,150 (3' 9.3")
	7ft height	mm (ft-in)	1,680 (5' 6.1")	2,030 (6' 7.9")
C. Digging depth	mm (in)	85 (3.3")	120 (4.7")	
D. Overall length	on ground	mm (ft-in)	7,630 (25' 0.4")	8,040 (26' 4.5")
	at carry	mm (ft-in)	7,535 (24' 8.7")	7,985 (26' 2.4")

Description	UNIT	HL955	HL955 XT	
E. Overall height (fully raised)	mm (ft-in)	5,380 (17' 7.8")	5,780 (18' 11.6")	
F. Bucket pivot max. height	mm (ft-in)	3,940 (12' 11.1")	4,340 (14' 2.9")	
G. Front overhang	mm (ft-in)	2,625 (8' 7.3")	3,035 (9' 11.5")	
H. Wheelbase	mm (ft-in)	3,050 (10' 0.1")	3,050 (10' 0.1")	
I. Ground clearance	mm (ft-in)	410 (1' 4.1")	410 (1' 4.1")	
J. Height over exhaust	mm (ft-in)	3,273 (10' 8.9")	3,273 (10' 8.9")	
K. Height over cab	mm (ft-in)	3,390 (11' 1.5")	3,390 (11' 1.5")	
L. Roll-back angle	on ground	deg	43	43
	at carry	deg	48	48
M. Dump angle	deg	48	48	
Clearance circle (Tread)	mm (ft-in)	10,440 (34' 3.0")	10,440 (34' 3.0")	
	with bucket	mm (ft-in)	2,740 (8' 11.9")	2,740 (8' 11.9")
N. Overall width	without bucket	mm (ft-in)	2,580 (8' 5.6")	2,580 (8' 5.6")
	with bucket	mm (ft-in)	2,740 (8' 11.9")	2,740 (8' 11.9")

HL955 / DENSITY OF OPERATING MATERIALS	
Loose Material	Material Density
Earth/Clay	1.5 ~ 1.7 (2528 ~ 2865)
Sand and Gravel	1.5 ~ 1.7 (2528 ~ 2865)
Aggregate	25 ~ 76 mm (1" to 3 in) 19 mm (0.75 in) and larger
	1.6 ~ 1.7 (2697 ~ 2865) 1.8 (3034)

HL955 / DENSITY OF OPERATING MATERIALS		Material Density [t/m ³]																	
Lift arm	Bucket	Type	m ³ (yd ³)	1.0 (1686)	1.1 (1854)	1.2 (2023)	1.3 (2191)	1.4 (2360)	1.5 (2528)	1.6 (2697)	1.7 (2865)	1.8 (3034)	1.9 (3203)	2.0 (3371)	2.1 (3540)	2.2 (3708)	2.3 (3877)	2.4 (4045)	
Standard lift arm	General Purpose	Cutting edge	3.0 (3.9)	3.4 m ³ (4.4 yd ³)										2.8 m ³ (3.6 yd ³)					
		Cutting edge	2.8 (3.6)	3.1 m ³ (4.0 yd ³)										2.7 m ³ (3.5 yd ³)					
		1-Bolt on tooth	2.8 (3.6)	3.1 m ³ (4.0 yd ³)										2.7 m ³ (3.5 yd ³)					
		2-Bolt on tooth	2.8 (3.6)	3.1 m ³ (4.0 yd ³)										2.7 m ³ (3.5 yd ³)					
		1-Bolt on tooth	2.6 (3.4)	3.0 m ³ (3.9 yd ³)										2.5 m ³ (3.2 yd ³)					
		2-Bolt on tooth	2.6 (3.4)	3.0 m ³ (3.9 yd ³)										2.5 m ³ (3.2 yd ³)					
		1-Bolt on tooth & segment edge	2.8 (3.6)	3.1 m ³ (4.0 yd ³)										2.7 m ³ (3.5 yd ³)					
		2-Bolt on tooth & segment edge	2.8 (3.6)	3.1 m ³ (4.0 yd ³)										2.7 m ³ (3.5 yd ³)					
		High lift arm (XTD)	General Purpose	Cutting edge	3.0 (3.9)	3.4 m ³ (4.4 yd ³)										2.8 m ³ (3.6 yd ³)			
				Cutting edge	2.8 (3.6)	3.1 m ³ (4.0 yd ³)										2.7 m ³ (3.5 yd ³)			
1-Bolt on tooth	2.8 (3.6)			3.1 m ³ (4.0 yd ³)										2.7 m ³ (3.5 yd ³)					
2-Bolt on tooth	2.8 (3.6)			3.1 m ³ (4.0 yd ³)										2.7 m ³ (3.5 yd ³)					
1-Bolt on tooth	2.6 (3.4)			3.0 m ³ (3.9 yd ³)										2.5 m ³ (3.2 yd ³)					
2-Bolt on tooth	2.6 (3.4)			3.0 m ³ (3.9 yd ³)										2.5 m ³ (3.2 yd ³)					
1-Bolt on tooth & segment edge	2.8 (3.6)			3.1 m ³ (4.0 yd ³)										2.7 m ³ (3.5 yd ³)					
2-Bolt on tooth & segment edge	2.8 (3.6)			3.1 m ³ (4.0 yd ³)										2.7 m ³ (3.5 yd ³)					

115% 100% 95%

CABIN & INTERIOR	STD	OPT
Alternator, 95 A	●	
Alarms, audible and visual		
Air filter clogging	●	
Transmission error	●	
Battery voltage	●	
Brake oil pressure	●	
Engine oil pressure	●	
Parking brake	●	
Fuel level	●	
Hydraulic oil temperature	●	
Coolant temperature	●	
Transmission oil temperature	●	
Service brake oil pressure	●	
Coolant level	●	
Water in fuel	●	
Alarm, back-up	●	
Batteries, PT		
900 CCA, 12 V, (2)	●	
Gauges		
Engine coolant temperature	●	
Fuel level	●	
Speedometer	●	
Transmission oil temperature	●	
Horn, electric		
Indicator lights		
T/C lock up		●
High beam	●	
Turn signal	●	
FNR joystick steering		●
Pilot cut off	●	
LCD Display		
Clock and fault code	●	
Operating hour counter	●	
Engine rpm	●	
Transmission gear range	●	
Indicator	●	
Job time and distance	●	
Temperature (coolant, hydraulic oil, t/m oil)	●	
Lighting system		
LED dome light	●	
2 stop and tail lights	●	
4 turn signals	●	
Brake lights (counterweight)	●	
2 head lights on front tower	●	
2 working lights on front roof	●	
4 working lights on front roof, 2 working lights on rear roof		●
4 working lights (2 xenon) on front roof, 2 working lights on rear roof		●
4 working lights (LED) on front roof, 2 working lights (LED) on rear roof		●
2 working lights on grill	●	
Switches		
Hazard	●	
Ignition	●	
Parking	●	
Battery master switch	●	
FNR	●	
Diff, lock	●	
SCR cleaning / inhibit	●	
Secondary steering test		●
Pilot cut off	●	
Membrane Switches in monitor		
Main light	●	
Work light	●	
Auto grease		●
Quick coupler		●
Ride control	●	
Work load	●	
Beacon lamp		●
Rear wiper	●	
Mirror heat		●
Auto position	●	
Fine modulation	●	

CABIN & INTERIOR	STD	OPT
Cab (sound suppressed and pressurized) with		
Cigar lighter & ashtray	●	
Coat hook	●	
Automatic climate control		
Air conditioner & heater	●	
Defroster	●	
Intermittent wiper and washer, front and rear	●	
Seat		
2" retractable seat belt & adjustable	●	
2" static seat belt & adjustable mechanical suspension (heated)		●
3" static seat belt & adjustable mechanical suspension		●
2" retractable seat belt & adjustable air suspension (heated)		●
Personal storage space		
Console box	●	
Holder, can and cup	●	
Rear view mirrors (1 inside)	●	
Rear view mirrors (2 outside)	●	
Rear view mirrors (2 outside, Heated)		●
Steering column, tilt and telescopic	●	
Steering wheel with knob	●	
Roller type sunshade (front window)	●	
Roller type sunshade (rear window)		●
Tinted safety glass	●	
One door cab	●	
Magazine pocket	●	
Pedals		
One accelerator pedal	●	
One brake pedal	●	
Dual-Brake pedal		●
Radio/USB player	●	
Rubber floor mat	●	
Wrist rest	●	
24-volt to 12-volt DC converter (20A)		●
ENGINE		
Antifreeze	●	
Engine, Cummins QSB6.7		
Tier 4 Final / Stage 4	●	
Engine enclosure, lockable	●	
Engine fuel priming pump	●	
Fan guard	●	
Fuel/water separator	●	
Clean emission module		
DOC and SCR	●	
Rain cap, engine air intake	●	
3 Stage air precleaner		●
Radiator	●	
Starting aid (air intake heater)	●	
Fuel heater	●	
Fuel heater (Dual)		●
Coolant level sight gauge	●	
Engine oil level dipstick gauge	●	
Air cleaner with auto dust eject	●	
POWER TRAIN		
Brakes : Service, enclosed wet-disc	●	
Parking brake	●	
Torque converter	●	
Transmission F4 / R3, computer controlled, electronic soft shift, auto-shift and kick-down features included		●
Transmission F5 / R3 with lock-up clutch	●	
Transmission oil sight level	●	
Limited slip differential (front, rear)		●
Transmission oil cooler	●	
Transmission oil cooler with thermostat		●
Hydraulic lock differential (front)		●
Front axle cooling system		●

POWER TRAIN	STD	OPT
Tires		
20.5 R25, L3	●	
20.5 - 25, 16PR, L3		●
20.5 - 25, 16PR, L2		●
20.5 - 25, 16PR, L5		●
20.5 R25, XHA2		●
17.5 - 25, 12PR, L3		●
Travel speed limiter (20-40 km/h)		●
HYDRAULIC SYSTEM		
Boom kickout, automatic	●	
Bucket positioner, automatic	●	
Diagnostic pressure taps	●	
Hydraulic oil cooler	●	
Hydraulic control, 2 spool		●
Hydraulic control, 3 spool	●	
Joystick Control (EH control)		●
Lever control-single axle (EH control)		●
Joystick Steering		●
Ride control system	●	
Secondary steering system	●	
Extra piping-for auxiliary function		●
Quick coupler piping		●
Auto grease system		●
OTHER		
Articulation locking bar	●	
Counterweight	●	
Optional counter weight		●
Door and cab locks, one key	●	
Doors, service access (locking)	●	
Drawbar with pin	●	
Ergonomically located and slip resistant, left & right	●	
Handrails	●	
Ladders	●	
Platforms	●	
Steps	●	
Fenders (front / rear)	●	
Hydraulic oil level sight gauge	●	
Lift and tie-down hooks	●	
Loader linkage, sealed	●	
Z-bar design	●	
Vandalism protection caplocks	●	
Tool kit		●
Cutting edge, bolt-on type	●	
Tooth, 1 piece, bolt-on type		●
Tooth, 2 pieces, bolt-on type		●
Pallet forks		●
Guards		
Crankcase		●
Transmission	●	
Mud guards	●	
Wheel chock	●	
License plate & lamp		●
Hi MATE (Remote Management System)	●	
Rearview camera	●	
SAFETY		
Beacon light, rotating		●
Fire extinguisher		●
Operator suit		●

STD = Standard
OPT = Optional

- * Standard and optional equipment may vary. Contact your Hyundai dealer for more information.
- The machine may vary according to International standards.
- * The photos may include attachments and optional equipment that are not available in your area.
- * Materials and specifications are subject to change without advance notice.
- * All imperial measurements rounded off to the nearest pound or inch.
- * The air conditioning system on this machine contains the fluorinated greenhouse gas refrigerant HFC-134a (Global Warming Potential = 1430). The system contains 0.75 kg of refrigerant which has a CO₂ equivalent of 1.0725 metric tonne.