

## Dimensions

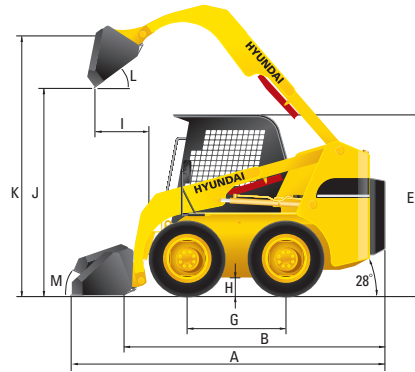
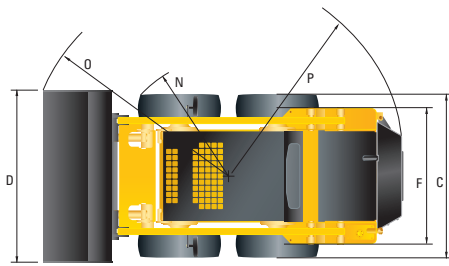

## Specifications

DESCRIPTION		UNIT	HSL650-7A	HSL850-7A
Nominal capacity		kg (lb)	650 (1,433)	860 (1,892)
Tipping load		kg (lb)	1,310 (2,888)	1,718 (3,780)
Operating weight		kg (lb)	2,690 (5,787)	3,355 (7,381)
ENGINE	Model	-	Kubota V2403	Kubota V3307-T
	Gross output	kW (HP)	35.5 (48.3)	55.4 (75.3)
	Net output	kW (HP)	34.3 (46.6)	53.5 (72.7)
	Rated engine speed	rpm	2,500	2,400
GENERAL	Travel controls	-	Pilot operated joystick	Pilot operated joystick
	Attachment controls	-	Pilot operated joystick	Pilot operated joystick
	Tires	-	10-16.5,6PR	12-16.5,12PR
Max. travel speed		km/h (mph)	11.5 (7.1)	11.4 (7.1)
HYDRAULICS	Hydraulic pump flow	ℓ/min (gpm)	66.3 (17.5)	63.9 (16.9)
	Max. hydraulic pressure	kg/cm <sup>2</sup> (psi)	175 (2,489)	175 (2,489)
DIMENSIONS	Overall length (with bucket)	A	3,270 (128.7)	3,470 (136.6)
	Overall width (without bucket)	C	1,515 (59.6)	1,830 (72.0)
	Overall height (attachment lowered)	E	1,965 (77.4)	2,000 (78.7)
	Tread	F	1,255 (49.4)	1,500 (59.1)
	Wheelbase	G	990 (39.0)	1,100 (43.3)
	Overall length (without bucket)	B	2,625 (103.3)	2,840 (111.8)
	Ground clearance	H	183 (7.2)	205 (8.1)
	Turn radius, bucket	O	1,935 (76.2)	2,080 (81.9)
	Turn radius, front tire	N	1,260 (49.6)	1,300 (51.2)
	Turn radius, rear end	P	1,560 (61.4)	1,660 (65.4)
	Rear departure angle	-	28°	28°
	Height to bucket pin	K	2,915 (114.8)	3,080 (121.3)
	Max. dump height	J	2,240 (88.2)	2,410 (94.9)
	Max. bucket dump angle	L	45°	45°
	Reach at max. dump	I	550 (21.7)	510 (20.1)
	Max. bucket rollback angle	M	27°	27°
	Bucket width	D	1,625 (64.0)	1,894 (74.6)
	Bucket capacity (heaped)	m <sup>3</sup> (ft <sup>3</sup> )	0.31 (10.9)	0.37 (13.1)
	Fuel tank capacity	ℓ (gal)	60 (16)	83 (22)
Hydraulic tank capacity	ℓ (gal)	38 (10)	57 (15)	

## Standard Equipment

- Hand throttle lever
- Direct cooling system
- Dual airfilter
- Aux. piping (3-spool)
- Pilot operated joysticks (travel + attachment)
- Bow tie drive chain
- Dashboard integrated in roof
- ROPS / FOPS certified canopy
- Inside rearview mirror
- Vandalism protection
- Spark arresting muffler (only for HSL850-7A)
- Seat bar

## Optional Equipment

- Cyclone type air prefilter
- Parallel bucket lift
- Master switch
- Backup alarm
- ROPS / FOPS certified cabin
- Heater
- Air-con & heater
- Defroster
- Fenders
- Side mirrors
- Directional indicators
- Beacon
- Rear working light
- High flow attachment control

\* Standard and optional equipment may vary.  
Contact your Hyundai dealer for more information.  
The machine may vary according to International standards.

\* The photos may include attachments and optional equipment that are not available in your area.

\* Materials and specifications are subject to change without advance notice.

\* All imperial measurements rounded off to the nearest pound or inch.

 **HYUNDAI**  
HEAVY INDUSTRIES EUROPE  
**CONSTRUCTION EQUIPMENT**

Hyundai Heavy Industries Europe N.V.  
VOSSENDAAL 11, 2440 GEEL, BELGIUM TEL: (32) 14-56-2200 FAX: (32) 14-59-3405

PLEASE CONTACT