

2420

Vibratory Soil Compactor.

Rugged, Reliable, Proven



Specifications 2420

Technical Data	2420	2420	2420 PD
	Standard	Drum Drive	
WEIGHTS			
Maximum Weight	kg 11950	12150	12150
Operating Weight	kg 11430	11630	11630
Weight On Drum	kg 6600	6800	6800
Weight On Tyres	kg 4830	4830	4830
Static Linear Load Front	kg/cm 30.8	31.8	-
DIMENSIONS			
Working Width	2140	2140	2140
Drum Diameter	1500	1500	1484
Turning Radius Outside/Inside	6340/4200	6340/4200	6340/4200
Pad Feet No.	-	-	140
Pad Feet Height	-	-	150 mm
Pad Feet Area	-	-	146 cm ²
ENGINE			
	HA 694		
Make	KOEL		
Specification	Air Cooled, 6 Cylinder(meeting Bharat Stage II (CEV) (Emission Norms)		
Rated power	82 KW / 112 HP AT 2500 RPM		
DRIVE			
Hydrostatic Drive, Infinitely Variable Planetary Axle With No-spin Differential	Rear Wheel	All-wheel	All-wheel
SPEED			
Working Speed	Km/h 0-10.3	0-7.2	0-8
Travelling Speed	Km/h 0-19.7	0-13.6	0-16.0
GRADEABILITY			
Max. Gradeability	% 31	40	40
VIBRATION SYSTEM			
Hydrostatic Drive, Proportional Control			
Frequency	33 Hz/42 Hz	33 Hz/42 Hz	33Hz/42Hz
Nominal Amplitude	1.9 mm/0.8 mm	1.9 mm/0.8 mm	1.9mm/0.8mm
STEERING			
	Articulated Hydrostatic Steering		
Frame Steering	± 30°	± 30°	± 30°
Oscillation Angle	± 10°	± 10°	± 10°
BRAKES			
Service Brake	Hydrostatic		
Parking Brake	Spring applied hydraulically released (SAHR)		
Emergency Stop	Hydrostatic drive & spring applied brake		
TYRES			
Profile Tyres AW 23.1 / 18 - 26 12PR			
TANK CAPACITY			
Fuel Tank Capacity	235 ltr	235 ltr	235 ltr
Hydraulic Oil Tank Capacity	80 ltr	80 ltr	80 ltr
ELECTRICAL SYSTEM			
Operating Voltage 12 v, 150Amh.			
STANDARD FITMENT			
Canopy, spring suspended operator platform, access from both sides, cushioned seat, pilot lights back-up alarm, instrument panel with a range of control instruments including hour meter, light equipment.			
SAFETY FEATURES			
Neutral start switch, air filter clog indicator, hydraulic filter clog indicator, v - belt failure warning horn.			
OPTIONAL FITMENT			
Standard ROPS, cab with roof & window, windscreen wiper front, mirrors outside/inside, cab heating, air-conditioning, sun screen, interior light, flashing beacon, compactometer, documentation system & tachograph, safety belt.			

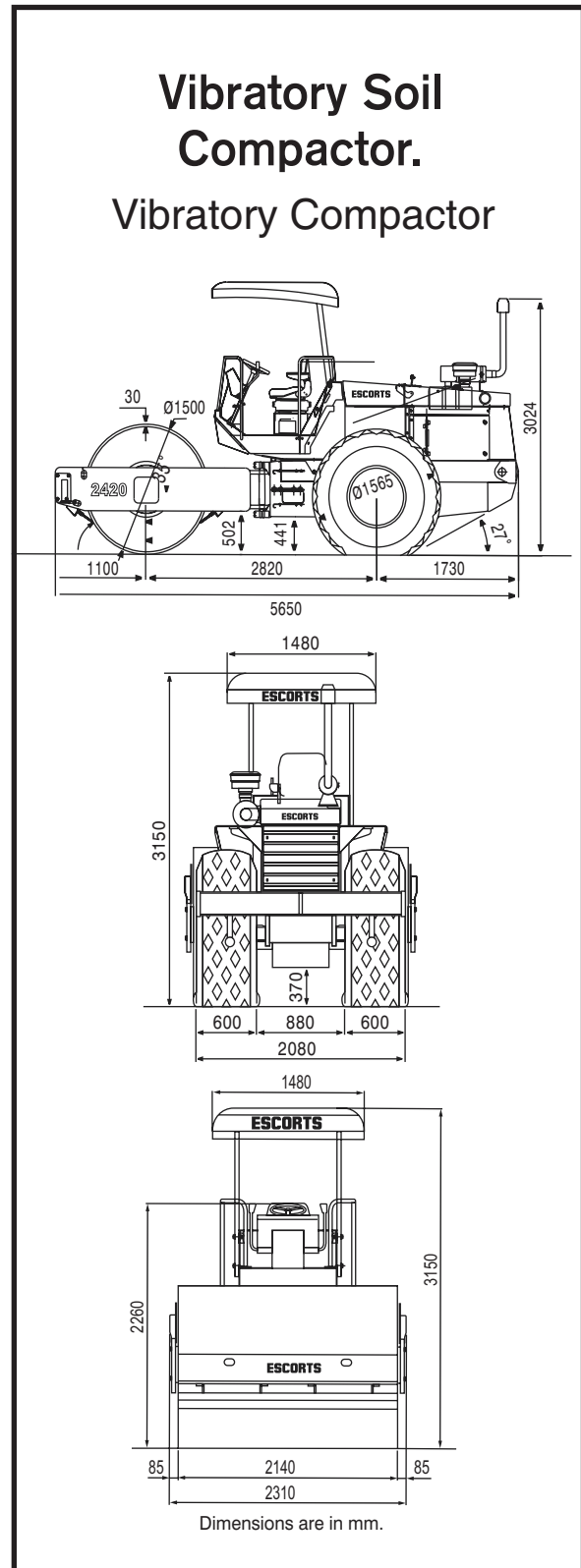

LIT/MKTG/2420/01-12



Escorts Construction Equipment Limited

Plot No. 219, Sector-58, Ballabgarh, Faridabad (Haryana) - 121 004, INDIA
 Tel.: (0129) 2306300/2306570, Toll free no :1800-180-1890, Fax: (0129) 2306463
 E-mail: marketing@escorts-ecl.com
 Website: www.ecl.com

Dealer Stamp/ Address

• The information contained in this leaflet is intended to be of a general nature only. • We reserve the right to change specifications without notice. • All Dimensions and Weights are variable within ± 2.5%