

**ESCORTS  
CONSTRUCTION EQUIPMENT**



**RUGGED  
RELIABLE  
EFFICIENT**

**EC 2420  
VIBRATORY SOIL COMPACTOR**

## SPECIFICATIONS

Technical Data	Units	2420-STD	2420-DD	2420-PD
<b>WEIGHT</b>				
Maximum operating Weight	Kg	12100	12300	12300
Operating Weight	Kg	11790	11990	11990
Weight on Drum	Kg	6960	7160	7160
Weight on Tyres	Kg	4830	4830	4830
Static Linear Load Front	Kg/Cm	32.5	33.5	-
Centrifugal Force	Kg	26032	26032	26032
Max. Applied Force	Kg	32992	33192	33192
<b>DIMENSIONS</b>				
Overall Width	mm	2310	2310	2310
Overall Length	mm	5520	5520	5520
Overall Height	mm	3045	3045	3045
Drum Diameter	mm	1500	1500	1500
Drum Width	mm	2140	2140	2140
Ground Clearance	mm	435	435	435
Wheel Base	mm	2820	2820	2820
Turning Radius-outer/inner	mm	6480/4340	6480/4340	6480/4340
Pad Foot No	No's	-	-	-
<b>ENGINE</b>				
<b>HA 494</b>				
Make		KOEL		
Specification		6 Cylinder, Air Cooled, Bharat Stage III (CEV) Emission Norms		
Rated power		102 hp at 2500 Rpm		
<b>DRIVE</b>				
Hydrostatic Drive ,Infinitely Variable		Rear Wheel	All-Wheel	All-Wheel
Planetary Axle with No-spin Differential				
<b>VIBRATION SYSTEM</b>				
Hydrostatic Drive				
Frequency	Hz	33/42	33/42	33/42
High Amplitude	mm	1.9	1.9	1.9
Low Amplitude	mm	0.8	0.8	0.8
<b>SPEED</b>				
Working Speed	Km/hr	0-9	0-6	0-6
Travelling Speed	Km/hr	0-23	0-10	0-10
<b>GRADEABILITY</b>				
Max Gradeability	%	30	40	40
<b>STEERING</b>				
Articulated Hydrostatic Steering				
Steering Angle		±30°		
Oscillation Angle		±10°		
<b>BRAKES</b>				
Service Brake		Hydrostatic		
Parking Brake		Spring applied Hydraulically Released		
Emergency Stop		Hydrostatic Drive & Spring Applied Brake		
<b>TYRES</b>				
2 Nos. All Weather Pattern		23.1/26-12 PR		
<b>TANK CAPACITY</b>				
Fuel Tank Capacity	Lts	300		
Hydraulic Oil Tank Capacity	Lts	80		
<b>ELECTRICAL SYSTEM</b>				
Operating Voltage 12V, 150Amh.				
<b>STANDARD EQUIPMENT</b>				
Canopy with Sun Top, Cushioned Seat, Rear View Mirror, Instrument Panel With a range of Control instruments including Hour Meter, Light Equipment, Lifting Eyes, Tool Box, Brake Warning Light.				
<b>SAFETY FEATURES</b>				
Neutral Start Switch, Air Filter Clog Indicator, Hydraulic Filter Clog Indicator, V-belt Failure auto engine shut off Reverse Buzzer.				
<b>OPTIONAL FITMENT</b>				
Operator Cabin, Cold Starting Kit, Engine Cut-off at High Temperature & Low Pressure, Compactobar with frequency meter.				

## VIBRATORY SOIL COMPACTOR

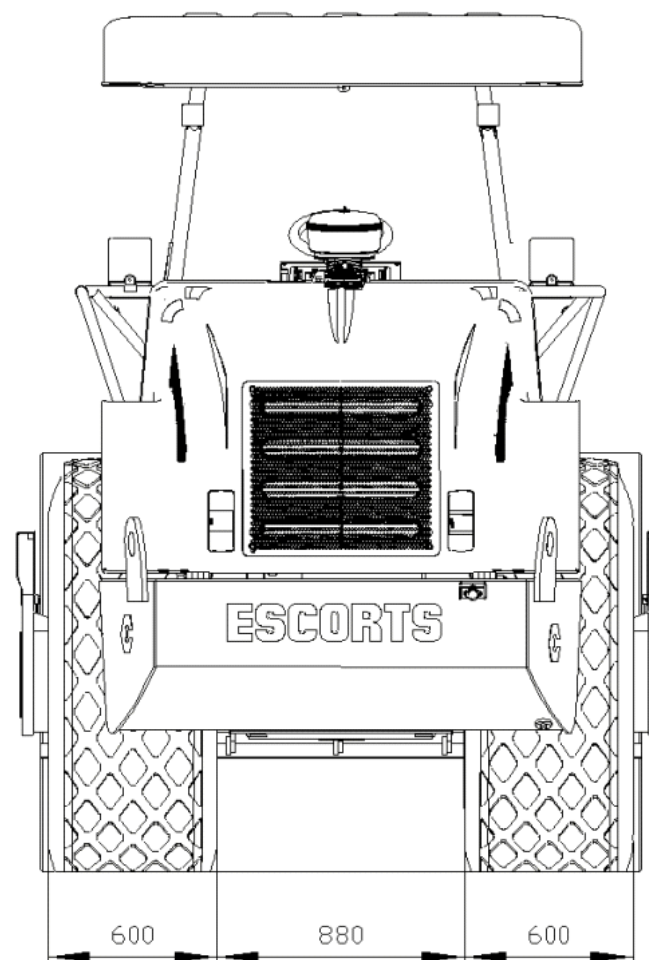
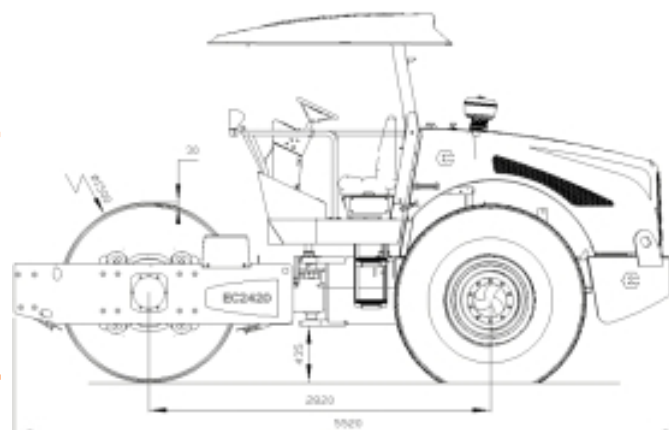

LIT / MKTG / EC 2420 / 14-15

The information contained in this leaflet is intended to be of general nature only. We reserve the right to change the specifications without any prior notice. All dimensions and weights are variable with in ±2.5%



**ESCORTS  
CONSTRUCTION EQUIPMENT**

Escorts Limited Plot No. 219, Sector 58, Ballabgarh-121 004, Haryana, India, Tel.: +91 129 2306300, Fax: +91 129 2306463, e-mail: exports.ece@escorts.co.in  
www.escortsece.com