



CLG 614 Roller



Engine	Shangchai
Gross Power	95 kW @ 2,050 rpm
Vibration Frequency Range	30 Hz
Centrifugal Force Range	270 kN / 135 kN
Working Width	2,130 mm
Operating Weight	14,000 kg

CLG614

Single Drum Vibratory Roller



ENGINE

Emission Regulation	Tier 2 / Stage II
Make	Shangchai
Gross Power	95 kW @ 2,050 rpm
Peak Torque	490 N.M
Number of Cylinders	4
Aspiration	turbocharged
Cooling Type	water

ELECTRICAL SYSTEM

System Voltage	24 V
----------------	------

DRIVE TRAIN

Theoretical Gradeability, without/with Vibration	30 %
Transmission Type	synchronous shift
1 st Maximum Speed, fwd	2.6 km/h
2 nd Maximum Speed, fwd	5.2 km/h
3 rd Maximum Speed, fwd	11 km/h
Inside Turning Radius	<4,370 mm
Outside Turning Radius	<6,500 mm

AXLES

Steering System	hydraulic
Steering Method	articulation
Steering Angle	± 35°
Steering Relief Pressure	16 MPa

BRAKES

Service Brake Type	caliper disc
Service Brake Actuation	air over hydraulic
Parking Brake Actuation	spring apply; mechanical release

TIRES

Tire Size	20.5 - 25 - 16 PR
Tire Tread	L - 3

HYDRAULIC SYSTEM

Main Pump Type	gear pump
Main Relief Pressure	180 bar

PERFORMANCE

Static Linear Front Drum Load	328 kg-mm
Number of Vibrating Drums	1
Nominal Amplitude Range	1.75 / 0.85 mm
Vibration Frequency Range	30 Hz
Centrifugal Force Range	270 / 135 kN
Number of Amplitude Settings	1

OPERATING WEIGHTS

Operating Weight with Ballast	14,000 kg
Weight on Front Drum	7,150 kg
Weight on Tires	6,850 kg

SERVICE CAPACITIES

Fuel Tank	285 L
Engine Oil	14 L
Cooling System	32 L
Transmission and Torque Converter	14.5 L

OPTIONAL EQUIPMENT

- Padfoot Drum Segment Kit (PDH)
- Rotary Beacon
- Backup Alarm
- Air-Conditioner
- Rhombic Pattern Tyre

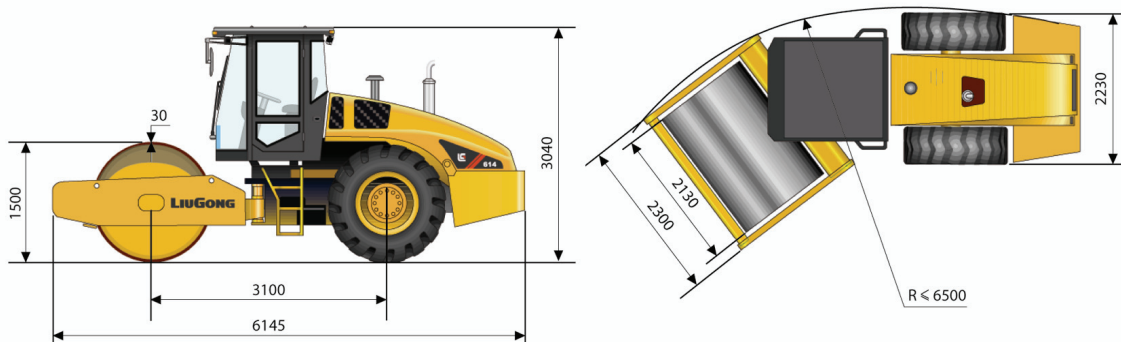

Unit: mm

Guangxi Liugong Machinery Co., Ltd.

No. 1 Liutai Road, Liuzhou, Guangxi 545007, PR China

T: +86 772 388 6124 E: overseas@liugong.com

www.liugong.com

Specifications and designs are subject to change without notice. Machines shown may include optional equipment.