



# ASC 70

SOIL COMPACTOR  
Tier 3

## EFFICIENT WITH HIGH OUTPUT

The Ammann ASC 70 Tier 3 Soil Compactor provides efficient compaction through the optional ACE<sup>force</sup> system. Compaction is maximised through the Ammann vibratory system and varied amplitude settings. The roller is best suited to small and medium jobsites and delivers industry-leading compaction outputs. An HT and HD version excels on jobsites where high tractive efforts are required.

## OPTIONAL ACE<sup>force</sup> TECHNOLOGY

- Provides measurement and documentation
- Precisely measures and evaluates material stiffness
- Shows compaction progress via operator-guiding function
- Includes ADS documentation software with office analyzing feature
- Can utilise all major manufacturers GPS products to provide mapping and operator guidance

## EASY ACCESS

- Easily accessible maintenance points
- Optionally centralized draining points for service fluids

## OPERATOR FRIENDLY

- Clear dashboard layout ensures easy and safe operation
- Operator platform is mounted on vibration-free rubber mounts for highest comfort

## INDUSTRY-LEADING COMPACTION

- Utilises effective Ammann vibratory system
- Offers varied amplitude settings
- Drives energy into the material and away from the operator

## APPLICATIONS

- Small and medium jobsites
- Transport construction (municipal roads, local infrastructure)
- Building construction (industrial zones, residential zones)

MAXIMUM RECOMMENDED COMPACTED LIFT THICKNESS AT OPTIMAL WORKING CONDITIONS

	Rockfill	Sand / Gravel	Mixed Soils	Silt	Clay
ASC 70 D	-	*0.45 m (18 in)	*0.35 m (14 in)	0.25 m (10 in)	0.15 m (6 in)
ASC 70 PD	-	-	*0.35 m (14 in)	*0.25 m (10 in)	*0.2 m (8 in)

\*Recommended drum type

**AMMANN**

TECHNICAL SPECIFICATIONS  
ASC 70 SOIL COMPACTOR  
Tier 3

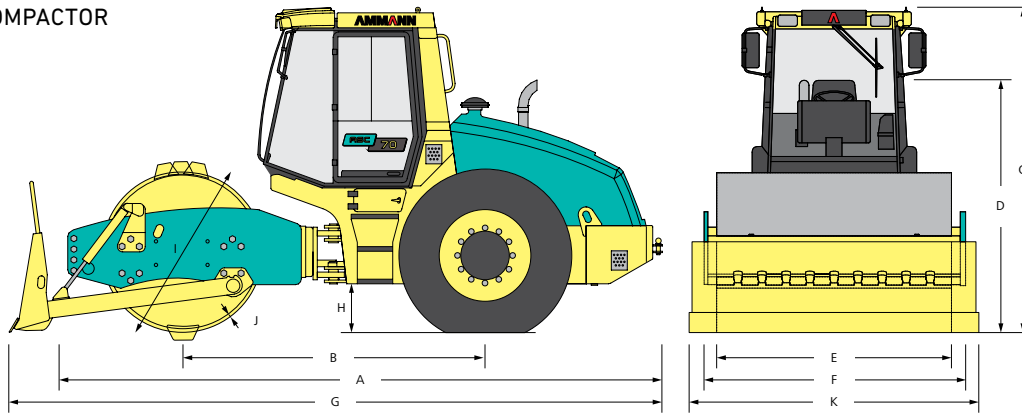

**DIMENSIONS**

	D	PD
A MACHINE LENGTH	5195 mm (204.6 in)	5195 mm (204.6 in)
B WHEELBASE	2560 mm (100.8 in)	2560 mm (100.8 in)
C MACHINE HEIGHT	2870 mm (113 in)	2870 mm (113 in)
D MACHINE HEIGHT (REMOVED CAB / ROPS)	2280 mm (89.8 in)	2280 mm (89.8 in)
E DRUM WIDTH	1680 mm (66.2 in)	1680 mm (66.2 in)
F MACHINE WIDTH	1720 mm (67.8 in)	1720 mm (67.8 in)
G MACHINE LENGTH (BLADE)	-	5555 mm (218.8 in)
H GROUND CLEARANCE	385 mm (15.2 in)	385 mm (15.2 in)
I DRUM DIAMETER	1300 mm (51.2 in)	1400 mm (55.1 in)
J DRUM SHELL THICKNESS	25 mm (1 in)	15 mm (0.6 in)
K MACHINE WIDTH (BLADE)	-	2215 mm (87.3 in)

**MISCELLANEOUS**

BRAKES OPERATING	Hydrostatic
BRAKES PARKING	Multiple-disc spring brake
BRAKES EMERGENCY	Multiple-disc spring brake
FUEL TANK CAPACITY	275 l (72.65 gal)
VOLTAGE	24 V

**WEIGHT & OPERATING CHARACTERISTICS**

	D	HT	HD	PD	HTPD	HDPD
OPERATING WEIGHT	7140 kg (15 740 lb)	7620 kg (16 800 lb)	7140 kg (15 740 lb)	7090 kg (15 630 lb)	7570 kg (16 690 lb)	7090 kg (15 630 lb)
MAXIMUM WEIGHT	9260 kg (20 410 lb)	9740 kg (21 470 lb)	9260 kg (20 410 lb)	8120 kg (17 900 lb)	8600 kg (18 960 lb)	8120 kg (17 900 lb)
STATIC LINEAR LOAD	23.9 kg/cm (133.8 lb/in)	24.3 kg/cm (136.1 lb/in)	23.9 kg/cm (133.8 lb/in)	-	-	-
MAX. TRANSPORT SPEED	11 km/h (6.8 MPH)	8.4 km/h (5.2 MPH)	10 km/h (6.2 MPH)	11.1 km/h (6.9 MPH)	8.5 km/h (5.3 MPH)	10.1 km/h (6.3 MPH)
MAX. WORKING SPEED	4.7 km/h (2.9 MPH)	3.6 km/h (2.2 MPH)	4.4 km/h (2.7 MPH)	4.8 km/h (3 MPH)	3.7 km/h (2.3 MPH)	4.5 km/h (2.8 MPH)
CLIMBING ABILITY	45 %	60 %	55 %	45 %	60 %	55 %
TURNING RADIUS INNER (EDGE)	3090 mm (121.7 in)	3090 mm (121.7 in)	3090 mm (121.7 in)	3090 mm (121.7 in)	3090 mm (121.7 in)	3090 mm (121.7 in)

**STANDARD EQUIPMENT**

- Operator platform with guard rails
- Smooth drum with steel scrapers
- 2 vibration frequencies and amplitudes
- Inter wheel Differential-lock
- Manual tilting of hood/cab/platform
- Working headlights (front and rear)

**COMPACTION FORCES**

	D / HT / HD	PD / HTPD / HDPD
FREQUENCY I	30 Hz (1800 VPM)	30 Hz (1800 VPM)
FREQUENCY II	41 Hz (2460 VPM)	41 Hz (2460 VPM)
FREQUENCY ACE MIN./MAX.	-	-
AMPLITUDE I	1.7 mm (0.067 in)	1.7 mm (0.067 in)
AMPLITUDE II	0.86 mm (0.034 in)	0.86 mm (0.034 in)
AMPLITUDE ACE MIN./MAX.	-	-
CENTRIFUGAL FORCE I	145 kN	145 kN
CENTRIFUGAL FORCE II	130 kN	130 kN
CENTRIF. FORCE ACE MIN./MAX.	-	-

**ENGINE**

MANUFACTURER	Cummins QSB 3.3-C99
POWER ACCORDING TO ISO 3046-1	74 kW (99 HP)
MAXIMUM TORQUE	412/1600 Nm/rpm
ENGINE COMPLIES WITH EMISSION REGULATIONS	EU Stage IIIA, U.S. EPA Tier 3

**OPTIONAL EQUIPMENT**

- CE conformity
- Cab ventilated and heated (incl. FOPS I)
- ROPS structure
- Air condition for Cab version
- Ammann Traction Control (ATC)
- Padfoot drum or padfoot segments
- Dozer blade
- HD and HT versions
- ACE<sup>force</sup> compaction measurement (absolute values) and ADS documentation system
- GPS mapping for ACE systems