



Cat® CS68B

SMOOTH DRUM VIBRATORY SOIL COMPACTOR

FEATURES:

The Cat® CS68B features a smooth drum and is ideally suited for granular soil applications:

- **Comfortable and ergonomic operator station** features pivoting seat with integrated multifunction LCD display and control console, outstanding visibility to the front and rear of machine, low sound levels and vibration for greater operator comfort and productivity.
- **World-class propel system** built around the exclusive Cat dual pump propel system, two pumps provide separate dedicated flow to drum drive motor and rear axle motor for exceptional gradeability and traction in forward and reverse. New electronic propel control enables more precise machine control.

- **Virtually maintenance free** due to maintenance-free hitch bearings and extended maintenance intervals for vibratory system and hydraulic system, providing more uptime and lower maintenance costs.
- **Enhanced compaction performance** due to more weight at the drum and greater amplitude. Automated propel and vibratory system functions make it easy to ensure consistent, high quality.
- **Optional Cat® Compaction Control** helps the operator determine when compaction has been completed to specification for greater productivity and uniform compaction quality.

Specifications

Engine - Power Train

| | | |
|--|------------------------------|-----------------------|
| Engine Model | Cat® C4.4 with ACERT™ | |
| Global Emissions | US EPA Tier 4i/EU Stage IIIB | |
| Gross Power ISO 14396 | 117 kW | 157 hp |
| Displacement | 4.4 L | 268.5 in ³ |
| Stroke | 127 mm | 5 in |
| Bore | 105 mm | 4.1 in |
| Max. Travel Speed (Forward or Reverse) | 11.4 km/h | 7 mph |

Weights

| | | |
|---|-----------|-----------|
| Operating Weight w/ ROPS/FOPS cab | 14 325 kg | 31,572 lb |
| w/ padfoot shell kit | 15 730 kg | 34,662 lb |
| w/ leveling blade | 14 980 kg | 33,011 lb |
| w/ padfoot shell kit and leveling blade | 16 380 kg | 36,101 lb |
| Weight at Drum w/ ROPS/FOPS cab | 9150 kg | 20,164 lb |
| w/ padfoot shell kit | 10 550 kg | 23,247 lb |
| w/ leveling blade | 10 105 kg | 22,271 lb |
| w/ padfoot shell kit and leveling blade | 11 505 kg | 25,354 lb |

Vibratory System Specifications

| | | |
|--|--------------|---------------|
| Frequency | | |
| Standard | 30.5 Hz | 1830 vpm |
| During Eco-mode Operation | 27.7 Hz | 1664 vpm |
| Optional Variable Frequency | 23.3-30.5 Hz | 1400-1830 vpm |
| Nominal Amplitude @30.5 Hz (1830 vpm) | | |
| High | 2.1 mm | 0.083 in |
| Low | 0.98 mm | 0.039 in |
| Centrifugal Force @ 30.5 Hz (1830 vpm) | | |
| Maximum | 301 kN | 67,600 lb |
| Minimum | 141 kN | 31,670 lb |
| Static Linear Load | | |
| w/ ROPS/FOPS Cab | 42.9 kg/cm | 240 lbs/in |

Service Refill Capacities

| | | |
|---------------------------------|--------|----------|
| Fuel Tank, total capacity | 242 L | 64 gal |
| Cooling System | 27.8 L | 7.3 gal |
| Engine Oil w/ Filter | 11.6 L | 3.1 gal |
| Eccentric Weight Housings | 26 L | 6.9 gal |
| Axle and Final Drives | 18 L | 4.8 gal |
| Hydraulic Tank (service refill) | 50 L | 13.2 gal |



CS68B Vibratory Soil Compactor

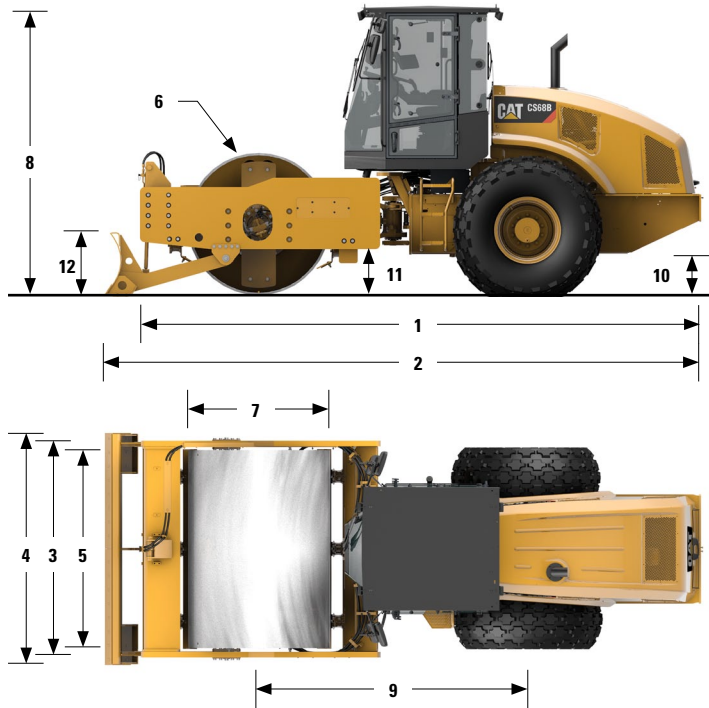

Dimensions

| | | |
|---|---------|----------|
| 1 Overall Length | 6.05 m | 19.8 ft |
| 2 Overall Length w/ Optional Leveling Blade | 6.55 m | 21.5 ft |
| 3 Overall Width | 2.33 m | 7.64 ft |
| 4 Overall Width w/ Optional Leveling Blade | 2.50 m | 8.25 ft |
| 5 Drum Width | 2134 mm | 84 in |
| 6 Drum Shell Thickness | 30 mm | 1.18 in |
| 7 Drum Diameter | 1434 mm | 56.5 in |
| 8 Overall Height | 3.11 m | 10.2 ft |
| 9 Wheelbase | 2.9 m | 9.5 ft |
| 10 Ground Clearance | 437 mm | 17.2 in |
| 11 Curb Clearance | 489 mm | 19.3 in |
| 12 Optional Leveling Blade Height | 688 mm | 27.1 in |
| Inside Turning Radius | 3.68 m | 12.07 ft |
| Hitch Articulation Angle | 34° | |
| Hitch Oscillation Angle | 15° | |
| Optional Leveling Blade Height | 688 mm | 27.1 in |

STANDARD EQUIPMENT *Varies by market- contact your Dealer for specifics.*

ELECTRICAL

- 24 volt Electrical System
- 100 ampere Alternator
- 750 Cold-cranking Amps Battery Capacity

OPERATOR ENVIRONMENT

- ROPS/FOPS Cab with Climate Control (Heat, Air Conditioning)
- Cloth Adjustable Pivoting Seat with Integrated Console and LCD Display, Seat Belt
- Multifunction LCD Display with gauges and/or audible warning alarm for: *Hydraulic oil temperature, Engine oil pressure, Engine coolant temperature, Alternator charge, Fuel level, Service hour meter, Engine RPM, Ground speed, Vibe frequency, Fuel rate, Air filter constriction, Engine load and Optional Cat Compaction Control*
- Adjustable Tilting Steering Column with Integrated Cup Holders
- 12-volt Power Outlet
- Floor Mat
- Interior Rear View Mirror
- Horn, Backup Alarm
- Radio-ready

POWER TRAIN

- Cat® C4.4 Diesel Engine
- Air Cleaner, Dual Element
- Three-speed Throttle Switch w/ Eco-mode, Automatic Speed Control
- Dual Propel Pumps; One for Drum Drive, One for Rear Axle
- Fuel Filter, Water Separator, Electronic Priming Pump, Water Indicator
- Tilting Radiator/Hydraulic Oil Cooler
- Dual Braking System
- Two-speed Hydrostatic Transmission

VIBRATORY SYSTEM

- Smooth Drum
- Dual Amplitude, Single Frequency
- Dual Pod-Style Eccentric Weight Housings
- Auto-vibe Function
- Front Adjustable Steel Scraper

OTHER

- Hydraulic Oil Level Sight Gauge
- Radiator Coolant Level Sight Gauge
- Cat® ToughGuard™ Hose
- S-O-SSM Sampling Valves, Engine Oil and Hydraulic Oil

OPTIONAL EQUIPMENT

- Padfoot Shell Kit
- Leveling Blade
- Variable Vibration Frequency
- Beacon, Rotating
- Polyurethane Drum Scrapers
- Steel Rear-side Drum Scraper
- Bio-oil Factory Fill
- Sun Visor
- Deluxe High-back Air-ride Pivoting Seat
- Cat Compaction Control, Machine Drive Power or CMV
- SBAS GNSS Mapping for Cat Compaction Control (RTK available)
- Upgraded Halogen Light Package
- Cab Internal Rear View Mirrors
- Cab Internal Roll-down Sun Screen
- Product Link
- Additional Rear View Mirrors

For more complete information on Cat products, dealer services, and industry solutions, visit us on the web at www.cat.com

QEHQ1560-02 (03-12)

© 2012 Caterpillar
All Rights Reserved
Printed in U.S.A.

Materials and specifications are subject to change without notice. Featured machines in photos may include additional equipment. See your Cat dealer for available options.

CAT, CATERPILLAR, SAFETY.CAT.COM, their respective logos, "Caterpillar Yellow" and the "Power Edge" trade dress, as well as corporate and product identity used herein, are trademarks of Caterpillar and may not be used without permission.

