



Cat[®] CS64B

SMOOTH DRUM VIBRATORY SOIL COMPACTOR

FEATURES:

The Cat[®] CS64B features a smooth drum and is ideally suited for granular soil applications:

- **Comfortable and ergonomic operator station** features pivoting seat with integrated multifunction LCD display and control console, outstanding visibility to the front and rear of machine, low sound levels and vibration for greater operator comfort and productivity.
- **World-class propel system** built around the exclusive Cat dual pump propel system, two pumps provide separate dedicated flow to drum drive motor and rear axle motor for exceptional gradeability and traction in forward and reverse. New electronic propel control enables more precise machine control.
- **Virtually maintenance free** due to maintenance-free hitch bearings and extended maintenance intervals for vibratory system and hydraulic system, providing more uptime and lower maintenance costs.
- **Enhanced compaction performance** due to more weight at the drum and greater amplitude. Automated propel and vibratory system functions make it easy to ensure consistent, high quality.
- **Optional Cat[®] Compaction Control** helps the operator determine when compaction has been completed to specification for greater productivity and uniform compaction quality.

Specifications

Engine - Power Train

Engine Model	Cat [®] C4.4 ACERT™	
Emission Standards	US EPA Tier 4 Final EU Stage IV	
Gross Power ISO 14396	98 kW	131 hp
Displacement	4.4 L	268.5 in ³
Stroke	127 mm	5 in
Bore	105 mm	4.1 in
Max. Travel Speed (Forward or Reverse)	11 km/h	6.8 mph

Weights

Operating Weight w/ ROPS/FOPS cab	12 055 kg	26,569 lb
w/ padfoot shell kit	13 465 kg	29,674 lb
Weight at Drum w/ ROPS/FOPS cab	7120 kg	15,690 lb
w/ padfoot shell kit	8525 kg	18,791 lb

Vibratory System Specifications

Frequency		
Standard	30.5 Hz	1830 vpm
During Eco-mode Operation	27.7 Hz	1664 vpm
Optional Variable Frequency	23.3-30.5 Hz	1400-1830 vpm
Nominal Amplitude @30.5 Hz (1830 vpm)		
High	1.9 mm	0.075 in
Low	0.95 mm	0.037 in
Centrifugal Force @ 30.5 Hz (1830 vpm)		
Maximum	234 kN	52,600 lb
Minimum	133 kN	29,900 lb
Static Linear Load		
w/ ROPS/FOPS Cab	33.4 kg/cm	186.8 lbs/in

Service Refill Capacities

Fuel Tank, total capacity	242 L	64 gal
Diesel Exhaust Fluid refill capacity	19 L	5 gal
Cooling System	27.4 L	7.2 gal
Engine Oil w/ Filter	8.8 L	2.3 gal
Eccentric Weight Housings	26 L	6.9 gal
Axle and Final Drives	18 L	4.8 gal
Hydraulic Tank (service refill)	50 L	13.2 gal



CS64B Vibratory Soil Compactor

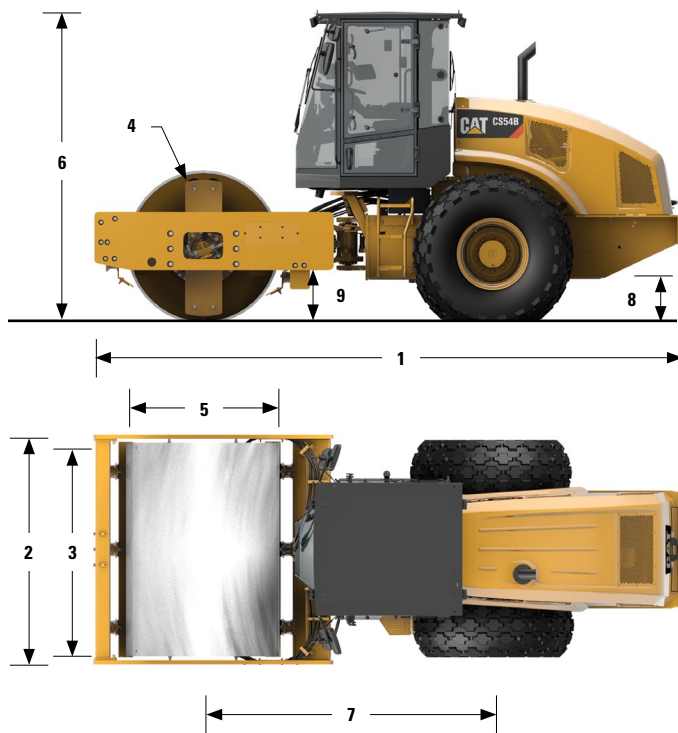

Dimensions

1 Overall Length	5.85 m	19.21 ft
2 Overall Width	2.33 m	7.64 ft
3 Drum Width	2134 mm	84 in
4 Drum Shell Thickness	25 mm	1 in
5 Drum Diameter	1534 mm	60.4 in
6 Overall Height	3.11 m	10.2 ft
7 Wheelbase	2.9 m	9.5 ft
8 Ground Clearance	442 mm	17.4 in
9 Curb Clearance	491 mm	19.3 in
Inside Turning Radius	3.68 m	12.07 ft
Hitch Articulation Angle	34°	
Hitch Oscillation Angle	15°	

STANDARD EQUIPMENT Varies by market- contact your Dealer for specifics.

ELECTRICAL

- 24 volt Electrical System
- 100 ampere Alternator
- 750 Cold-cranking Amps Battery Capacity

OPERATOR ENVIRONMENT

- ROPS/FOPS Cab w/ Climate Control (Heat, Air Conditioning), Floor Mat
- Cloth Adjustable Pivoting Seat with Integrated Console and LCD Display, Seat Belt
- Multifunction LCD Display with gauges and/or audible warning alarm for: *Hydraulic oil temperature, Engine oil pressure, Engine coolant temperature, Alternator charge, Fuel level, Service hour meter, Engine RPM, Ground speed, Vibe frequency, Fuel rate, Air filter constriction, Engine load and Optional Cat Compaction Control*
- Adjustable Tilting Steering Column with Integrated Cup Holders
- 12-volt Power Outlet
- Interior Rear View Mirror
- Horn, Backup Alarm
- Radio-ready

POWER TRAIN

- Cat® C4.4 Diesel Engine
- Air Cleaner, Dual Element
- Three-speed Throttle Switch w/ Eco-mode, Automatic Speed Control
- Dual Propel Pumps; One for Drum Drive, One for Rear Axle
- Fuel Filter, Water Separator, Electronic Priming Pump, Water Indicator
- Tilting Radiator/Hydraulic Oil Cooler
- Dual Braking System
- Two-speed Hydrostatic Transmission

VIBRATORY SYSTEM

- Smooth Drum
- Dual Amplitude, Single Frequency
- Dual Pod-Style Eccentric Weight Housings
- Auto-vibe Function
- Front Adjustable Steel Scraper

OTHER

- Hydraulic Oil Level Sight Gauge
- Radiator Coolant Level Sight Gauge
- Cat® ToughGuard™ Hose
- S-O-SSM Sampling Valves, Engine Oil and Hydraulic Oil

OPTIONAL EQUIPMENT

- Padfoot Shell Kit
- Variable Vibration Frequency
- Beacon, Rotating
- Polyurethane Drum Scrapers
- Steel Rear-side Drum Scraper
- Bio-oil Factory Fill
- Sun Visor
- Deluxe High-back Air-ride Pivoting Seat (with Cab only)
- Cat Compaction Control, Machine Drive Power or CMV or Both
- SBAS GNSS Mapping for Cat Compaction Control (RTK available)
- Upgraded Halogen Light Package
- Cab Internal Rear View Mirrors
- Cab Internal Roll-down Sun Screen
- Product Link
- Additional Rear View Mirrors
- Italian Road Homologation (IRH)
- Recording Module
- Fuel Door

For more complete information on Cat products, dealer services, and industry solutions, visit us on the web at www.cat.com

QEHQ1635-01 (06-15)

© 2015 Caterpillar
All Rights Reserved
Printed in U.S.A.

Weights and dimensions listed are approximate. Materials and specifications are subject to change without notice. Featured machines in photos may include additional equipment. See your Cat dealer for available options.

CAT, CATERPILLAR, BUILT FOR IT, their respective logos, "Caterpillar Yellow" and the "Power Edge" trade dress, as well as corporate and product identity used herein, are trademarks of Caterpillar and may not be used without permission.

