



# Cat® CS56B

## SMOOTH DRUM VIBRATORY SOIL COMPACTOR

### FEATURES:

The Cat® CS56B features a smooth drum and is ideally suited for granular soil applications:

- **Comfortable and ergonomic operator station** features pivoting seat with integrated multifunction LCD display and control console, outstanding visibility to the front and rear of machine, low sound levels and vibration for greater operator comfort and productivity.
- **World-class propel system** built around the exclusive Cat dual pump propel system, two pumps provide separate dedicated flow to drum drive motor and rear axle motor for exceptional gradeability and traction in forward and reverse. New electronic propel control enables more precise machine control.
- **Virtually maintenance free** due to maintenance-free hitch bearings and extended maintenance intervals for vibratory system and hydraulic system, providing more uptime and lower maintenance costs.
- **Enhanced compaction performance** due to more weight at the drum and greater amplitude. Automated propel and vibratory system functions make it easy to ensure consistent, high quality.
- **Optional Cat® Compaction Control** helps the operator determine when compaction has been completed to specification for greater productivity and uniform compaction quality.

## Specifications

### Engine - Power Train

Engine Model	Cat® C4.4 ACERT™	
Emission Standards	US EPA Tier 4 Final EU Stage IV	
Gross Power ISO 14396	117 kW	157 hp
Displacement	4.4 L	268.5 in³
Stroke	127 mm	5 in
Bore	105 mm	4.1 in
Max. Travel Speed (Forward or Reverse)	11.4 km/h	7 mph

### Weights

Operating Weight w/ ROPS/FOPS canopy	11 290 kg	24,887 lb
w/ padfoot shell kit	12 700 kg	27,990 lb
w/ leveling blade	11 915 kg	26,260 lb
w/ padfoot shell kit and leveling blade	13 325 kg	29,363 lb
Operating Weight w/ ROPS/FOPS cab	11 500 kg	25,346 lb
w/ padfoot shell kit	12 900 kg	28,433 lb
w/ leveling blade	12 115 kg	26,703 lb
w/ padfoot shell kit and leveling blade	13 525 kg	29,806 lb
Weight at Drum w/ ROPS/FOPS canopy	6255 kg	13,788 lb
w/ padfoot shell kit	7660 kg	16,887 lb
w/ leveling blade	7145 kg	15,749 lb
w/ padfoot shell kit and leveling blade	8550 kg	18,848 lb
Weight at Drum w/ ROPS/FOPS cab	6350 kg	13,990 lb
w/ padfoot shell kit	7755 kg	17,092 lb
w/ leveling blade	7240 kg	15,952 lb
w/ padfoot shell kit and leveling blade	8645 kg	19,053 lb

### Vibratory System Specifications

Frequency		
Standard	30.5 Hz	1830 vpm
During Eco-mode Operation	27.7 Hz	1664 vpm
Optional Variable Frequency	23.3-30.5 Hz	1400-1830 vpm
Nominal Amplitude @30.5 Hz (1830 vpm)		
High	2.1 mm	0.083 in
Low	0.98 mm	0.039 in
Centrifugal Force @ 30.5 Hz (1830 vpm)		
Maximum	301 kN	67,600 lb
Minimum	141 kN	31,670 lb
Static Linear Load		
w/ ROPS/FOPS	29.3 kg/cm	164.1 lbs/in
w/ ROPS/FOPS Cab	29.8 kg/cm	166.5 lbs/in

### Service Refill Capacities

Fuel Tank, total capacity	242 L	64 gal
Diesel Exhaust Fluid refill capacity	19 L	5 gal
Cooling System	27.8 L	7.3 gal
Engine Oil w/ Filter	11.6 L	3.1 gal
Eccentric Weight Housings	26 L	6.9 gal
Axle and Final Drives	18 L	4.8 gal
Hydraulic Tank (service refill)	50 L	13.2 gal



# CS56B Vibratory Soil Compactor

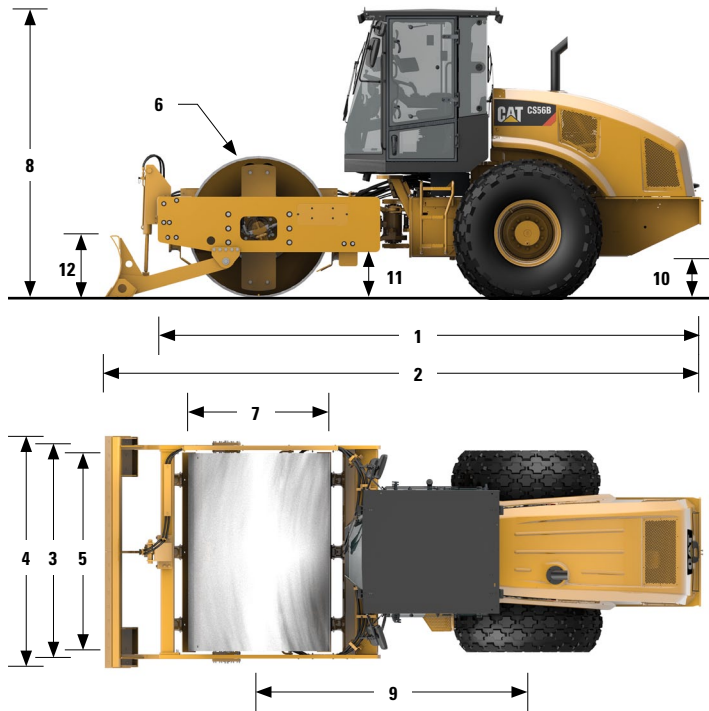

## Dimensions

<b>1</b> Overall Length	5.86 m	19.2 ft
<b>2</b> Overall Length w/ optional Leveling Blade	6.4 m	20.9 ft
<b>3</b> Overall Width	2.30 m	7.53 ft
<b>4</b> Overall Width w/ optional Leveling Blade	2.50 m	8.25 ft
<b>5</b> Drum Width	2134 mm	84 in
<b>6</b> Drum Shell Thickness	30 mm	1.18 in
<b>7</b> Drum Diameter	1534 mm	60.4 in
<b>8</b> Overall Height		
-Cab	3.11 m	10.2 ft
-ROPS/FOPS	3.08 m	10.1 ft
<b>9</b> Wheelbase	2.9 m	9.5 ft
<b>10</b> Ground Clearance	442 mm	17.4 in
<b>11</b> Curb Clearance	494 mm	19.3 in
<b>12</b> Optional Leveling Blade Height	688 mm	27.1 in
Inside Turning Radius	3.68 m	12.07 ft
Hitch Articulation Angle	34°	
Hitch Oscillation Angle	15°	

## STANDARD EQUIPMENT *Varies by market- contact your Dealer for specifics.*

### ELECTRICAL

- 24 volt Electrical System
- 100 ampere Alternator
- 750 Cold-cranking Amps Battery Capacity

### OPERATOR ENVIRONMENT

- ROPS/FOPS
- Vinyl Adjustable Pivoting Seat with Integrated Console, Seat Belt
- Multifunction LCD Display with gauges and/or audible warning alarm for: *Hydraulic oil temperature, Engine oil pressure, Engine coolant temperature, Alternator charge, Fuel level, Service hour meter, Engine RPM, Ground speed, Vibe frequency, Fuel rate, Air filter constriction, Engine load and Optional Cat Compaction Control*
- Platform Handrails/Guardrails
- Adjustable Tilting Steering Column with Integrated Cup Holders
- Lockable Vandalism Guard on LCD Display
- 12-volt Power Outlet
- Floor Mat
- Interior Rear View Mirror
- Horn, Backup Alarm

### POWER TRAIN

- Cat® C4.4 Diesel Engine
- Three-speed Throttle Switch w/ Eco-mode, Automatic Speed Control
- Dual Propel Pumps; One for Drum Drive, One for Rear Axle
- Fuel Filter, Water Separator, Electronic Priming Pump, Water Indicator
- Tilting Radiator/Hydraulic Oil Cooler
- Dual Braking System
- Two-speed Hydrostatic Transmission

### VIBRATORY SYSTEM

- Smooth Drum
- Dual Amplitude, Single Frequency
- Pod-Style Eccentric Weight System
- Auto-vibe Function
- Front Adjustable Steel Scraper

### OTHER

- Hydraulic Oil Level Sight Gauge
- Radiator Coolant Level Sight Gauge
- Cat® ToughGuard™ Hose
- S-O-S<sup>SM</sup> Sampling Valves, Engine Oil and Hydraulic Oil

## OPTIONAL EQUIPMENT

- ROPS/FOPS Cab with Climate Control
- Padfoot Shell Kit
- Leveling Blade
- Variable Vibration Frequency
- Beacon, Rotating
- Polyurethane Drum Scrapers
- Steel Rear-side Drum Scraper
- Bio-oil Factory Fill
- High Ambient Temperature Oil Factory Fill
- Sun Visor
- Deluxe High-back Air-ride Pivoting Seat (with Cab only)
- Cat Compaction Control, Machine Drive Power or CMV or Both
- SBAS GNSS Mapping for Cat Compaction Control (RTK available)
- Upgraded Halogen Light Package
- Cab Internal Rear View Mirrors
- Cab Internal Roll-down Sun Screen
- Product Link
- Additional Rear View Mirrors

For more complete information on Cat products, dealer services, and industry solutions, visit us on the web at [www.cat.com](http://www.cat.com)

QEHQ1558-02 (06-15)

© 2015 Caterpillar  
All Rights Reserved  
Printed in U.S.A.

Materials and specifications are subject to change without notice. Featured machines in photos may include additional equipment. See your Cat dealer for available options.

CAT, CATERPILLAR, BUILT FOR IT, their respective logos, "Caterpillar Yellow" and the "Power Edge" trade dress, as well as corporate and product identity used herein, are trademarks of Caterpillar and may not be used without permission.

