

TECHNICAL DATA

SOIL COMPACTOR

BC 473 EB-4

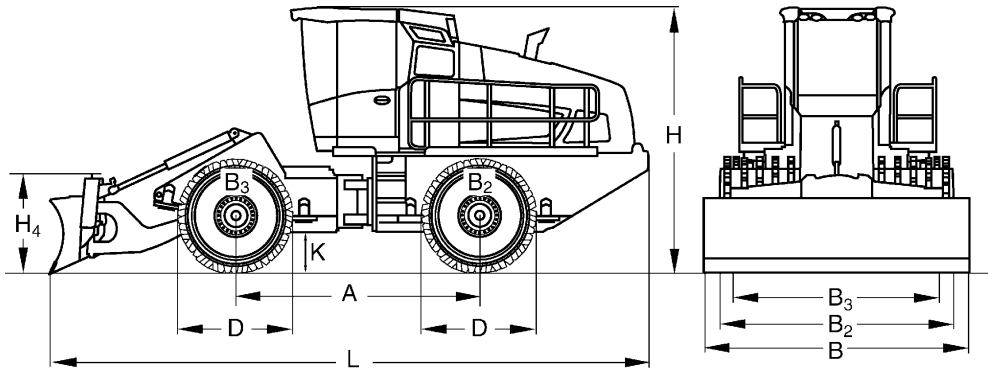



Dimensions in mm

	A	B	B2	B3	D	H	H4	K	L
BC 473 EB-4	3500	3600	3560	3335	1580	3820	1027	600	8990

Shipping dimensions in m3

BC 473 EB-4	123,630
--------------------	---------

Technical Data

BOMAG BC 473 EB-4

Weights

Grossweight	kg	26.800
Operating weight CECE	kg	26.000
Axle load, front CECE	kg	12.750
Axle load, rear CECE	kg	13.250

Driving Characteristics

Speed (1), forward	km/h	0- 4,5
Speed (1), reverse	km/h	0- 4,5
Speed (2), forward	km/h	0- 12,0
Speed (2), reverse	km/h	0- 12,0
Max. gradeability (dep. on soil con.)	%	100
Max. pushing force	kN	281

Drive

Engine manufacturer		Merc. Benz/MTU
Type		OM 936 LA
Emission stage		Stage IV / TIER4f
Exhaust gas aftertreatment		SCR
Cooling		Liquid
Number of cylinders		6
Performance ISO 9249	kW	210,0
Performance SAE J 1349	hp	281,0
Speed	min-1	2.200
Travel system		hydrost.
Operating voltage	V	24

Compaction Wheels

Width, front	mm	1.125
Width, rear	mm	1.125
Outer diameter (front)	mm	1.580
Outer diameter (rear)	mm	1.580
Number of teeth/cutters, front		60
Number of teeth/cutters, rear		60
Compaction coverage per side	mm	1.238

Brakes

Service brake		hydrost.
Parking brake		hydromec.

Steering

Steering system		oscil.artic.
Steering method		hydraulic
Steering angle +/-	grad	35
Oscillating angle +/-	grad	15
Track radius, inner	mm	3.762

Dozer Blade

Height adjustment over ground level	mm	1.200
Height adjustment below ground level	mm	120

Capacities

Fuel	l	375,0
Hydraulic oil	l	260,0
AdBlue	l	40,0

Technical modifications reserved. Machines may be shown with options.

Standard Equipment

Optional Equipment

- Central lubrication system
- CD-Radio
- Pre start cabin heating
- Rotary beacon
- Fire extinguisher
- Special painting
- Environmentally compliant hydraulic oil
- Electrical anti-theft system with numerical code
- Protective ventilation system (Pre-installation)
- Tool kit
- Protective grille for cabin
- TELEMATIC POWER
- Climatronic
- Tachograph
- LED Working head lights
- Cold start device (115V)

