

TECHNICAL DATA

SOIL COMPACTOR

BC 462 EB

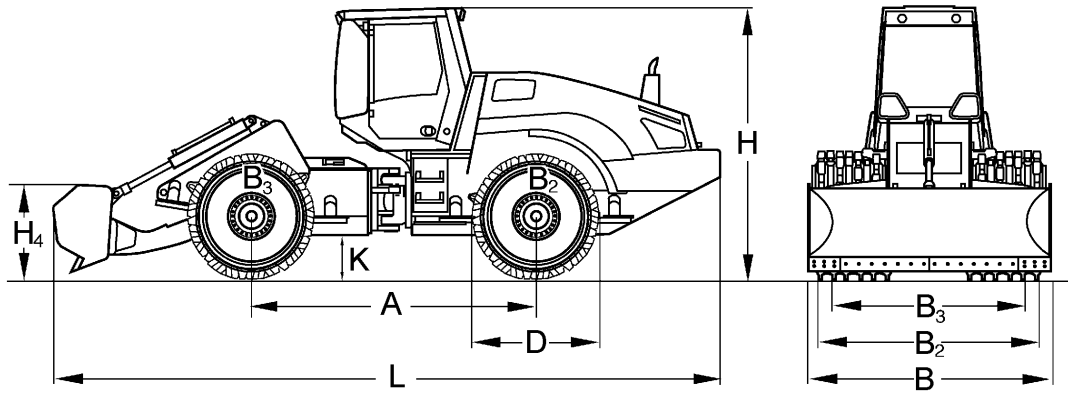



Dimensions in mm

	A	B	B2	B3	D	H	H4	K	L
BC 462 EB	3500	2998	2660	2885	1580	3390	1050	600	8230

Shipping dimensions in m3

BC 462 EB

83,643

Technical Data

BOMAG BC 462 EB

Weights

Operating weight CECE	kg	21.300
Axle load, front CECE	kg	10.300
Axle load, rear CECE	kg	11.000

Dimensions

Rear overhang	mm	1.460
---------------------	----	-------

Driving Characteristics

Speed (1), forward	km/h	0- 4,5
Speed (1), reverse	km/h	0- 4,5
Speed (2), forward	km/h	0- 14,0
Speed (2), reverse	km/h	0- 14,0
Max. gradeability (dep. on soil con.)	%	100

Drive

Engine manufacturer		Deutz
Type		TCD 2013 L06 2V
Emission stage		Stage IIIa / TIER3
Cooling		Liquid
Number of cylinders		6
Performance ISO 9249	kW	190,0
Performance SAE J 1349	hp	254,0
Speed	min-1	2.300
Travel system		hydrost.
Number of travel motors		4
Operating voltage	V	12

Compaction Wheels

Width, front	mm	900
Width, rear	mm	900
Outer diameter (front)	mm	1.580
Outer diameter (rear)	mm	1.580
Number of teeth/cutters, front		40
Number of teeth/cutters, rear		40
Compaction coverage per side	mm	1.013

Brakes

Service brake		hydrost.
Parking brake		hydromec.
Emergency brake		hydromec.

Steering

Steering system		oscil.artic.
Steering method		hydraulic
Steering angle +/-	grad	35
Oscillating angle +/-	grad	15
Track radius, inner	mm	4.116

Dozer Blade

Height adjustment over ground level	mm	1.200
Height adjustment below ground level	mm	120

Capacities

Fuel	l	375,0
Engine oil	l	27,5
Hydraulic oil	l	280,0

Technical modifications reserved. Machines may be shown with options.

Standard Equipment

Optional Equipment

- ROPS/FOPS
- Noise insulated cab with heating or with automatic heating ? air condition
- Sun roof
- Reversible fan
- Differential lock, rear
- Dozer blade with tilting mechanism
- Central lubrication system
- Adjustable comfortable seat
- Cabin ventilation with activated carbon filter and overpressure
- CD-Radio
- Pre start cabin heating
- Rotary beacon
- Fire extinguisher
- Special painting
- Environmentally compliant hydraulic oil
- Electrical anti-theft system with numerical code
- Engine rpm preselection / Decelerator pedal
- Tool kit
- Protective grille for cabin

