

TECHNICAL DATA

ASPHALT MANAGER 2

BW 151 AD-5 AM, BW 161 AD-5 AM

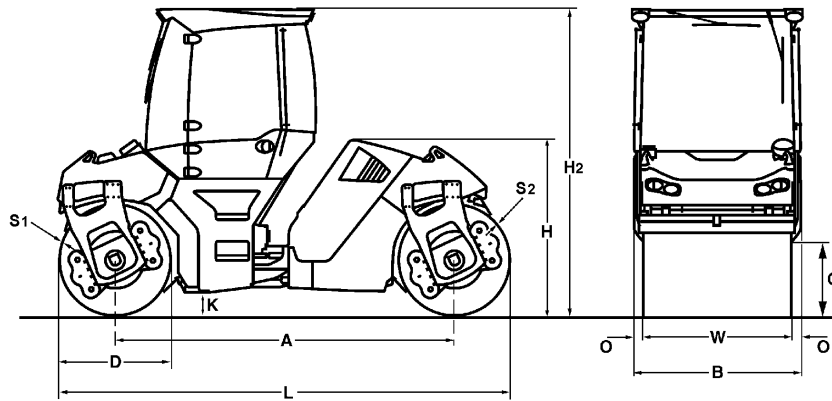



Dimensions in mm

	A	B	C	D	H	H2	K	L	O	S1	S2	W
BW 151 AD-5 AM	3300	1844	730	1100	2240	3000	250	4400	82	16	16	1680
BW 161 AD-5 AM	3620	1836	670	1220	2315	3050	250	4840	78	19	17	1680

Shipping dimensions in m3

BW 151 AD-5 AM
 BW 161 AD-5 AM

without ROPS

18,174
 20,572

with ROPS

24,341
 27,103

Machine type	Compaction output (m3/h) at recommended soil layer thicknesses		
	Gravel, sand	Mixed soil	Silt, clay
BW 151 AD-5 AM	150-300	110-230	75-180
BW 161 AD-5 AM	180-340	150-280	110-180

Machine type	Compaction output (t/h) at different asphalt layer thicknesses		
	2-4 cm	6-8 cm	10-14 cm
BW 151 AD-5 AM	50-90	100-180	150-210
BW 161 AD-5 AM	60-130	100-230	160-280

Technical Data**BOMAG
BW 151 AD-5 AM****BOMAG
BW 161 AD-5 AM****Weights**

Operating weight CECE w. ROPS-cabin	kg	7.900	10.200
Grossweight	kg	9.000	11.500
Axle load, front CECE	kg	4.050	5.300
Axle load, rear CECE	kg	3.850	4.900
Static linear load, front CECE	kg/cm	24,1	31,6
Static linear load, rear CECE	kg/cm	22,9	29,2

Dimensions

Track radius, inner	mm	4.390	4.900
Length (without towing hitch)	mm	4.400	4.840

Driving Characteristics

Max. travel speed	km/h	0- 12,0	0- 12,0
Max. gradeability without/with vibr.	%	40/30	40/30

Drive

Engine manufacturer		Kubota	Deutz
Type		V3307 CR-T	TCD 3.6 L4
Emission stage		Stage IIIb / TIER4f	Stage IV / TIER4f
Exhaust gas aftertreatment		DOC+DPF	DOC+SCR
Cooling		water	Liquid
Number of cylinders		4	4
Performance ISO 14396	kW	55,4	95,0
Performance SAE J 1995	hp	74,3	127,0
Speed	min-1	2.400	2.300
Electric equipment	V	12	12

Brakes

Service brake		hydrost.	hydrost.
Parking brake		multi disc	multi disc

Steering

Steering system		oscil.artic.	oscil.artic.
-----------------------	--	--------------	--------------

Exciter system

Vibrating drum		rear	rear
Autom. vibr. shut off		standard	standard
Frequency	Hz	46/45	46/45
Amplitude	mm	0,68/0,27	0,87/0,44
Centrifugal force	kN	75/30	97/51
Centrifugal force	t	7,6/3,1	9,9/5,2

Vario system

ASPHALT MANAGER		front	front
Frequency	Hz	46	46
Amplitude directed		autom./variable	autom./variable
Amplitude	mm	0- 0,89	0- 0,92
Centifugal force	kN	142	152
Centifugal force	t	14,5	15,5

Capacities

Fuel	l	125,0	145,0
Water	l	600,0	750,0

Technical modifications reserved. Machines may be shown with options.

Standard Equipment

- ASPHALT MANAGER 2
- Highly wear resistant drum
- Oscillation mode
- 2 amplitudes / 2 frequencies rear
- ECOMODE
- Autom. vibration operation
- Individual vibration control
- Swivel seat with integrated electronic steering wheel
- Emergency stop button
- V-belt protection
- Pressure sprinkling system with 2 pumps
- Indicator and hazard lights
- Back-up alarm
- Battery disconnect switch
- Compartments for documents and tools
- BOMAG OPERATION PANEL (BOP)
- EVIB-Control panel
- Asphalt temperature display

Optional Equipment

- ROPS cabin with seat belts
 - + heating, Ventilation
 - + 4 Working head lights
- ROPS cabin with air conditioning
- Rotary beacon
- Crab-walk to both sides (170mm)
- 2 LED-lights for cabin roof (flatbeam)
- Edge cutter
- Special painting
- Environmentally compliant hydraulic oil
- Radio/Radio preparation
- Precision spreader laterally slidable
- Precision spreader
- Printer for ASPHALT MANAGER 2
- Lighting for drum edge front and rear
- Seat heating
- Approval by the German TÜV
- BOMAG TELEMATIC POWER
- Outside mirrors
- BCM-Documentation system

