

Volvo P7820C_{ABG}, P8820C_{ABG} in detail

SPECIFICATIONS			
		P7820C ABG	P8820C ABG
Engine (diesel)			
Manufacturer		Volvo	Volvo
Model		D7E	D7E
Output	kW	170	182
	hp	231	247
at engine speed	r/min	1 800	2 000
Coolant		Liquid	Liquid
Fuel tank capacity	l	240	240
Exhaust emission		Stage IIIA / Tier 3	Stage IIIA / Tier 3
Paving			
Output (theoretical)*	t/h	900	1 100
Mat thickness (max)	mm	300	300
Speed			
Paving (max)	m/min	20	20
Transport (max)	km/h	3.6	3.6
Undercarriage			
Length	mm	3 000	3 120
Width (track plates)	mm	300	325
Conveyor			
Hopper capacity	t	13.5	14
Number of conveyors		2	2
Conveyor speed (max)	m/min	24	24
Auger			
Number of augers		2	2
Speed (max)	1/min	95	100
Diameter	mm	360	360
Electrics			
Battery voltage	V	24	24
Dimensions			
Length with Vario Screed (Walkway up)	mm	6 137	6 427
Length with Fixed Screed	mm	5 929	6 237
Width	mm	2 548	2 548
Height	mm	3 785	3 945
Height (transport)	mm	2 917	3 075
Weight**			
Tractor unit	kg	15 600	17 700

1 The actual paving output depends upon the mat thickness, the paving width and paving speed and will vary according to paving conditions prevailing on your jobsite.

Please approach us and we will be pleased to assist you in calculating the paving output for your particular paving project.

2 Approximate weight without screed / with standard hopper / fuel tank half full / towing arms separated / 75kg driver

Sound Level			
		P7820C ABG	P8820C ABG
Sound Pressure Level at Driver's Ear, acc. to ISO 11201			
LpA	dB(A)	83 (with all screeds)	84 (with all screeds)
Guaranteed Sound Power Level, acc. to Directive 2000/14/EC			
LwA	dB(A)	105 (with all screeds)	106 (with all screeds)

Specifications

Ca. operating weights* of screeds in kg (lb)

At working width	P7820C, P8820C											P8820C		
	2.5 m	4 m	5 m	6 m	6.5 m	7 m	7.5 m	8 m	8.5 m	9 m	10 m	11 m	12 m	13 m
VB 78 ETC			3 600		5 222		5 782	6 342		6 903				
VB 78 GTC			3 680		5 342		5 912	6 502		7 073				
VDTV 78 ETC			3 720		5 442		6 032	6 662		7 253				
VDTV 78 GTC			3 800		5 562		6 172	6 822		7 433				
VB 79 ETC			3 730		5 352		5 912	6 472		7 033				
VDTV 79 ETC			4 100		5 822		6 412	7 042		7 633				
VB 88 ETC				3 820			5 542		6 102	6 662	7 223			
VB 88 GTC				3 900			5 662		6 232	6 822	7 393			
VDTV 88 ETC				4 450			6 272		6 862	7 492				
VDTV 88 GTC				4 520			6 382		6 992	7 642				
VB 89 ETC				4 200			5 922		6 482	7 042				
VDTV 89 ETC				4 570			6 392		6 982	7 612				
MB 122	1 800	3 065		4 752		5 595	6 017	6 439		7 282	8 126	8 969	9 813	10 656
VDT 121	2 100			5 052			6 317			7 582			10 113	10 956

* Including auger extensions, channel plates etc.

DIMENSIONS

		P7820C	P8820C
A	mm	6 388	6 678
B	mm	3 000	3 120
C	mm	415	485
D	mm	548	548
E	mm	1 615	1 625
F	mm	360±60	360±60
G	mm	2 170	2 170
H	mm	3 793	3 950
I	mm	1 373	1 397
J	mm	608	630
K	mm	525	528
L	mm	435	438
M	mm	13°	13°
N	mm	160	160
O	mm	438	433
P	mm	1 614	1 771
Q	up	mm 3 785	mm 3 942
	down	mm 2 917	mm 3 075
R	open	mm 3 252	mm 3 337
	closed	mm 2 476	mm 2 560
S	mm	3 168	3 253
T	mm	2 495	2 495
U	mm	320	320
V	mm	2 500/ 3 000	2 500/ 3 000
W	mm	5 000/ 6 000	5 000/ 6 000
X	mm	300	325
Y	mm	2 269	2 335
Z	mm	300	770

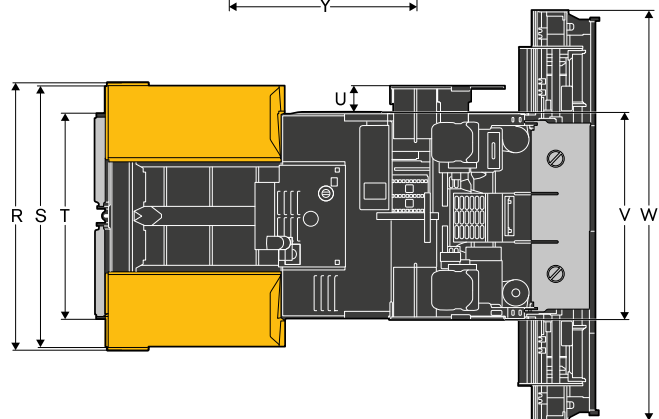
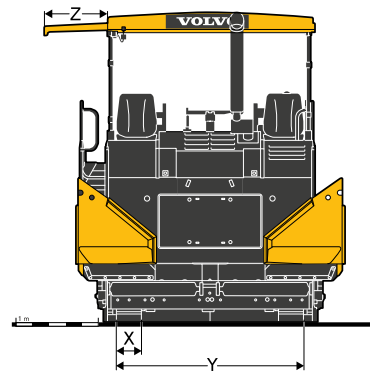
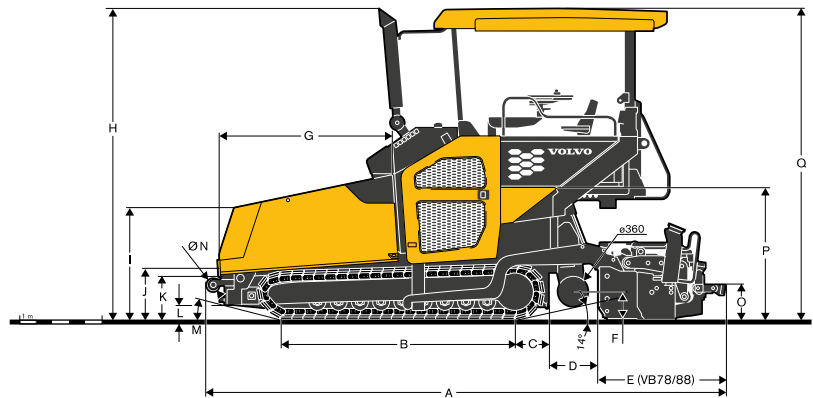

Equipment

STANDARD EQUIPMENT		
	P7820C ABG	P8820C ABG
Engine		
Volvo Diesel engine, Stage IIIA / Tier 3	•	•
Drive		
Electronic drive control	•	•
Lifetime lubricated crawler track rollers	•	•
Forged and hardened crawler track links	•	•
Automatic track tensioner	•	•
Material Management		
Large truck buffer rollers with 160 mm Ø	•	•
Four individual hydrostatic drives for conveyors and augers	•	•
Hydraulic auger height adjustment	•	•
Reversible direction of auger rotation	•	•
Proportional auger speed control	•	•
Electronics		
Electronic Paver Management (EPM 2)	•	•
Smart power	•	•
Settings Manager	•	•
Service Interval Manager	•	•
Adjustable and revolving control unit	•	•
Electric switch cabinet	•	•
Battery master switch	•	•
Two external control panels for the paving screed	•	•
Structure		
Two seats, laterally extendable	•	•
Anti-vandalism kit	•	•
Screed		
Split towing arms	•	•
Hydraulics for Vario screeds with tamper and vibration	•	—
Hydraulics for Vario screeds with double tamper and vibration & man. adjust. screeds	—	•
Screed lock	•	•
Lights		
Four working lights	•	•
Driver's compartment lighting	•	•
Environmental		
Sound insulation	•	•

OPTIONAL EQUIPMENT		
	P7820C ABG	P8820C ABG
Material Management		
Individual operating hopper wings	•	•
Hydraulically operated front apron	•	•
Reversible conveyor	•	•
Proportional Ultrasonic Sensor auger control according to material requirements	•	•
Central lubrication	•	•
Electronics		
Levelling systems	•	•
Auxiliary control panel	•	•
Additional sockets 230V	•	•
Structure		
Deluxe seats with heating	•	•
GRP (Glass-fibre reinforced plastic) all-weather roof	•	•
Front windscreen (only in conjunction with all-weather roof)	•	•
Tarpaulin for sides	•	•
Special paintwork (according to RAL colour code, excluding metallic paintwork)	•	•
Screed		
Hydraulics for Vario screeds with double tamper and vibration & man. adjust. screeds	•	—
Screed anti-climbing lock	•	•
Screed tensioning device	•	•
Screed assist	•	•
Screed load device	•	•
Hydraulic height adjustment of extendable screeds	•	•
Lights		
Xenon working lights (only in conjunction with all-weather roof)	•	•
Two additional working lights (rear)	•	•
Auger lighting	•	•
Warning beacons	•	•
Environmental		
Extractor for bituminous fumes	•	•
Emulsions spraying system	•	•
Heavy-duty spray cleaning gun	•	•
Biodegradeable hydraulic oil	•	•

Not all products are available in all markets. Under our policy of continuous improvement, we reserve the right to change specifications and design without prior notice. The illustrations do not necessarily show the standard version of the machine.