

Volvo P6820D ABG, P7820D ABG in detail

		P6820D ABG	P7820D ABG
Engine (diesel)			
Manufacturer		Volvo	Volvo
Model		D6E GAE3	D7E GEE3
Output	kW	140	170
	hp	190	231
at engine speed	r/min	2 000	1 800
Coolant		Liquid	Liquid
Fuel tank capacity	l	250	250
Exhaust emission		EU Stage 3a / EPA Tier 3	EU Stage 3a / EPA Tier 3
Paving			
Output (theoretical)*	t/h	700	900
Mat thickness (max)	mm	300	300
Speed			
Paving (max)	m/min	20	20
Transport (max)	km/h	3.0	3.6
Undercarriage			
Length	mm	3 000	3 000
Width (track plates)	mm	300	300
Conveyor			
Hopper capacity	t	13.5	13.5
Number of conveyors		2	2
Conveyor speed (max)	m/min	23	23
Auger			
Speed (max)	1/min	95	95
Diameter	mm	360	360
Electrics			
Battery voltage	V	24	24
Dimensions			
Length with Vario Screed (Walkway up)	mm	6 120	6 120
Width	mm	2 548	2 548
Height	mm	3 785	3 785
Height (transport)	mm	2 934	2 934
Weight**			
Tractor unit	kg	14 200	14 650
Max. allowable gradeability***			
Tractor unit + screed	%	25	25

* The actual paving output depends upon the mat thickness, the paving width and paving speed and will vary according to paving conditions prevailing on your jobsite. Please approach us and we will be pleased to assist you in calculating the paving output for your particular paving project.

** All weights are approx. weights without options. Weight of tractor without screed, with standard hopper, with fuel tank half full, with towing arms separated, with push roller D=110 mm, and incl. 75 kg driver.

*** Applies to screed VB 78 2.5-5.0 m. When using extensions the max. allowable gradeability will be reduced.

Sound Level		P6820D ABG	P7820D ABG
Sound Pressure Level at Driver's Ear, acc. to ISO 11201			
LpA	dB(A)	82	83
Guaranteed Sound Power Level, acc. to Directive 200/14/EC			
LwA	dB(A)	105	105

Specifications

DIMENSIONS

		P6820D and P7820D
Unit		mm
A	Standard	6 120
	Soft Dock	6 244
B		3 000
C		268
D		275
E		265
F		360 ± 60
G		2 151
H		3 792
I		1 385
J		607
K		160
L		436
M		770
N		320
O		1 615
P		1 025
Q	up	3 785
	down	2 934
R	open	3 256
	closed	2 452
S		3 169
T		2 495
U		300
V		2 269
W		438
X		1 280
Y		2 500
Z		5 000

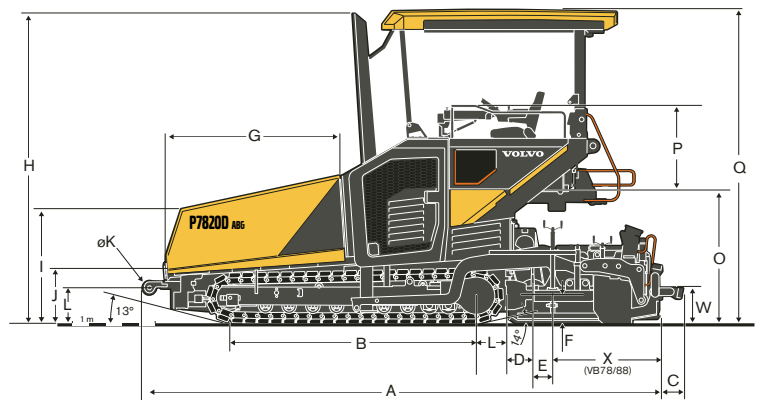
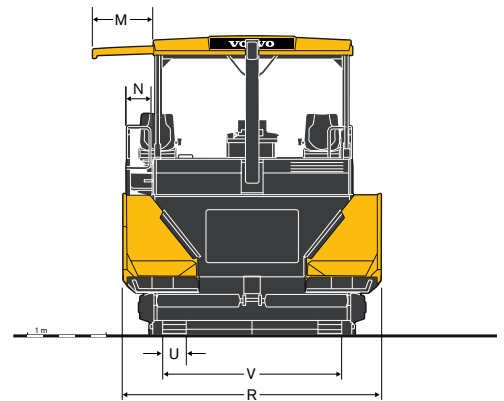
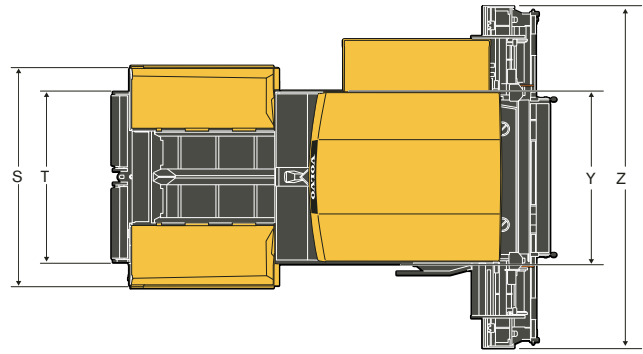

OPERATING WEIGHTS¹ OF SCREEDS IN KG

At working width	2.5 m	4 m	5 m	6 m	6.5 m	7 m	7.5 m	8 m	8.5 m	9 m	10 m	11 m
P6820D ABG												
VB 78 ETC	-	-	3 600	-	5 222	-	5 782	6 342	-	6 903	-	-
VDT-V 78 ETC	-	-	3 720	-	5 442	-	6 032	-	-	-	-	-
VB 79 ETC	-	-	3 730	-	5 352	-	5 912	6 472	-	7 033	-	-
VB 88 ETC	-	-	-	3 820	-	-	5 542	-	6 102	6 662	-	-
VDT-V 88 ETC	-	-	-	4 450	-	-	6 272	-	-	-	-	-
MB 122	1 800	3 065	-	4 752	-	5 595	6 017	6 439	-	7 282	8 126	-
P7820D ABG												
VB 78 ETC	-	-	3 600	-	5 222	-	5 782	6 342	-	6 903	-	-
VDT-V 78 ETC	-	-	3 720	-	5 442	-	6 032	6 662	-	7 253	-	-
VB 79 ETC	-	-	3 730	-	5 352	-	5 912	6 472	-	7 033	-	-
VDT-V 79 ETC	-	-	4 100	-	5 822	-	6 412	7 072	-	7 633	-	-
VB 88 ETC	-	-	-	3 820	-	-	5 542	-	6 102	6 662	7 223	-
VDT-V 88 ETC	-	-	-	4 450	-	-	6 272	-	6 862	7 492	-	-
VB 89 ETC	-	-	-	4 200	-	-	5 922	-	6 482	7 042	-	-
VDT-V 89 ETC	-	-	-	4 570	-	-	6 392	-	6 982	7 612	-	-
MB 122	1 800	3 065	-	4 752	-	5 595	6 017	6 439	-	7 282	8 126	8 969
VDT 121	2 100	-	-	5 052	-	-	6 317	-	-	7 582	-	-

¹ Including auger extensions, channel plates, end gates, towing arms rear, etc.

Equipment

STANDARD EQUIPMENT

	P6820D ABG	P7820D ABG
Engine		
Volvo Diesel engine, EU Stage 3a / EPA Tier 3	•	•
Drive		
Electronic drive control	•	•
Lifetime lubricated crawler track rollers	•	•
Forged and hardened crawler track links	•	•
Automatic track tensioner	•	•
Material Management		
Proportional conveyor sensors	•	•
Four individual hydrostatic drives for conveyors and augers	•	•
Reversible direction of auger rotation	•	•
Hydraulic auger height adjustment	•	•
Proportional ultrasonic sensor auger control	•	•
Electrics and electronics		
Electronic Paver Management (EPM 3)	•	•
ECO mode	•	•
Settings Manager	•	•
Service Interval Manager	•	•
Adjustable and revolving main control panel at operator platform	•	•
Two adjustable and revolving screed control panels	•	•
Battery master switch	•	•
Electric switch cabinet	•	•
MATRIS	•	•
Structure		
All-weather roof of GRP (glass-fibre reinforced plastic)	•	•
Two seats, laterally extendable	•	•
Anti-vandalism kit	•	•
Near field mirrors at weather roof	•	•
Volvo Green Key	•	•
Screed		
Split towing arms	•	•
Screed lock	•	•
Lights		
Operator's platform lighting	•	•
Home light function	•	•
Environmental		
Sound insulation	•	•

OPTIONAL EQUIPMENT

	P6820D ABG	P7820D ABG
Material Management		
Smart Dock	•	•
Soft Dock	•	•
Heavy push rollers	•	—
Individual operating hopper wings	•	•
Hydraulically operated front apron	•	•
Auger quick lock system	•	•
Heavy duty auger	•	—
Protective half shells for auger shaft	•	•
Auger extensions and additional auger bearings	•	•
Heavy duty conveyor cover	•	•
Reversible conveyor	•	•
Central lubrication	•	•
Electrics and electronics		
Four 230V power sockets	•	•
Lateral emergency stop	•	•
High ambient temperature fan	•	•
CareTrack - GSM installation	•	•
CareTrack - Satellite installation	•	•
Pave Assist (Volvo Co-Pilot system)	•	•
Volvo Smart View camera system	•	•
Levelling equipment	•	•
Transport case for EPM control panels	•	•
Structure		
Deluxe seats with heating	•	•
Front windscreen	•	•
Tarpaulin side curtains for weather roof	•	•
Custom colours	•	•
Electrohydraulic powered weather roof	•	•
Front ballast weight	•	•
Screed		
Screed spacer blocks	•	•
Screed assist	•	•
Screed anti-climbing lock	•	•
Screed load device	•	•
Screed tensioning device	•	•
Hydraulic height adjustment of extendable screed	•	•
Hydraulic crown adjustment VB screeds	•	•
Special profiles VB79, VB89	•	•
Hydraulically adjustable Power-Float screed end gates	•	•
Heatable screed end gate	•	•
Foldable screed walkway	•	•
Lights		
Warning beacons LED	•	•
Warning beacons Halogen	•	•
Two balloon lights LED	•	•
Six worklights LED at weather roof	•	•
Six worklights Halogen at weather roof	•	•
Four additional worklights LED at weather roof	•	•
Four additional worklights Halogen at weather roof	•	•
Two additional worklights LED at rear frame	•	•
Two additional worklights Halogen at rear frame	•	•
Two additional auger worklights LED at rear frame	•	•
Two additional auger worklights Halogen at rear frame	•	•
Portable worklight LED with magnetic base	•	•
Portable worklight Halogen with magnetic base	•	•
Environmental		
Extractor for bituminous fumes	•	•
Emulsion spraying system	•	•
High performance spray cleaning unit	•	•
Biodegradable hydraulic oil	•	•

SELECTION OF VOLVO OPTIONAL EQUIPMENT

Electro hydraulic weather roof



Levelling equipment



Hydraulic end gates



Fumes extractor



Smart Dock



Front windscreen and weather protection



Not all products are available in all markets. Under our policy of continuous improvement, we reserve the right to change specifications and design without prior notice. The illustrations do not necessarily show the standard version of the machine.