

PERFORMANCE DATA

PAVER (TIER 4f)

BF 300 C-2



Greatest durability



Shorter set-up times



Exemplary efficiency

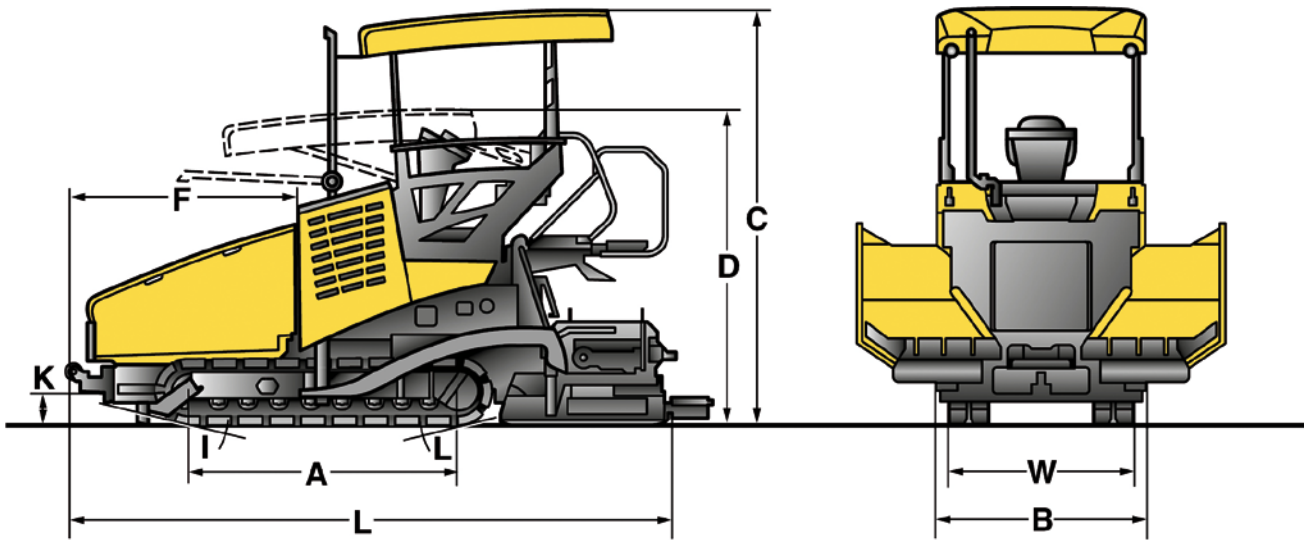

Dimensions in mm

| | A | B | C | D | G | N |
|---------------------------|----------|----------|----------|----------|----------|----------|
| BF 300 C-2 S 340-2 | 5050 | 3080 | 3270 | 3050 | 2275 | 1192 |



Hydraulic front gate – for a clean material flow.



Impact-free docking – dampened bumper.



Save up to 17 % fuel – demand-driven hydraulics – with BOMAG ECOMODE.



Heats up nearly 60 % quicker – unique MAGMALIFE heating system.

Technische Daten

Weight CECE

With S340-2 V screed / S340-2 TV screed kg

Dimensions

Transport length mm

Transport width mm

Transport height mm

Travel characteristics

Travel speed km/h

Working speed m/min⁻¹

Drive

Engine manufacturer

Type

Emission stage

Cooling

Number of cylinders / Displacement..... cm³

Rated power..... kW / HP

Crawler assembly

Total length..... mm

Width mm

Hopper

Capacity m³

Width (wings open)..... mm

Width (wings closed)..... mm

Length mm

Filling height (middle) mm

Conveyor

Number.....

Rotary speed..... U/min

Individual control

Reversing operation

Auger

Number..... mm

Auger diameter..... mm

Rotary speed..... U/min

Reversing operation

Screed

Basic width retracted mm

Basic width extended..... mm

Min. width with reduction skids mm

Mat thickness..... mm

Screed plate depth..... mm

Screed plate thickness..... mm

Heating

Crown %

Tmaper frequency Hz

Vibration frequency Hz

Basic weight..... kg

Max. working width..... mm

Filling capacities

Fuel..... l

Hydraulic oil..... l

BOMAG BF 300 C-2

8780 / 9000

5050

1880

3270

0-5

0-20 variable

Kubota

V3307-CR-T-EU4

Stage III b / TIER 4f

liquid

4 / 3331

54,6 / 75

2273

260

4,8

3080

2270

1800

515

2

33

Standard

yes

2

280

117

Standard

S340-2

1700

3400

700

250

330

12

electric

-2,5 ... +4,5

0-29

20-58

1500 / 1720

5000

95

80

Standard Equipment

Operator compartment

- SIDEVIEW
- Driver's seat: with swivel and side-shift
- Dashboard protection
- Hydraulic hinged roof
- Digital display for machine Management

Tractor

- ECOMODE
- Separate control of hopper wings
- Hydraulic, height adjustable auger
- Track scraper
- 2 proportionally controlled and reversible wear-resistant cast augers; screw blades separately replaceable
- 2 independent and reversible scraper belts;
high-wear resistant plates
- Rubber track pads

Screed

- L.C.S. Screed relief and traction increase system
- Screed temperature control
- MAGMALIFE Aluminium heating plates
- MAGMALIFE Automatic screed heating
- Mechanical screed lock
- Crown adjustment
- Side control of auger/scraper belts

Other

- Tools
- 8 work lights
- Three phase Generator
- Socket 2 x 240 volt

Optional Equipment

Operator compartment

- Weather protection for platform
- Seat warmer
- Asphalt steam extraction

Tractor

- Central lubrication system
- Optional paint finish
- Biologically degradable hydraulic oil
- Hydraulic hopper front flap
- Spring dampened push rollers

Screed

- Hydraulic crown adjustment
- Hinged side plates
- Heated side plates
- L.C.S. half-sided
- S 340-2 extensions:
350 mm
500 mm
- Reduction shoes

Levelling systems

- Height and cross-slope sensing by means of ultrasonic or mechanical sensors

Other

- Fleetmanagement BOMAG TELEMATIC
- Moon-light balloon
- LED working lights



PRE 891 17 010

100317 Sa02

BOMAG
Hellerwald
D-56154 Boppard
Postfach 5162
D-56149 Boppard
Tel. (0)6742 - 1000
Fax (0)6742 - 3090

